



PERFORMER AMC INTAKE MANIFOLDS
For 1970 & Later 290-401 c.i.d. AMC V8
Part #2131 & 3731
INSTALLATION INSTRUCTIONS

IMPORTANT NOTE: Proper installation is the responsibility of the installer. Improper installation will void your warranty and may result in poor performance and engine or vehicle damage.

DESCRIPTION: The Edelbrock Performer AMC intake manifolds have been designed for 1970 & later, 290-304-343-360-390-401 c.i.d. AMC V8 engines. Performer manifolds offer performance increases in the idle-5500 RPM range. Manifolds will not accept factory Motorcraft spread-bore carburetors.

• **KIT CONTENTS:**

- 6 #8 x 3/8" Drive Screw
- 1 10-32 x 1/2" Hex Cap Screw
- 1 1/4" x 1/8" Sleeve
- 1 1/4" Star Washer
- 1 1/4" Shank, 3/16" Hole Shoulder Stud
- 1 1/16" x 1/2" Cotter Pin

• **EGR SYSTEMS:**

#2131 Only - This manifold will not accept stock EGR (exhaust gas recirculation) equipment. EGR systems are used on most 1972 and later model vehicles. Check local laws for requirements. This manifold is a stock replacement/street legal part for 1970-1972, 360-401 c.i.d. V8s (except factory EGR) when used with the OEM 4bbl carburetor only.

#3731 Only - Edelbrock EGR-equipped Performer manifolds are intended as a direct functionally identical replacement for their OEM counterparts. All exhaust emissions or emissions-related stock components are intended to be retained and functional. Check local laws for requirements.

• **CARBURETOR RECOMMENDATIONS:** See our catalog for details regarding parts required for installation.

CARBURETOR	CHOKE TYPE	PARTS REQUIRED FOR INSTALLATION
OEM 4BBL (Non-EGR)	Electric	#8034 AMC Throttle Adapter ('79 and later); #2732 Carburetor Plate
Performer Series #1403 (500 CFM)	Electric	#8034 AMC Throttle Adapter ('79 and later); #2732 Carburetor Plate
Performer Series #1404 (500 CFM)	Manual	#8034 AMC Throttle Adapter ('79 and later); #2732 Carburetor Plate
Performer Series #1405 (600 CFM)	Manual	#8034 AMC Throttle Adapter ('79 and later); #2732 Carburetor Plate
Performer Series #1406 (600 CFM)	Electric	#8034 AMC Throttle Adapter ('79 and later); #2732 Carburetor Plate
Thunder Series #1805 (650 CFM)	Manual	#8034 AMC Throttle Adapter ('79 and later); #2732 Carburetor Plate
Thunder Series #1806 (650 CFM)	Electric	#8034 AMC Throttle Adapter ('79 and later); #2732 Carburetor Plate
Thunder Series #1825 (650 CFM)	Manual	#8034 AMC Throttle Adapter ('79 and later); #2732 Carburetor Plate
Thunder Series #1826 (650 CFM)	Electric	#8034 AMC Throttle Adapter ('79 and later); #2732 Carburetor Plate

- GASKETS:** Do not use competition-style intake gaskets for this street manifold. Due to material deterioration over time, internal leakage of vacuum, oil, and coolant may occur. **NOTE: YOU MUST USE a factory metal valley tray gasket along with the Edelbrock gaskets listed below. If your stock valley tray is in good condition, it may be re-used.**

INTAKE MANIFOLD	REFERENCE	RECOMMENDED GASKET
2131, 3731	(None)	Edelbrock #7213; Port: 1.13" x 2.21", .030" Thickness

INSTALLATION PROCEDURE

- LIFTER VALLEY HEAT SHIELD:**

- Remove the tin lifter valley heat shield from the bottom of the stock intake manifold and reinstall it on the new intake manifold with the supplied #8 x 3/8" drive screws (**See Figure 1**). **THIS IS VERY IMPORTANT! THE LIFTER VALLEY HEAT SHIELD PREVENTS OIL FROM BEING DRAWN THROUGH THE PCV VALVE!**

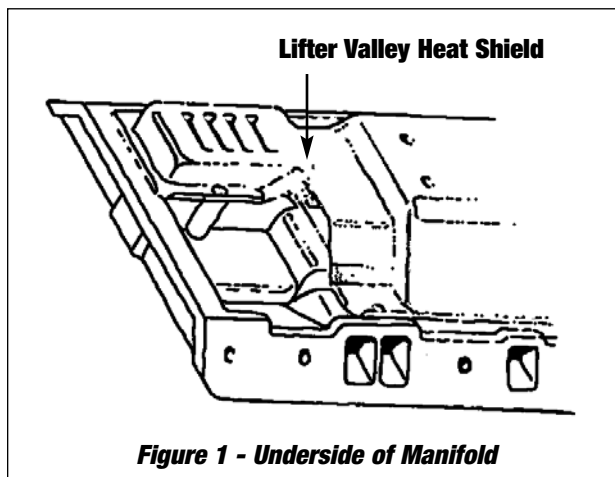

- INSTALLATION:**

- Use only recommended intake gaskets set when installing this intake manifold.
- Fully clean the cylinder head intake flanges and the engine block end seal surfaces.
- We advise eliminating the end seals. Use RTV silicone gasket sealant instead. With NO SEALER applied, place gaskets in position, and position manifold on engine. Measure and record end seal clearance. Remove manifold and gaskets.
- Apply Edelbrock Gasgacinch sealant P/N 9300 to both cylinder head flanges and to the cylinder head side of the gaskets, allow to air dry, and attach the intake gaskets to the cylinder head.
- Due to restricted amount of metal separating this manifold's water inlet ports (left and right side port flange) and front/rear bolt holes, very little gasket purchase area exists. For a complete seal, lay a 1/4" bead of RTV silicone gasket sealant around water ports, then place the factory metal valley tray into position. Also, on the valley tray, apply a thin film of RTV around each water and intake port opening and along the bottom of the tray's intake flanges where the intake manifold will meet the tray. This procedure ensures a good seal.
- Apply a bead of sealant of the appropriate thickness (as measured earlier) across the block end seal surface, overlapping the intake gasket at the corners. This procedure eliminates end seal slippage and deterioration. Set manifold on engine.
- Coat manifold bolt threads with RTV. Torque all of the manifold bolts in two steps by the sequence shown in **Figure 2** to 25 ft/lbs.

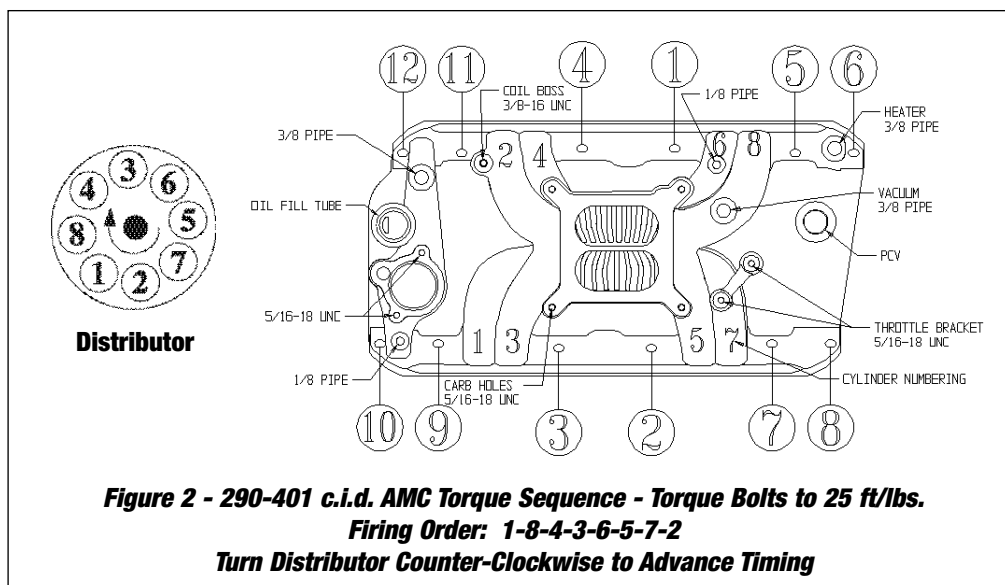

Figure 2 - 290-401 c.i.d. AMC Torque Sequence - Torque Bolts to 25 ft/lbs.

Firing Order: 1-8-4-3-6-5-7-2

Turn Distributor Counter-Clockwise to Advance Timing

- **THROTTLE & ACCESSORY BRACKETS:** Throttle and kickdown brackets on some vehicles may require modification to fit.

1. When using an Edelbrock Performer Series or Thunder Series carburetor, Square-Bore Adapter #2732 is required (**See Figure 3**).
2. Some vehicles with 4-bbl carburetors will require a throttle bracket extension plate to move the throttle bracket forward (**See Figures 4A and 4B for bracket assembly**). This part is available as Edelbrock #8034.

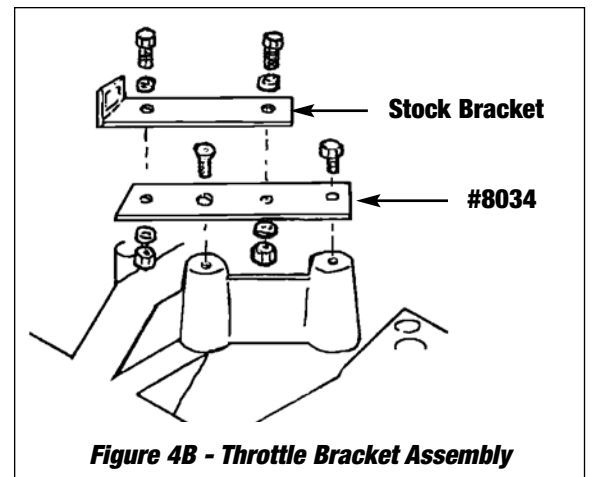
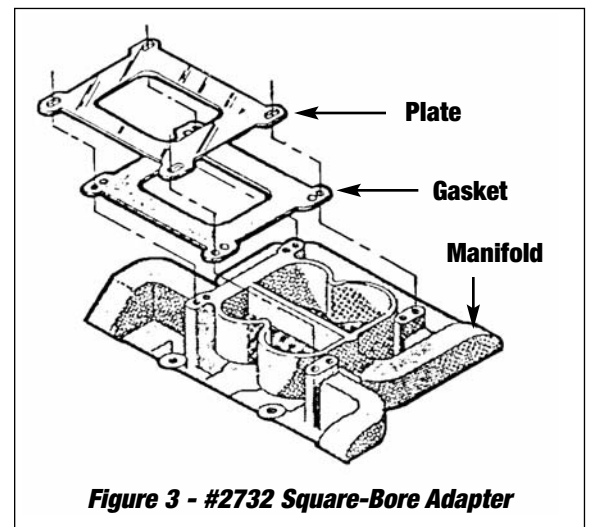
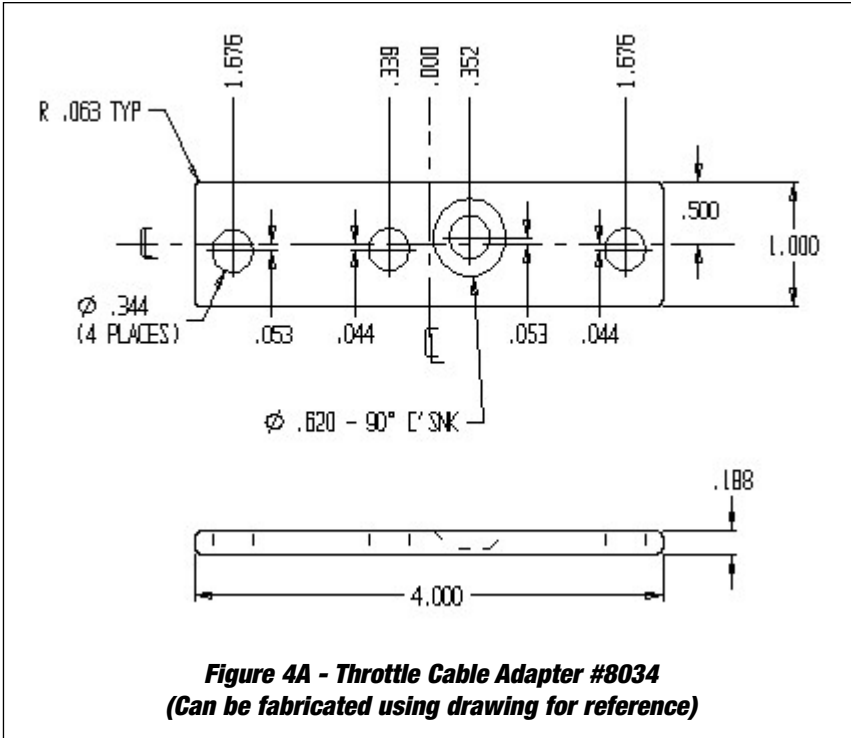

3. On vehicles equipped with an automatic transmission, a kick-down stud is required at the lower carburetor lever to operate the transmission kick down rod. This stud is supplied with each manifold and will bolt directly to Edelbrock Performer Series and Thunder Series carburetors (**See Figure 5**).

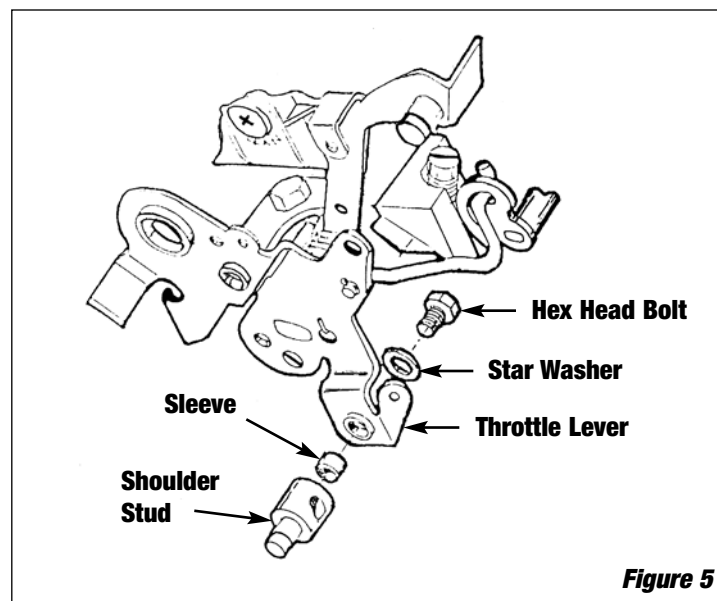

- **PCV VALVE:** Some engines use a PCV valve that is clamped to a hose between the carburetor and manifold. The stock AMC manifold has a 3/8" NPT pipe port at the manifold rather than a hole to accept a rubber grommet which the Edelbrock manifold uses. To re-install the PCV valve to our manifold, you may purchase a grommet from your local NAPA dealer, (#630-1411) and 10" of 3/8" vacuum hose (**See Figure 6**).

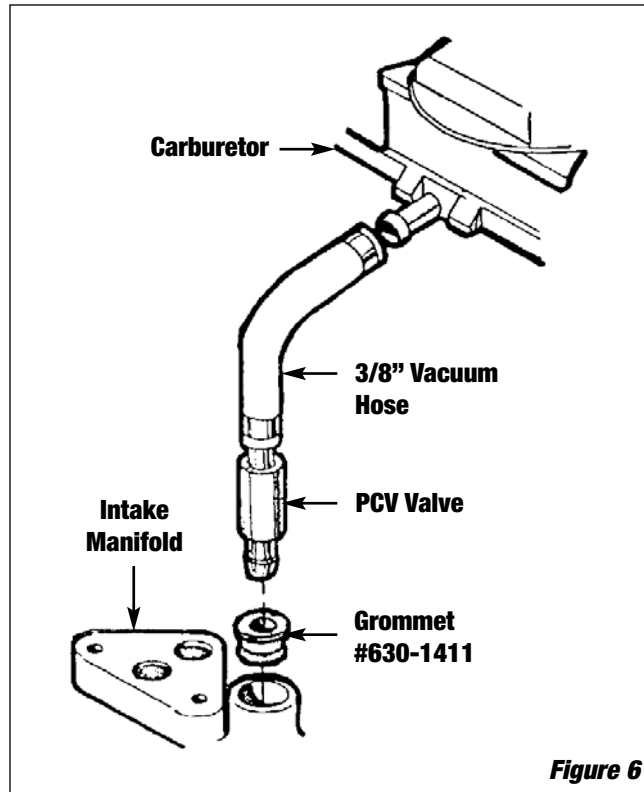

- **PREP AND TUNING FOR POWER:**

NOTE: Please refer to Edelbrock Performer Series Carburetor Owner's Manual for detailed tuning procedures.

1. Due to design, the fuel/air mixture and cylinder charging are very efficient with Performer manifolds. Generally speaking, the stock jetting for the OEM and recommended aftermarket carburetors will not need changing. Specific applications may show an increase in performance through further tuning.
 2. Aftermarket distributor curve kits may be used with this intake manifold.
 3. Use modified or high performance cylinder heads such as our Performer RPM AMC.
 4. Installation of aftermarket headers, camshafts or both may lean carburetor calibration. Should this occur, recalibrate with a richer jet.
- **CAMSHAFT AND HEADERS:** Performer manifolds are compatible with aftermarket camshafts and headers. Header primary tube diameter should be 1-5/8", depending on the specific engine combination. Edelbrock has developed a camshaft for use with this intake manifold; Performer-Plus #2132. Please check the catalog or website for rpm and application guidelines.

