





Installation and Operation Instructions EW4010 Snow Plow Worklights Kit

IMPORTANT! Read all instructions before installing and using. Installer: This manual must be delivered to the end user.

 **WARNING!**
Failure to install or use this product according to manufacturer's recommendations may result in property damage, serious bodily/personal injury, and/or death to you and those you are seeking to protect! Check wattage before installing light to avoid possible equipment damage.

 **Do not install and/or operate this safety product unless you have read and understand the safety information contained in this manual.**

1. Proper installation combined with operator training in the use, care, and maintenance of emergency safety devices are essential to ensure the safety of you and those you are seeking to protect.
2. Exercise caution when working with live electrical connections.
3. This product must be properly grounded. Inadequate grounding and/or shorting of electrical connections can cause high current arcing, which can cause personal injury and/or severe vehicle damage, including fire.
4. Proper placement and installation are vital to the performance of this safety device. Install this product so that output performance of the system is maximized and the controls are placed within convenient reach of the operator so that s/he can operate the system without losing eye contact with the roadway.
5. Do not install this product or route any wires in the deployment area of an air bag. Equipment mounted or located in an air bag deployment area may reduce the effectiveness of the air bag or become a projectile that could cause serious personal injury or death. Refer to the vehicle owner's manual for the air bag deployment area. It is the responsibility of the user/operator to determine a suitable mounting location ensuring the safety of all passengers inside the vehicle particularly avoiding areas of potential head impact.
6. It is the responsibility of the vehicle operator to ensure during use that all features of this product work correctly. In use, the vehicle operator should ensure the projection of the safety signal is not blocked by vehicle components (i.e., open trunks or compartment doors), people, vehicles or other obstructions.
7. The use of this or any other safety device does not ensure all drivers can or will observe or react to a warning signal. Never take the right-of-way for granted. It is your responsibility to be sure you can proceed safely before entering an intersection, driving against traffic, responding at a high rate of speed, or walking on or around traffic lanes.
8. This equipment is intended for use by authorized personnel only. The user is responsible for understanding and obeying all laws regarding warning signal devices. Therefore, the user should check all applicable city, state, and federal laws and regulations. The manufacturer assumes no liability for any loss resulting from the use of this safety device.

Note:
The product gets very hot to the touch after operating constantly for several hours.

Specifications:

Overall dimensions: 9.0" x 5.9" x 3.3"

Weight: 5.1 lbs.

Input Voltage: 12-24VDC

Temp. Range: -40° to 65°C
-40° to 150°F

Power Consumption per light: 50W Max
Power Consumption for low beams w/ lens heater: 52W Max
Power Consumption for high beams w/ lens heater: 70W Max

Current Draw at 13.8VDC per light: 7.2A Max
High Beams: 2.9A Max
Low Beams: 1.5A Max
Parking Light: 0.1A Max
Indicator Light: 1.5 A Max
Low Beams with lens heater: 4.1 A Max
High Beams with lens heater: 5.5A Max

Installation Instructions:

Carefully examine the unit for damage before installation. If damage is found, contact the transit company or ECCO. Do not use broken or damaged parts.

Prior to mounting, consideration should be given to cable location. The mounting location should be chosen such that there is maximum visibility to the oncoming traffic.

Indicator Installation:

Each kit includes 1 indicator light per flood light which can be installed on top or either side.

To assemble the indicator on the flood light, start by removing the M3 screws and indicator port cover. Connect the indicator wires to the flood light and cover the connection in dielectric grease to reduce exposure to the elements.

Install the indicator as shown in Figure 1 and secure in place with the two M4 screws included using a 3mm hex key.

NOTE: The amber indicator functions only as a turn signal.

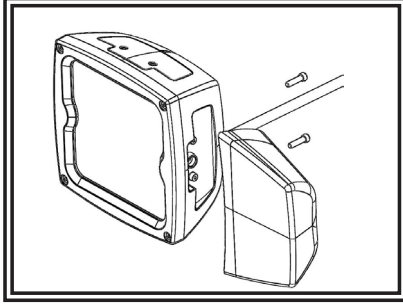

FIGURE 1

Bracket Mounting:

1. Select a mounting location for the unit on a flat surface and drill a 15/32" hole.
2. Secure the light head with the supplied hardware by using the M5 screws and lock washers as shown in Figures 2 or 3.

Aiming Instructions:

Installer is responsible for ensuring the snowplow lights are aimed properly such that beams comply with current highway regulations. Beams should project the same distance ahead as compliant OEM headlights.

Wiring Instructions:

Important! Disable power before wiring the product.

The wiring configuration is as shown in Figure 4. All wiring should be a minimum of 16 AWG. The positive line must have a slow blow 25 or 30 amp fuse. Routing the ground wire directly back to negative battery terminal is recommended. Pack dielectric grease, such as Dow Corning 4, around each electric connection exposed to moisture or the ambient environment.

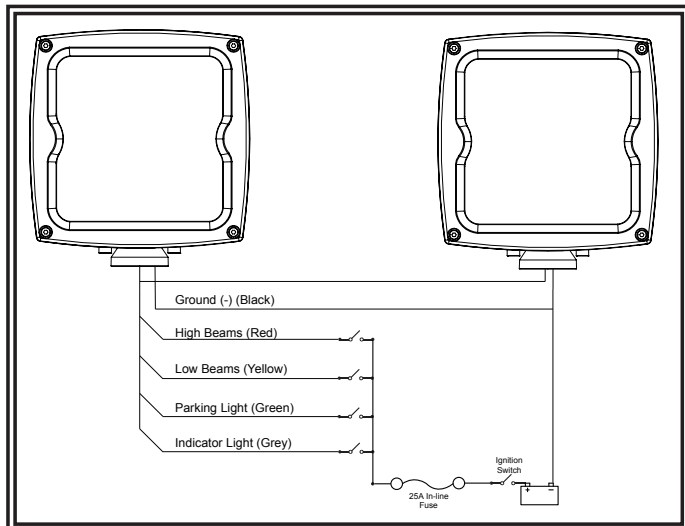

FIGURE 4

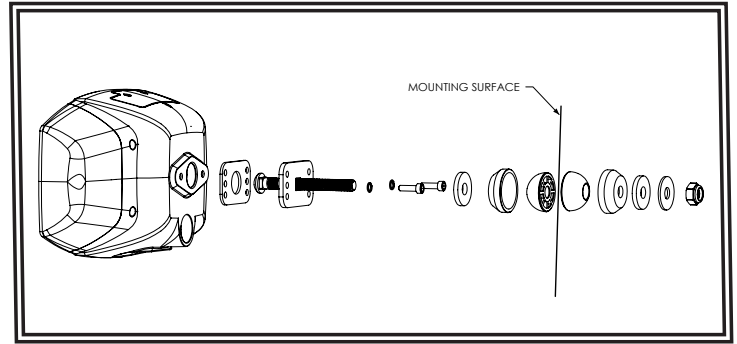

FIGURE 2

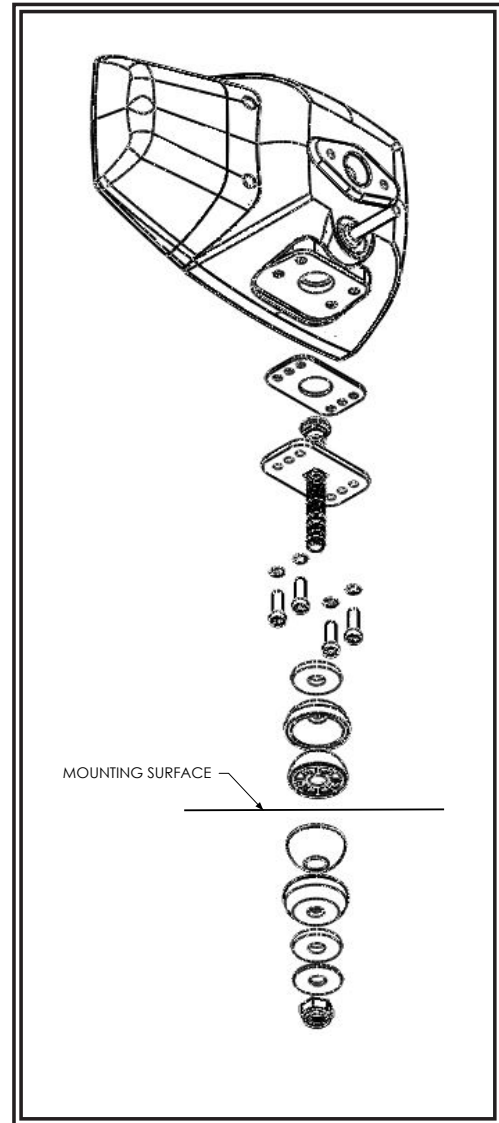

FIGURE 3