



# ECCO®

## Installation and Operation Instructions EW3420 Combination Lightbar



### WARNING!

Failure to install or use this product according to manufacturer's recommendations may result in property damage, serious injury, and/or death to those you are seeking to protect!



Do not install and/or operate this safety product unless you have read and understand the safety information contained

1. Proper installation combined with operator training in the use, care, and maintenance of emergency warning devices are essential to ensure the safety of you and those you are seeking to protect.
2. Exercise caution when working with live electrical connections.
3. This product must be properly grounded. Inadequate grounding and/or shorting of electrical connections can cause high current arcing, which can cause personal injury and/or severe vehicle damage, including fire.
4. Proper placement and installation are vital to the performance of this warning device. Install this product so that output performance of the system is maximized and the controls are placed within convenient reach of the operator so that s/he can operate the system without losing eye contact with the roadway.
5. Do not install this product or route any wires in the deployment area of an air bag. Equipment mounted or located in an air bag deployment area may reduce the effectiveness of the air bag or become a projectile that could cause serious personal injury or death. Refer to the vehicle owner's manual for the air bag deployment area. It is the responsibility of the user/operator to determine a suitable mounting location ensuring the safety of all passengers inside the vehicle particularly avoiding areas of potential head impact.
6. It is the responsibility of the vehicle operator to ensure during use that all features of this product work correctly. In use, the vehicle operator should ensure the projection of the warning signal is not blocked by vehicle components (i.e., open trunks or compartment doors), people, vehicles or other obstructions.
7. The use of this or any other warning device does not ensure all drivers can or will observe or react to a warning signal. Never take the right-of-way for granted. It is your responsibility to be sure you can proceed safely before entering an intersection, driving against traffic, responding at a high rate of speed, or walking on or around traffic lanes.
8. This equipment is intended for use by authorized personnel only. The user is responsible for understanding and obeying all laws regarding warning signal devices. Therefore, the user should check all applicable city, state, and federal laws and regulations. The manufacturer assumes no liability for any loss resulting from the use of this warning device.

### Specifications:

Size:	51.1"L X 2.3"W X 3.1"H
Weight:	12.2 lbs.
Input Voltage:	12-24 VDC Systems
Max. Input Current:	13.5 Amps at 12.8 VDC 6.24 Amps at 25.6 VDC
Max Power Consumption:	172.8 Watts at 12.8 VDC 159.7 Watts at 25.6 VDC
Flash Rate:	See Flash Pattern Chart
Temperature Range:	-40°F to 158°F

### Installation & Mounting:

Carefully examine the unit for damage before installation. If damage is found, contact the transit company or ECCO. Do not use broken or damaged parts.

Prior to mounting, consideration should be given to cable location. The mounting location should be chosen such that there is maximum visibility to the oncoming traffic.

#### Rear Mounting:

1. Insert a hex head bolt through each rear mount bracket and loosely secure the brackets to the rear of the lightbar with the button head bolts as shown in FIGURE 1.
2. Position the lightbar in the desired mounting location on the front of the vehicle with the cable exit to the passenger side. Slide the rear mount brackets into place ensuring there is at least 18" between them. Mark and drill two 1/4" holes and secure the rear mount brackets in place on the vehicle using the included nylon insert nuts.
3. With the vehicle on a level surface, place the included cardboard cutout over the lightbar and angle the lightbar on the mounting brackets until the top surface of the cardboard is level as shown in FIGURE 2. This ensures the light output angle of the safety director and worklight LEDs is optimized.
4. Tighten the button head screw in each rear mounting bracket to secure the lightbar at that angle.

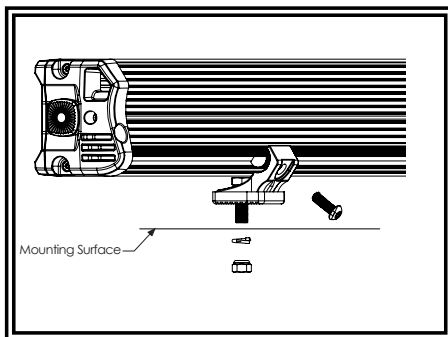

Figure 1

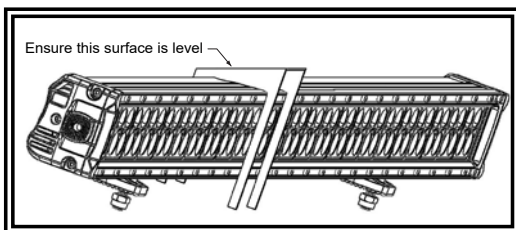

Figure 2

## End Mounting:

- Loosely secure the end brackets to the lightbar with the head bolts as shown in FIGURE 3.
- Position the lightbar in the desired mounting location on the front of the vehicle with the cable exit to the passenger side. Mark and drill two 1/4" holes and secure the brackets in place on the vehicle using the included hardware.
- With the vehicle on a level surface, place the included cardboard cutout over the lightbar and angle the lightbar on the mounting brackets until the top surface of the cardboard is level as shown in FIGURE 2. This ensures the light angle of the safety director and worklight LEDs is optimized.
- Tighten the button head screw in each end bracket to secure the lightbar at that angle.

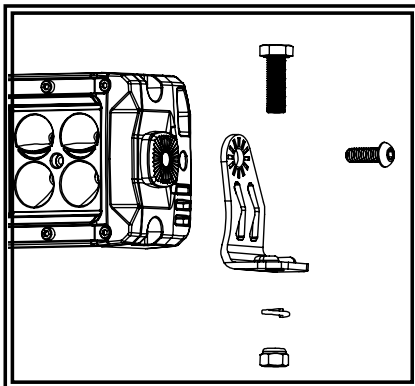

Figure 3

## Wiring Instructions:

### Notes:

- Larger wires and tight connections will provide longer service life for components. For high current wires it is highly recommended that terminal blocks or soldered connections be used with shrink tubing to protect the connections. Do not use insulation displacement connectors (e.g., 3M Scotchlock type connectors). Route wiring using grommets and sealant when passing through compartment walls. Minimize the number of splices to reduce voltage drop.
- High ambient temperatures (e.g., under-hood) will significantly reduce the current carrying capacity of wires, fuses, and circuit breakers. All wiring should conform to the minimum wire size and other recommendations of the manufacturer and be protected from moving parts and hot surfaces. Looms, grommets, cable ties, and similar installation hardware should be used to anchor and protect all wiring.
- Fuses or circuit breakers should be located as close to the power takeoff points as possible and properly sized to protect the wiring and devices.
- Particular attention should be paid to the location and method of making electrical connections and splices to protect these points from corrosion and loss of conductivity.
- Ground termination should only be made to substantial chassis components, preferably, directly to the vehicle battery.
- Circuit breakers are very sensitive to high temperatures and will "false trip" when mounted in hot environments or operated close to their capacity.

**Important!** Disable power before wiring the lightbar.

The wiring for this configuration is as shown in FIGURE 4. All wiring should be a minimum of 14 AWG. The positive line must have a slow blow 20 amp fuse. Routing the ground wire directly back to negative battery terminal is recommended. Pack dielectric grease, such as Dow Corning 4, around each electric connection exposed to moisture or the ambient environment.

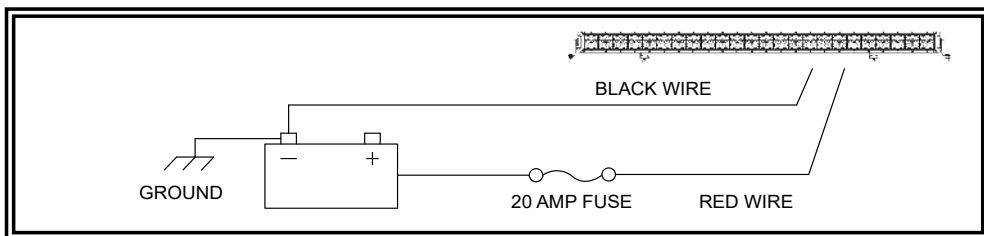

Figure 4

## Control Pad Operation:

Press the left power button to power the amber safety director LEDs on and off. The left arrow, mode and right arrow buttons control the left, center out/wig wag and right patterns respectively as called out in the flash pattern chart. The keypad LEDs will mimic the lightbar's safety director LEDs.

The ALT button enables the white flood LEDs.

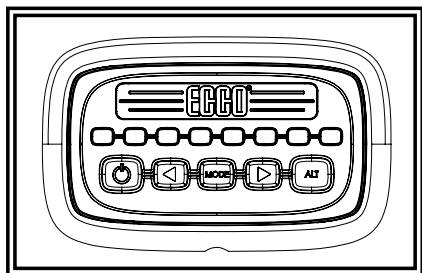

Figure 5

Flash Pattern Summary			
Control Pad Button	No.	Description	FPM
◀	1	Left Chase	27
	2	Left Fill	27
MODE	1	Center Out Chase	50
	2	Center Out Fill	50
	3	Wig Wag	150
	4	Single Alternating	150
	5	Triple Alternating	60
▶	6	Amber Steady	N/A
	1	Right Chase	27
	2	Right Fill	27

**Replacement Parts and Accessories:**

<b>Description</b>	<b>Part Number</b>
Control Pad Replacement	EW3420CB
Mounting Kit Replacement	ER3420MK
Control Pad Extension Cable Accessory	EZ3420-CBL