

**WARNING!**

Failure to install or use this product according to manufacturer's recommendations may result in property damage, serious injury, and/or death to those you are seeking to protect!



**Do not install and/or operate this safety product unless you have read and understood the safety information contained in this manual.**

- Proper installation combined with operator training in the use, care, and maintenance of emergency warning devices are essential to ensure the safety of emergency personnel and the public.
- Emergency warning devices often require high electrical voltages and/or currents. Exercise caution when working with live electrical connections. This product must be properly grounded. Inadequate grounding and/or shorting of electrical connections can cause high current arcing, which can cause personal injury and/or severe vehicle damage, including fire.
- Proper placement and installation is vital to the performance of this warning device. Install this product so that output performance of the system is maximized and the controls are placed within convenient reach of the operator so that they can operate the system without losing eye contact with the roadway.
- Do not install this product or route any wires in the deployment area of an air bag. Equipment mounted or located in an air bag deployment area may reduce the effectiveness of the air bag or become a projectile that could cause serious personal injury or death. Refer to the vehicle owner's manual for the air bag deployment area. It is the responsibility of the user/operator to determine a suitable mounting location ensuring the safety of all passengers inside the vehicle particularly avoiding areas of potential head impact.
- It is the responsibility of the vehicle operator to ensure daily that all features of this product work correctly. In use, the vehicle operator should ensure the projection of the warning signal is not blocked by vehicle components (i.e., open trunks or compartment doors), people, vehicles or other obstructions.
- The use of this or any other warning device does not ensure all drivers can or will observe or react to an emergency warning signal. Never take the right-of-way for granted. It is the vehicle operator's responsibility to be sure they can proceed safely before entering an intersection, drive against traffic, respond at a high rate of speed, or walk on or around traffic lanes.
- This equipment is intended for use by authorized personnel only. The user is responsible for understanding and obeying all laws regarding emergency warning devices. Therefore, the user should check all applicable city, state, and federal laws and regulations. The manufacturer assumes no liability for any loss resulting from the use of this warning device.

**CONTENTS:**

1	Light Head
2	Screws
1	Installation Guide
1	Mounting Gasket
1	Bezel
1	Alcohol Wipe

**Important!** This unit is a safety device and it must be connected to its own separate, fused power point to assure its continued operation should any other electrical accessory fail.

**Caution:** When drilling into any vehicle surface, make sure the area is free from any electrical wires, fuel lines, vehicle upholstery, etc. that could be damaged.

**Caution:**

- light cannot be twisted or pulled
- do not bend in the lens direction
- Mounts to a surface curvature with a minimum radius of 3 inches.

**SPECIFICATIONS:**

Input Voltage	12-24VDC
Current	0.8A Max @ 12VDC 0.5A Max @ 24VDC
Physical H x W x L	3.9 in x 0.9 in x 0.4 in 9.9 cm x 2.3 cm x 1 cm
Ship Weight	0.1 lb (0.05 Kg)

Maximum flex is 120 degrees

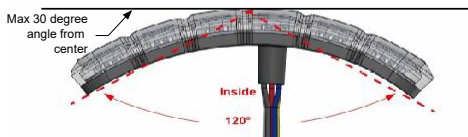

**No Pulling**  
Can not pull the wire because the PCB and components will be damaged.

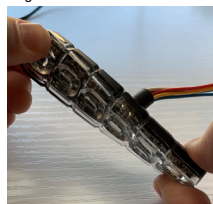

**No Twisting**  
The product can't be twisted because the PCB and components will be damaged.

## Mounting:

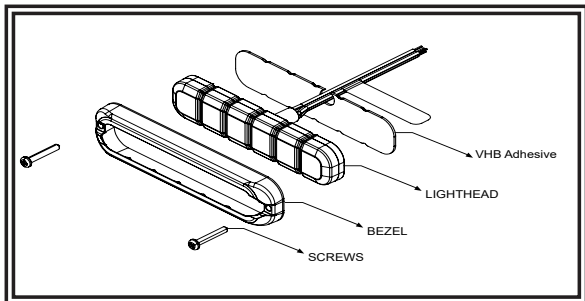

\*For extra adhesion, use 3M Tape Primer. For product & application information, go to: <https://multimedia.3m.com/mws/media/659520/3mtm-tape-primer-94.pdf>

## Wire:

RED: Positive, Colors 1 & 3 (need to add 5A fuse)  
WHITE: Positive, Colors 2 & 4 (need to add 5A fuse)  
RED & WHITE: Positive (Colors 1 & 3) & (Colors 2 & 4)  
BLACK: Negative  
BLUE: Pattern select to negative  
YELLOW: Synchronized Function  
(Up to 8 units can be Synchronized)

## Operation Environment:

Ambient Temperature: -30 to 50°C (-22° F to 122°F)

## Mounting on a curved surface:

1. Mark hole location using gasket as a template and drill hole for wire exit using 11/32 in. drill bit.
2. Wipe surface clean with alcohol wipe. Wait until dry.
3. Mount light using VHB adhesive. Peel adhesive backing and apply pressure to adhere to surface for 20 seconds. It is recommended to allow 24 hours for adhesive to fully adhere before powering on light.

\* Do not use hardware, gasket or bezel when mounting on curved surface.

\* Max surface curvature 120°.

## Mounting on flat surface:

1. Mark wire and screw locations using gasket as a template. Drill wire exit hole using 11/32 in. drill bit. Pre-drill screw holes using 3/64 in. drill bit.
2. Peel VHB backing and apply light to surface, aligning screw holes and wire exit. Apply pressure for 20 seconds. Insert screws through bezel to finish mounting lighthouse. It is recommended to allow 24 hours for adhesive to fully adhere before powering on light.

## Phase Operation:

Phase 1 (Ph1) flashes simultaneously with Ph1  
Phase 2 (Ph2) flashes simultaneously with Ph2  
Ph1 alternates with Ph2  
(Up to 8 units can be Synchronized)

## Apply BLUE TO BLACK wire:

-Less than 1 sec. for next pattern  
-Between 1-3 sec for previous pattern  
-Between 3-5 sec. for factory default  
-More than 5 sec. for last pattern

