



BEACONS | MINIBARS | LIGHTBARS | WORKLAMPS | UTILITY BARS | INTERIOR LIGHTING | BACK-UP ALARMS | CAMERA SYSTEMS

DIRECTIONALS

ED0010 SERIES Concealed Warning LED

The Hide-A-LED™ Bullet is a concealed LED warning light that features two high intensity 3-watt LEDs to deliver an exceptionally bright warning signal. Available with 3/4" or 2" shaft lengths, the Bullet is designed to allow quick and easy installation in any headlight or tail light casing. Requiring only a single 1/2" hole, the Bullet's shape overcomes the problem of difficult installation in the highly compact, double-wall design of modern vehicle light casings. In addition, the Bullet is self-adhesive and requires no mounting hardware (can also be secured with screws). The unit features 12-24 VDC operation, 16 flash patterns, the ability to synchronize with additional units, and an included 9' cable.

Models

PART NO.	TYPE	VDC	AMPS	LUMENS		
				Amber/Red	Clear	Blue
ED0010X	3/4"	12-24	0.5	200	460	100
ED0011X	2"	12-24	0.5	200	460	100

Replace X in part number with desired LED color: A = amber, B = blue, C = clear, R = red

Features and Benefits

- Two 3-watt high-intensity LEDs provide exceptional warning
- 16 flash patterns including single, double, triple, quad, deci and cycle all
- Synchronizable (simultaneous or alternating operation)
- Quick and easy 1/2" hole installation
- Self-adhesive peel-and-stick mounting (can be secured with screws)
- In-line waterproof driver module eliminates the need for a remote power supply
- Nickel-plated aluminum housing and 9' cable
- CE, R10, IP67
- Warranty: 3 years

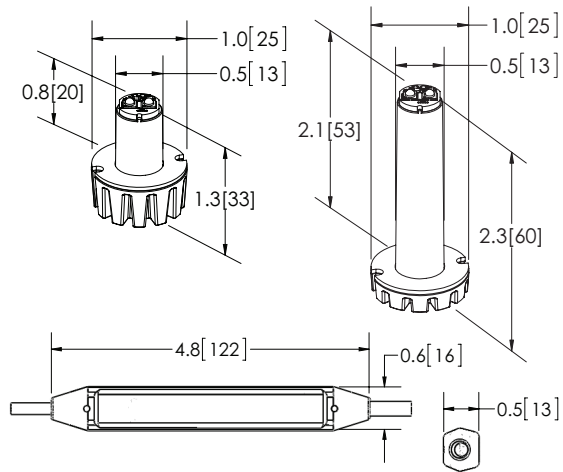

DIRECTIONALS

Flash Patterns

Flash patterns are selected by touching the blue wire momentarily to power; the LED head will cycle through the available patterns.

STANDARD PATTERNS			
#	PATTERNS	FREQUENCY	DESCRIPTION
1	Quad Flash	1.25 Hz	75 Quad FPM
2	Double Flash	1.25 Hz	75 Double FPM
3	Triple Flash	1.25 Hz	92.3 Triple FPM
4	Deciblast	1.25 Hz	85.5 Deci FPM
5	Single Flash	1.25 Hz	75 Single FPM
6	Mega Flash	1.25 Hz	114 Single FPM
7	Triple+Burst	1.25 Hz	82.5 Triple + Burst FPM
8	Steady On		Steady On

CYCLE PATTERNS			
#	PATTERNS	FREQUENCY	DESCRIPTION
9	Cycle All		Cycle through patterns 1 to 7
10	Double-Triple + Burst		2 Double, 2 Triple + Burst cycle
11	Cycle Classic		1 Double, 1 Quad, 2 Mega cycle
12	Quad-Mega		3 Quad, 4 Mega cycle
13	Single-Quad		2 Single, 2 Quad cycle
14	DeciBlast-Quad		2 DeciBlast, 2 Quad cycle
15	Single-Triple-DeciBlast		2 Single, 2 Triple, 2 DeciBlast cycle
16	Mega-Triple+Burst		1 Mega, 1 Triple+Burst cycle

Alternating/Simultaneous Flash Selection

The yellow wire on each LED head is used to determine alternating or simultaneous operation with other heads in the system that are connected using the blue wire. The yellow wire has no function when 'Steady On' flash pattern is selected.

- Connect the YELLOW wire to either POWER or GROUND
- Heads with YELLOW connected to POWER fire SIMULTANEOUSLY with other heads connected to POWER
- Heads with YELLOW connected to GROUND fire SIMULTANEOUSLY with other heads connected to GROUND
- Heads with YELLOW connected to POWER fire ALTERNATELY with other heads connected to GROUND

Note: The blue wires of all LED heads must be connected together for the alternating/simultaneous function to operate.

Wiring Diagram

The diagram below shows a typical installation of 4 HIDE-A-LEDs™ using an on/off switch. The left and right-side heads are configured to flash alternately with each other using the blue wire to connect the two with the yellow wire on one connected to ground and the yellow wire on the other connected to power.

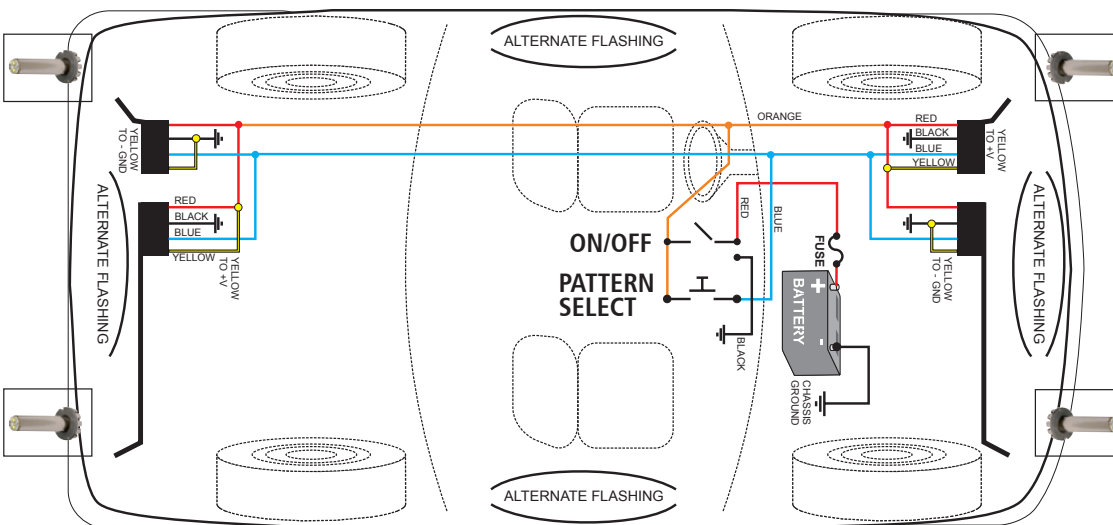

The front and rear heads are configured to flash independently of each other. In order to have the front and rear heads flash in synchronization, the blue wires from all units must be connected. The yellow wire can then be used to determine either alternate or simultaneous flash between each unit in the system by connecting to either power or ground.