

EZPANEL1

ELECTRONIC CONTROL PANEL



TECHNICAL SPECIFICATIONS

INPUT VOLTAGE +10 to 30 Volts dc
 INPUT CURRENT 25ma Max, 5ma in stanby
 ITEMS INCLUDED:
 (1) CONTROL PANEL
 (1) 14 FOOT MODULAR CABLE
 (2) #8 X 3/4" MOUNTING SCREWS

DIMENSIONS

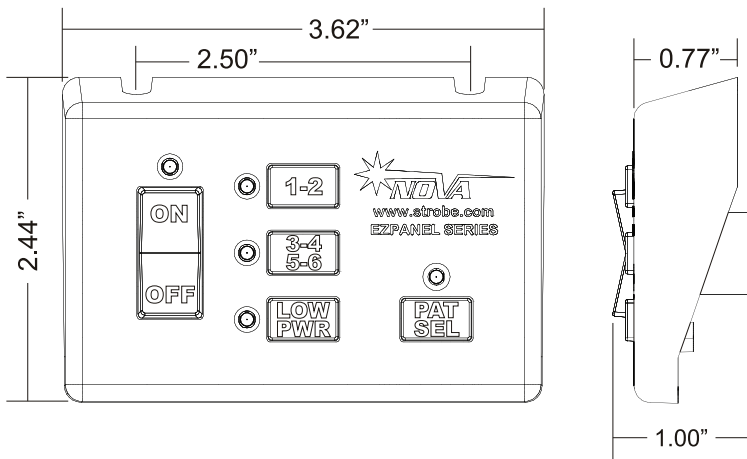

INSTALLATION

The EZPANEL1 is only for use with strobe power supplies having a connector labeled "EZ PANEL". Using the EZPANEL1 with any other power supply may damage the panel, pwer supply or both.

MOUNTING

The EXPANEL1 is mounted using the two slots at the top of the bracket. Two #8 drill point scres are included.

PANEL WIRING:

Plug either end of the included MODULAR CABLE into the back of the EZPANEL1. Plulg the other end into the power supply. The EZPANEL1 receives power through this cable. A 9/16" hole is required to route the cable through any vehicle chassis panels.

POWER SUPPLY WIRING:

Connect **ONLY** the RED and BLACK wires on the power supply wiring harness. Do not install the CONTROL connector. Remove the violet wire. Connecting any of the other control wires will interfere with the operation of the EZPANEL1.

USING THE EZPANEL1

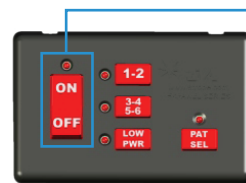

ON/OFF SWITCH:

Press the top of the switch to turn the power supply ON. The indicator LED will light. Press the bottom of the switch to turn the power supply OFF. The indicator LED will turn off.

NOTE: The state of the Outlet Selection buttons, pattern and flash pattern will be remembered when the panel is turned on/off.

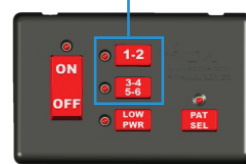

OUTLET SELECTION:

1-2 Button enables/disables power supply outlets 1 and 2.
 3-4 5-6 Button enables/disables power supply outlets 3-4 on a 4 outlet supply and outlets 3-4-5-6 on a 6 outlet supply. The LED indicators show the outlets that are enabled.

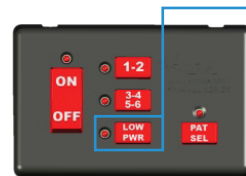

LOW POWER:

Activates the LOW POWER function on the power supply. This reduces the intensity of the strobe lights and is typically used for nighttime use. See power supply install sheet for details. The LED indicator lights when LOW POWER is enabled.



PATTERN SELECT:

Press PAT SEL to advance to the next flash pattern in the list. See power supply install sheet for the full list of flash patterns. The LED indicator gives a visual indication of the selected flash pattern and also serves as a diagnostic indicator.

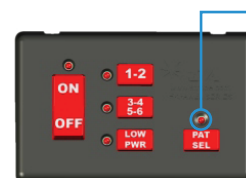

DIAGNOSTIC INDICATOR:

The LED indicator gives a real-time indication of pwer supply operation. It also indicates a short circuit condition on any of the strobe heads. See OUTPUT INDICATOR section of the power supply install sheet for troubleshooting steps.

WIRING DIAGRAM

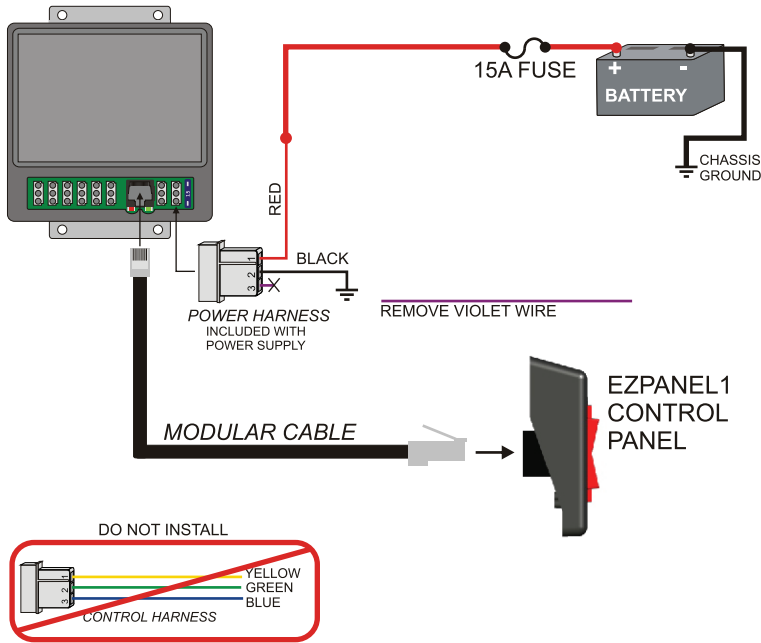

DISABLE PATTERN LED

When using one EZPANEL1 control panel with 2 or 3 power supplies, the LED indicator above the PAT SEL button will appear to flash erratically. This is because the flash patterns of two or more power supplies will not be in perfect time with each other. The LED will blink whenever any one of the strobe heads fire.

If this is distracting, or you do not wish to see the LED indicator blinking you may disable it

Press ON and LOW PWR buttons at the same time to disable the PATTERN LED.

Press ON and LOW PWR buttons at the same time again to enable the PATTERN LED.

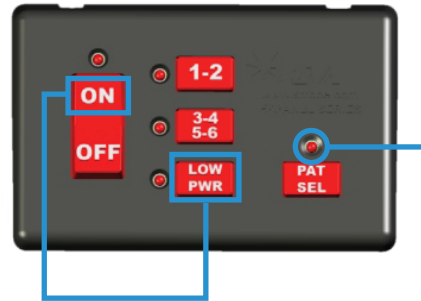

MULTIPLE POWER SUPPLIES

One EZPANEL1 can control up to a maximum of 3 power supplies using splitters and patch cables.

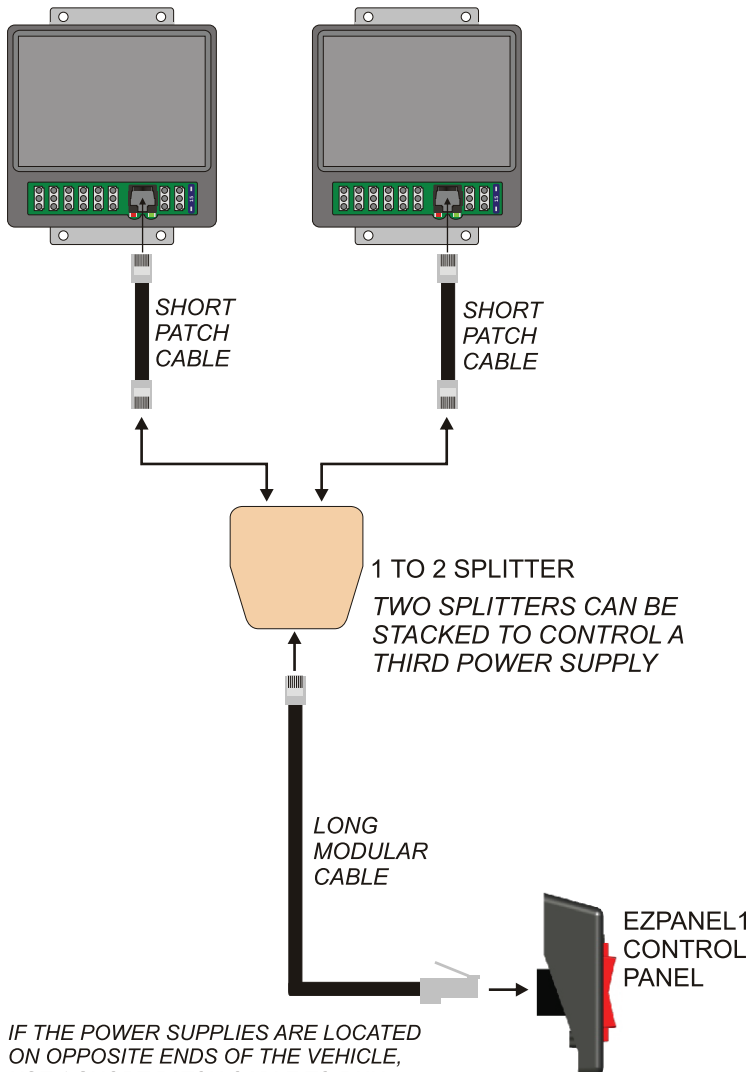

IF THE POWER SUPPLIES ARE LOCATED ON OPPOSITE ENDS OF THE VEHICLE, USE 1 SHORT PATCH CABLE TO RUN TO THE SPLITTER AND 2 LONG CABLES TO RUN TO THE POWER SUPPLIES...

ACCESSORIES

PART NUMBER	DESCRIPTION
EZPANELCBL14	14' MODULAR CABLE FOR EZPANEL SERIES SWITCH PANELS
EZSPLITTER2	SPLITTER TO ALLOW ONE PANEL TO CONTROL TWO POWER SUPPLIES