



Installation Instructions

9021 Hide-A-LEDs

The dual head (9021) Hide-A-LED™ concealed warning light offers high-intensity light output from a tiny package. Designed specifically to be installed inside vehicle head and tail lighting, each unit features 16 synchronizable flash patterns. The 9021 model includes an in-line waterproof power module and 4' cable to power supply; as well as 4' and 7' cables to two light heads. This manual provides information about installation, function, safety, maintenance, replacement parts and warranty.



IMPORTANT! Read all instructions before installing and using. Installer: This manual must be delivered to the end user.

WARNING!

Failure to install or use this product according to manufacturer's recommendations may result in property damage, serious bodily/personal injury, and/or death to you and those you are seeking to protect!



Do not install and/or operate this safety product unless you have read and understand the safety information contained in this manual.

1. Proper installation combined with operator training in the use, care, and maintenance of emergency warning devices are essential to ensure the safety of you and those you are trying to protect.
2. Exercise caution when working with live electrical connections.
3. This product must be properly grounded. Inadequate grounding and/or shorting of electrical connections can cause high current arcing, which can cause personal injury and/or severe vehicle damage, including fire.
4. Proper placement and installation are vital to the performance of this warning device. Install this product so that output performance of the system is maximized and the controls are placed within convenient reach of the operator so that s/he can operate the system without losing eye contact with the roadway.
5. It is the responsibility of the vehicle operator to ensure during use that all features of this product work correctly. In use, the vehicle operator should ensure the projection of the warning signal is not blocked by vehicle components (i.e., open trunks or compartment doors), people, vehicles, or other obstructions.
6. The use of this or any other warning device does not ensure all drivers can or will observe or react to a warning signal. Never take the right-of-way for granted. It is your responsibility to be sure you can proceed safely before entering an intersection, driving against traffic, responding at a high rate of speed, walking on or around traffic lanes.
7. This equipment is intended for use by authorized personnel only. The user is responsible for understanding and obeying all laws regarding warning signal devices. Therefore, the user should check all applicable city, state, and federal laws and regulations. The manufacturer assumes no liability for any loss resulting from the use of this warning device.

Specifications:

Input Voltage: 10 to 30 VDC
Input Current: 1A @ 12.8V, 0.45A @ 25.6V
Lumens: Amber 160+
Blue 155+
Red 123+
Clear 660+

Dimensions:

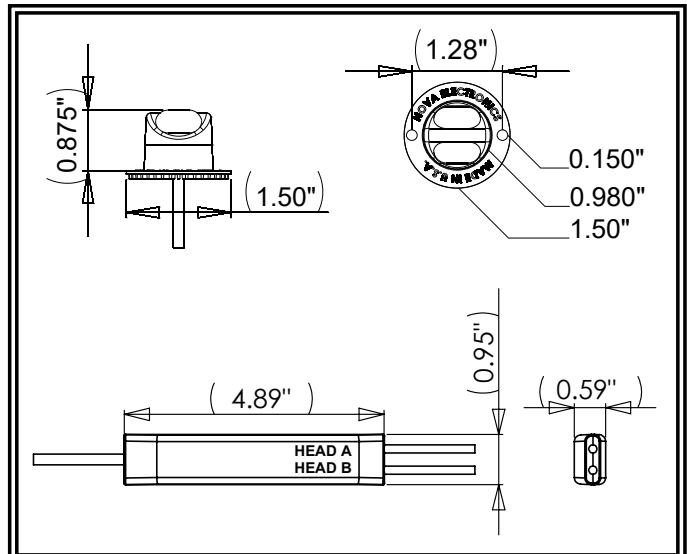

Important! This unit is a safety device, and it must be connected to its own separate, fused power point to assure its continued operation should any other electrical accessory fail.

Important! This HIDE-A-LED™ is only waterproof when mounted inside of a lens assembly.

Installation & Mounting:

Before installation, examine the LED heads for transit damage. Do not use damaged or broken parts.

Drill a 1" diameter hole in the reflector of the lens assembly. A 1" hole saw is typically used. The HIDE-A-LED™ may be used as a template to mark the location of the two screw holes. The 9021 may be mounted in either the back surface, bottom or sides of a reflector. Drill pilot holes with a 7/64" drill bit. Install the HIDE-A-LED™ into the lens assembly using the supplied gasket and screws. If the mounting surface is curved additional sealing may be necessary. Use RTV Silicone sealant if needed.

Tip: Apply RTV silicone to the screws to seal the threads.

Strap the waterproof power module to the body of the vehicle away from any high heat sources. Do not drill holes through the power module!

The heatsink will be hot after running for an extended period. DO NOT TOUCH. It will NOT melt any of the plastic parts of the lens assembly.

For dual wall reflectors: First use a 1.5" hole saw to drill through outer layer only. Then use 1" hole saw to drill through inner layer using same pilot drill hole. Install the LED head through the 1.5" hole and seal the gap with RTV silicone.

Electrical Connections:

If you wish to use the product in a wet location, then the connectors MUST BE SEALED PROPERLY:

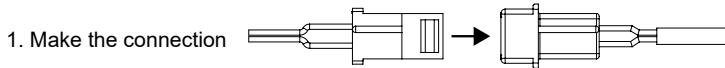

2. Seal the connectors in 3 locations

Use an RTV silicone sealant such as PERMATEX® Ultra Black

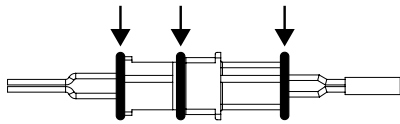

The cable on the HIDE-A-LED™ was made long enough to run across the front or the rear of a vehicle. Trim the cable shorter if needed. The wiring diagram on page 2 shows a typical install.

RED: +V

Connect to +V through an ON/OFF switch. The use of a fuse located close to the voltage source is recommended. Size the fuse according to the number of heads used in the system. 18AWG or larger wire is recommended.

BLACK: - GROUND

Connect to - GROUND vehicle chassis. 18AWG or larger wire is recommended.

BLUE: Flash pattern SYNC and SELECTION wire.

If you wish to have all the LED heads synchronize their flash timings and patterns with each other then all the BLUE wires must be connected together (64 Heads Maximum). The BLUE wire is also used to select the flash pattern. Touch the BLUE wire to +V to select the next pattern in the FLASH PATTERN LIST. The BLUE wire can also be run to a momentary push-button located on the dashboard to allow the flash pattern to be changed when desired.

Note: Do not connect the BLUE wire to - Ground. It will disrupt the flash pattern sync signal.

YELLOW: Alternating / Simultaneous selection.

The BLUE wires of all HIDE-A-LED™ heads must be connected together for the alternating /simultaneous function to work. Connect to either +V or GROUND (GND). The YELLOW wire makes the head fire AT THE SAME TIME or ALTERNATING with the other heads in the system. Heads with YELLOW connected to +V fire at the same time. Heads with YELLOW connected to GND fire at the same time. Heads with YELLOW connected to +V will ALTERNATE with heads that have YELLOW connected to GND. The YELLOW wire has no function in STEADY ON mode.

SPLIT COLOR: Split color heads will always alternate flash the two colors. The YELLOW wire will select which colors flash at the same time and which alternate.

Wiring Diagram:

Installation of a 2 HIDE-A-LED™ Deuce using pattern select switch panel (optional) on dashboard.

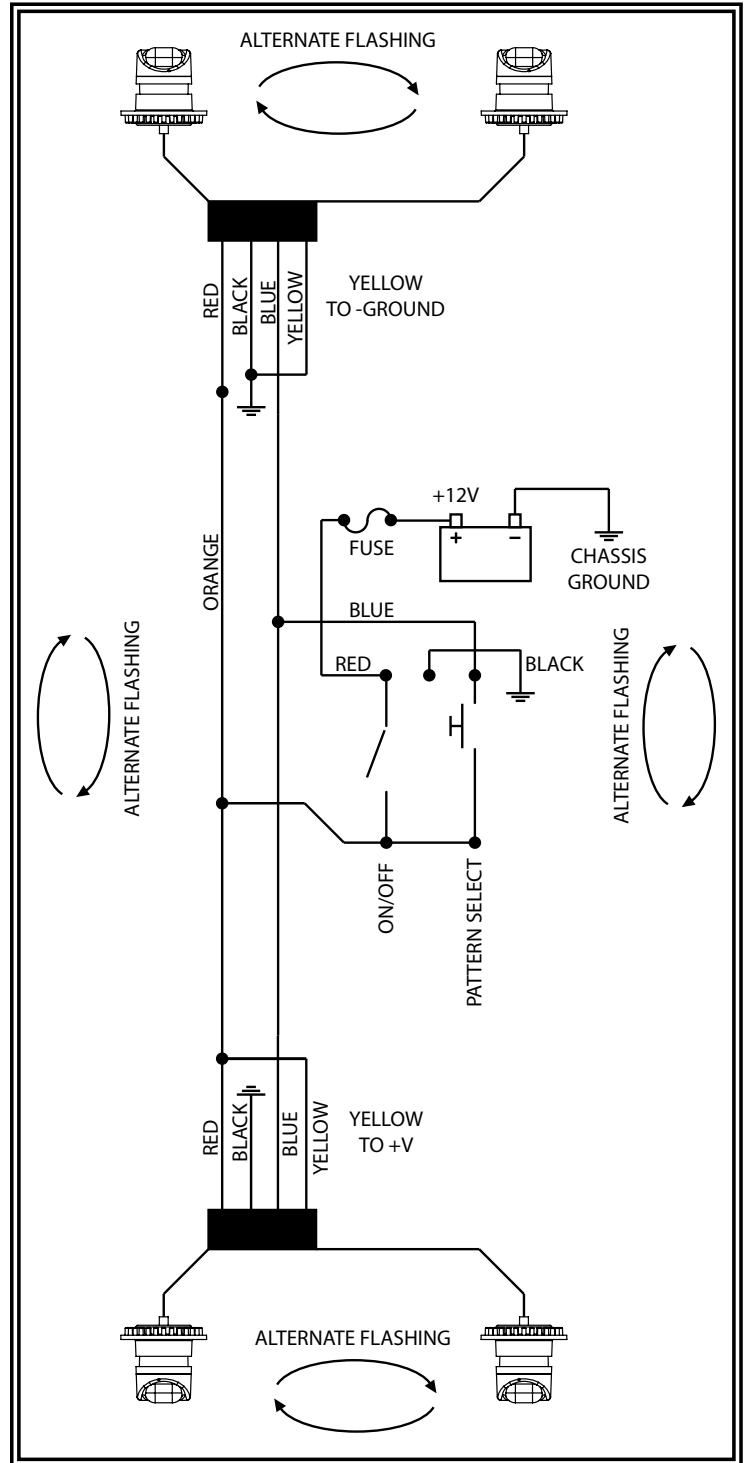

Flash Patterns:

POWER-UP RESET:

After installing the system it is best to do a POWER-UP RESET the first time to ensure that all heads are in sync.

Touch **BLUE** wires to +V (**RED** wire) while applying power.

Release **BLUE** wires. All heads will reset to Pattern #2.

If you have installed a pattern select push-button, press and hold pattern select while turning power switch ON.

To select a flash pattern, touch **BLUE** to +V or press pattern select switch to increment the flash pattern. The heads will remember the selected pattern even if power is removed.

STANDARD PATTERNS			
#	Pattern:	Frequency:	Description:
1	Quad Flash	1.25 Hz	75 Quad Flashes Per Minute
2	Double Flash	1.25 Hz	75 Double Flashes Per Minute
3	Triple Flash	1.53 Hz	92.3 Triple Flashes Per Minute
4	DeciBlast	1.42 Hz	85.5 Deci Flashes Per Minute
5	Single Flash	1.25 Hz	75 Single Flashes Per Minute
6	Mega Flash	1.90 Hz	114 Single Flashes Per Minute
7	Triple+Burst	1.37 Hz	82.5 Triple+Burst Flashes Per Minute
8	Fast Mega	3.0 Hz	180 Single Flashes Per Minute
CYCLE PATTERNS			
9	Cycle All		Cycle through patterns 1 to 7
10	Double-Triple+Burst		2 Double, 2 Triple+Burst cycle
11	Cycle Classic		1 Double, 1 Quad, 2 Mega cycle
12	Quad-Mega		3 Quad, 4 Mega cycle
13	Single-Quad		2 Single, 2 Quad cycle
14	DeciBlast-Quad		2 DeciBlast, 2 Quad cycle
15	Single-Triple-DeciBlast		2 Single, 2 Triple, 2 DeciBlast cycle
16	Mega-Triple+Burst		1 Mega, 1 Triple+Burst cycle

STANDARD PATTERNS:

The HIDE-A-LED™ ships with only the standard patterns enabled (1 through 8). To enable cycle flash patterns follow the procedure below.

CYCLE PATTERNS:

You may add patterns 9 through 16 by following this procedure:

1) Touch BLUE wires to +V (RED wire) while applying power.

If you have installed a pattern select push-button, press and hold pattern select while turning power switch ON.

2) Hold BLUE wires on +V for 5 SECONDS (heads will not be flashing during this time). After 5 SECONDS the heads will flash once or twice to indicate the flash pattern list that has been selected:

ONE FLASH = Standard Patterns only.

TWO FLASHES = Standard + Cycle patterns.

3) Remove the BLUE wires from +V (or release push-button).

You may switch the pattern set at any time as many times as you wish. All heads will remember the pattern set that was selected even when power is removed.

Troubleshooting:

HEAD NOT FLASHING:

Check the RED and BLACK wires for a reversed connection. (Reverse connection will not damage the unit).

Check RED and BLACK wires for either a bad splice or a corroded ground connection.

HEADS NOT SYNCHRONIZING:

Check for a short circuit on the BLUE wire to either +V or GROUND. Salt water on the wire connections will short circuit the sync signal on the BLUE wire. Check for non-functional heads in the system. If any one of the heads has a bad GROUND connection it can cause the sync signal to become corrupted. If any one of the heads has it's RED and BLACK wires reverse connected it will corrupt the sync signal.

FLASH PATTERN CHANGING:

If the flash pattern changes on it's own there may be an intermittent short between the BLUE wire and +V. Check for water in the wiring connections. If any one of the heads in the system has an intermittent GROUND connection it can also cause the flash pattern to change.