



BEACONS | MINIBARS | LIGHTBARS | WORKLAMPS | UTILITY BARS | INTERIOR LIGHTING | BACK-UP ALARMS | CAMERA SYSTEMS

DIRECTIONALS

9021 SERIES Dual Head Concealed Warning LED

The 9021 dual-head, concealed LED warning light is specifically designed for vehicle headlight and tail-light applications. The optic design produces wide-angle light dispersion and maximizes light reflected off the vehicle light casing. In addition, the LEDs' low profile allows mounting in small, confined light casings typical of tail lights and modern vehicle headlights. The LED design offers major advantages over strobe versions. All control electronics are situated in a sealed, in-line driver module so no remote power supply is required. 16 flash patterns are included, and multiple units can be synchronized to flash alternately or simultaneously. Additional benefits of LED technology include high intensity light output, low current draw and a long and maintenance free service life. And, they're covered by a full 5-year warranty.

Models

PART NO.	VDC	AMPS	FLASH PATTERNS	ILLUMINATION COLOR(S)	MOUNT
9021XX	12-24	1.0	16	Choose Color	1" Hole

Replace X in part number with desired LED color(s): A = amber, B = blue, C = clear, R = red

Features and Benefits

- Dual-head design eases installation and reduces cost.
- Four 1-watt, high-intensity LED's per head provide exceptional warning
- 16 Flash patterns including single, double, triple, quad, deci and cycle all
- Multiple heads are synchronizable (simultaneous or alternating operation)
- In-line waterproof driver module eliminates the need for a remote power supply
- UV stabilized polycarbonate lens, nickel plated housing and 9' cable
- CE, R10
- Warranty: 5 years

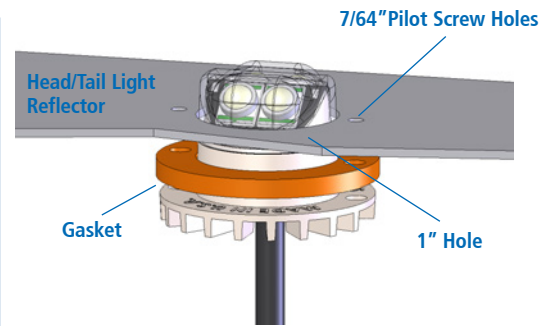

LED HEAD

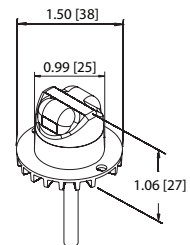

DRIVER MODULE

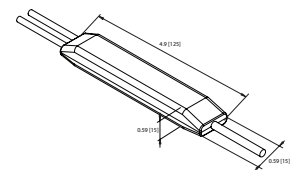

Solid Color:

- 160+ Lumens
- 155+ Lumens
- 660+ Lumens
- 123+ Lumens

DIRECTIONALS

Flash Patterns

Flash patterns are selected by touching the blue wire momentarily to power; the LED head will cycle through the available patterns.

STANDARD PATTERNS			
#	PATTERNS	FREQUENCY	DESCRIPTION
1	Quad Flash	1.25 Hz	75 Quad FPM
2	Double Flash	1.25 Hz	75 Double FPM
3	Triple Flash	1.25 Hz	92.3 Triple FPM
4	Deciblast	1.25 Hz	85.5 Deci FPM
5	Single Flash	1.25 Hz	75 Single FPM
6	Mega Flash	1.25 Hz	114 Single FPM
7	Triple+Burst	1.25 Hz	82.5 Triple + Burst FPM
8	Fast Mega	1.25 Hz	180 Single FPM

CYCLE PATTERNS			
#	PATTERNS	FREQUENCY	DESCRIPTION
9	Cycle All		Cycle through patterns 1 to 7
10	Double-Triple + Burst		2 Double, 2 Triple + Burst cycle
11	Cycle Classic		1 Double, 1 Quad, 2 Mega cycle
12	Quad-Mega		3 Quad, 4 Mega cycle
13	Single-Quad		2 Single, 2 Quad cycle
14	DeciBlast-Quad		2 DeciBlast, 2 Quad cycle
15	Single-Triple-DeciBlast		2 Single, 2 Triple, 2 DeciBlast cycle
16	Mega-Triple+Burst		1 Mega, 1 Triple+Burst cycle

Alternating/Simultaneous Flash Selection

The yellow wire on each LED head is used to determine alternating or simultaneous operation with other heads in the system that are connected using the blue wire. The yellow wire has no function when 'Steady On' flash pattern is selected.

- Connect the YELLOW wire to either POWER or GROUND
- Heads with YELLOW connected to POWER fire SIMULTANEOUSLY with other heads connected to POWER
- Heads with YELLOW connected to GROUND fire SIMULTANEOUSLY with other heads connected to GROUND
- Heads with YELLOW connected to POWER fire ALTERNATELY with other heads connected to GROUND

Note: The blue wires of all LED heads must be connected together for the alternating/simultaneous function to operate.

Wiring Diagram

The diagram below shows a typical installation of two dual head HIDE-A-LEDs™ using an on/off & pattern select switch. The front and rear pair of heads are configured to flash alternately with each other using the blue wire to connect the two with the yellow wire on one connected to ground and the yellow wire on the other connected to power.

The two heads on each dual head HIDE-A-LED™ are prewired to flash alternately with each other.

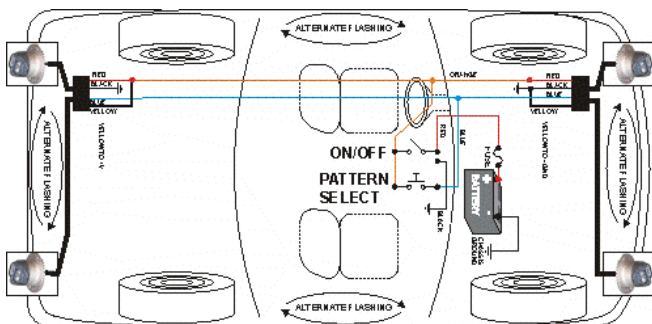

For ease of installation, all dual head products incorporate a connector between the LED head and power module. This will allow you to route the wires from each head individually to the power module eliminating the need to drill large pass thru holes. If installed in a wet area the connections can be sealed with RTV as shown below.

