

REVISION HISTORY

| REV. | DESCRIPTION | DATE |
|------|--|------------|
| A | INITIAL RELEASE PER CR# 1138 | 2004-06-14 |
| B | UPDATED FORMAT AND ADDED LENS CHART PER P09041 | 2009-11-12 |
| C | REVISE PER V13029 | 2015-08-24 |

SPECIFICATIONS

- CERTIFICATIONS: ECE R10; SAE J845 (JUN 2013) CLASS 1; YELLOW; Reg 65 CertType T Class 1; IP54
 Note: Unique components, accessories, and hardware kits are not typically Included in the Product Certification Test Protocols. Unless otherwise Specified, the Product Certifications referred to herein are predicated upon the base product model configuration.
- FLASH MODE: SINGLE : 205 ± 5 FLASHES PER MINUTE
- VOLTAGE (NOMINAL): 12 VDC
- VOLTAGE (EXTREME): 9.0 to 16.0 VDC
- CURRENT (PEAK): 4.86A (@ 12 VDC NOMINAL)
- POWER (MAXIMUM): 62.2W (@ 12 VDC NOMINAL)
- TEMPERATURE RANGE: -22°F (-30°C) TO 122°F (50°C)
- CONNECTION: 2-16 AWG LEAD WIRES
- MOUNTING: 3 BOLTS, FLUSH MOUNT
- BASE MATERIAL: POLYCARBONATE
- LENS MATERIAL: ACRYLIC
- PRODUCT WEIGHT: 1.1 LBS (0.5 Kg)

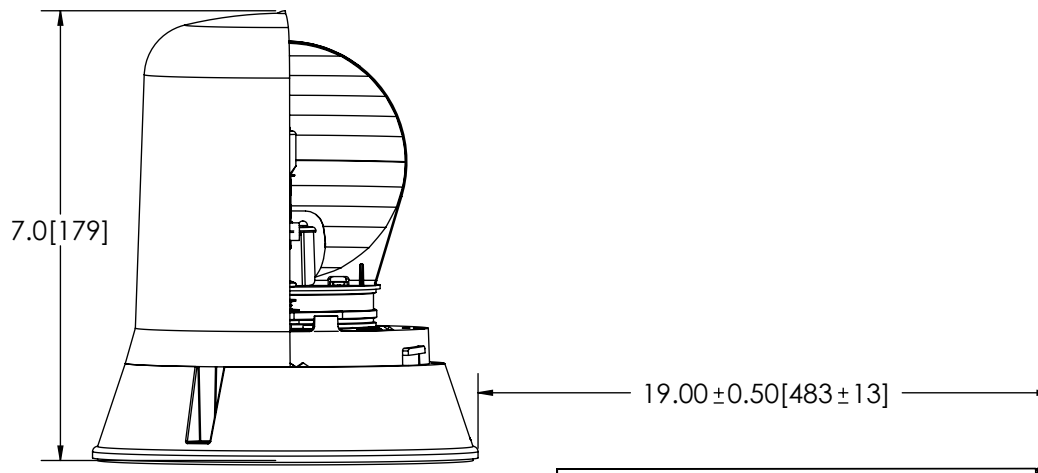
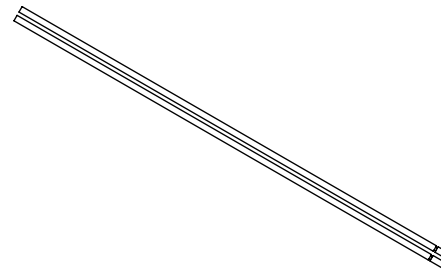
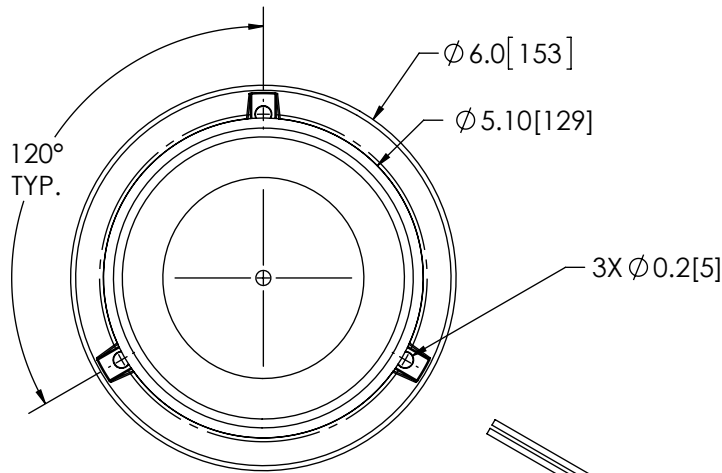

| COLOR CHART | |
|-------------|-------|
| FGS P/N | COLOR |
| 5840A | AMBER |

| SCALE 1:3 | | APPROVALS | DATE | |
|--|--|---|-----------|------------|
| CAD GENERATED DRAWING DO NOT MANUALLY UPDATE. MODEL REFERENCED:A | | DRAWN BY | ABB | 2015-08-19 |
| | | CHECKED | ABD | 2015-08-19 |
| TOLERANCES ARE IN INCHES, AND MILLIMETERS TOLERANCES UNLESS OTHERWISE STATED ARE: | | MECH. ENG. | KLR | 2015-08-19 |
| | | ELEC. ENG. | TJT | 2015-08-19 |
| MILLIMETERS DECIMALS XX. ± 1.0mm XX.X ± 0.5mm | | INCHES DECIMALS X.X ± 0.1 X.XX ± 0.04 X.XXX ± 0.02 | ANGLES | ± 0.5° |
| | | | FRACTIONS | ± 1/64 |
| | | TEST ENG. | JRT | 2015-08-19 |
| | | SALES. | LAT | 2015-08-19 |



| | | |
|--|-----------------------|--|
| LIGHT, ROTO, AMBER, 12V, FLUSH MOUNT | | |
| CUSTOMER PART NO. SEE CHART | | PRODUCT SERIES: 5800 |
| SIZE: A | DWG. NO. 5840A | REV. C |
| Electronically Controlled Use Latest Copy SHEET 1 OF 1 | | Project: CR# 1138 Date Created: 2003-12-22 |

NON DISCLOSURE AGREEMENT

THIS DRAWING AND THE DESIGN IT DISCLOSES ARE THE PRIVATE PROPERTY OF ESG AND IS ISSUED IN CONFIDENCE FOR ENGINEERING INFORMATION ONLY. THE DRAWING AND / OR DESIGN MAY NOT BE USED, COPIED, REPRODUCED, OR OTHERWISE DISCLOSED IN PART OR AS A WHOLE TO OUTSIDERS OR USED FOR ANY OTHER PURPOSE WITHOUT THE PRIOR WRITTEN CONSENT OF ESG. THE DRAWING IS SUBJECT TO RECALL AT ANY TIME. YOUR POSSESSION OF THIS DOCUMENT CONSTITUTES ACCEPTANCE OF THESE TERMS. © 2003 ECCO

