



BEACONS | MINIBARS | LIGHTBARS | DIRECTIONALS | WORKLAMPS | UTILITY BARS | INTERIOR LIGHTING | CAMERA SYSTEMS

BACK-UP ALARMS

575 SERIES

The 575 Series provides a high dB(A) alarm in a compact housing for use in less arduous environments where ambient noise level is high. ECCO specifically designed these products to meet our quality standards, yet provide a cost-considerate product. The reinforced nylon housing provides rugged durability and the epoxy-encapsulated circuit board protects the electronics from vibration and moisture. ECCO's unique grill design meets the requirements of SAE J994 for high-pressure washing. The 575 provides a high dB(A) alarm with exceptional reliability at a reasonable cost.

Models

PART NO.	VOLTAGE	dB(A)	AMPS	APPROVALS
575	12-24	107	0.9	SAE Type B, CE, R10 UL

Features and Benefits

- Compact size and universal mounting bracket maximizes location options
- Reverse polarity, voltage spike and surge protected
- Works on positive and negative ground systems
- Epoxy sealed to protect against dust, moisture and vibration
- Temperature Range: -40°F to +185°F (-40°C to +85°C)
- 2 Year Warranty

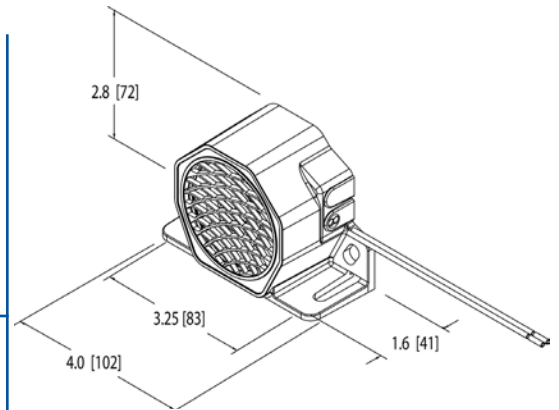

Alarm Specifications

- Connection: 16 AWG blunt cut wires
- Reinforced nylon housing
- Recommended mounting bolt: 1/4" Grade 5
- Recommended washer: 1/4" Type A, Series N or W
- Recommended mounting torque: 76 in. lbs.