

| REVISION HISTORY | | |
|------------------|----------------------------------|------------|
| REV. | DESCRIPTION | DATE |
| D | UPDATED DIMENSIONS PER P3 #06063 | 2007-09-24 |
| E | REVISE PER P11043 | 2012-10-26 |
| F | REVISE PER P11043 | 2016-06-23 |

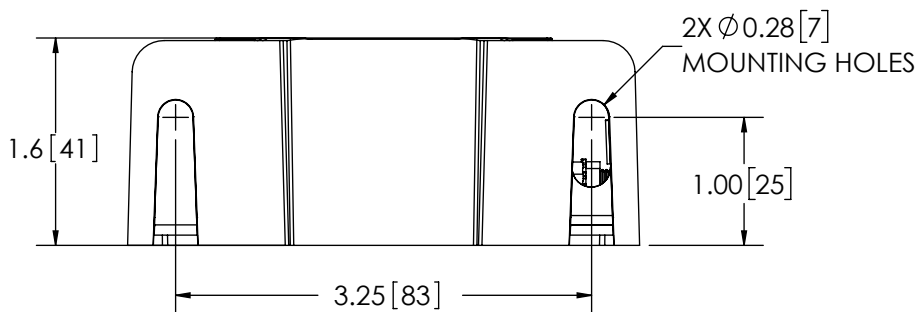
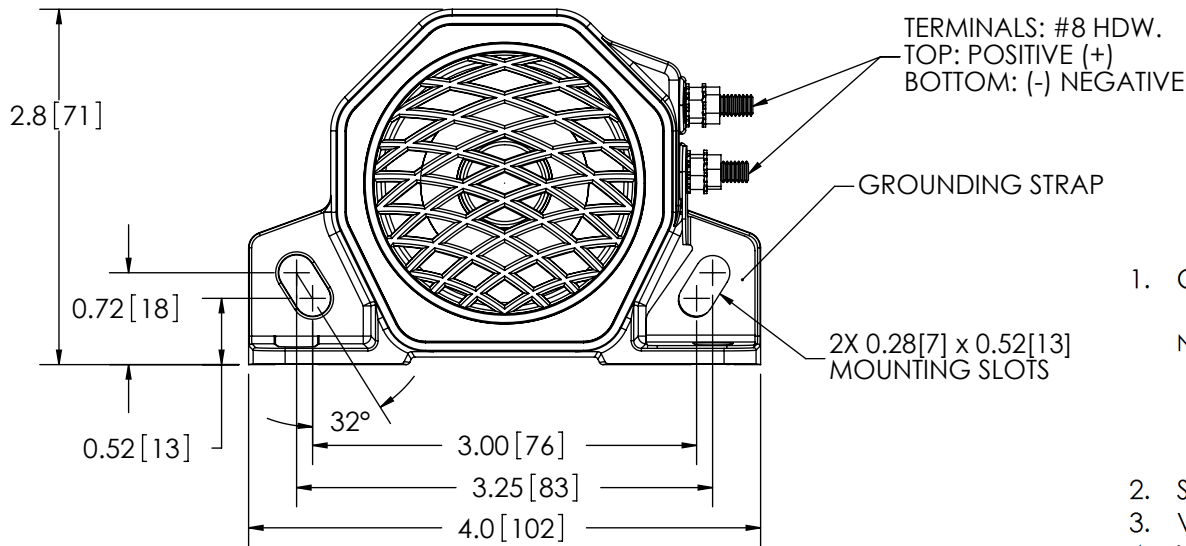

SPECIFICATIONS

- CERTIFICATIONS: **CE**; **UL**; ECE R10; SAE J994 (AUG 1993)
TYPE F; IP-65D

Note: Unique components, accessories, and hardware kits are not typically included in the Product Certification Test Protocols. Unless otherwise Specified, the Product Certifications referred to herein are predicated upon the base product model configuration.

- SOUND PRESSURE LEVEL: 102 ± 4 dB (A) @ 1.2m (4ft)
- VOLTAGE (NOMINAL): 12 to 24 VDC
- VOLTAGE (EXTREME): 9.0 to 32.0 VDC
- CURRENT (PEAK): 1.04 A (@ 12 VDC NOMINAL)
- POWER (MAXIMUM): 14.6 W (@ 12 VDC NOMINAL)
- TEMPERATURE RANGE: -40°F (-40°C) TO 185°F (85°C)
- FREQUENCY: 960 to 1440 Hz
- CONNECTION: 8 - 32 UNI STUD CONNECTION
- RECOMMENDED MOUNTING: 1/4 - 20 UNC, GRADE 5 OR BETTER, 1/4" TYPE A, SERIES N OR W WASHER
- HOUSING MATERIAL: GLASS FILLED NYLON
- PRODUCT WEIGHT: 0.7 LBS (0.32 Kg)

- NOTES:
- ROHS COMPLIANT
 - DIMENSIONS IN INCHES [MILLIMETERS (FOR REFERENCE)]

| SCALE 1:1.5 | | APPROVALS | DATE | ECCO® | |
|--|---|---|------|--|-------------------------------|
| CAD GENERATED DRAWING DO NOT MANUALLY UPDATE. MODEL REFERENCED: C | | DRAWN BY MDH | | ALARM, BACK-UP, 102DBA, 12-24 VDC | |
| TOLERANCES ARE IN INCHES, AND MILLIMETERS TOLERANCES UNLESS OTHERWISE STATED ARE: | | CHECKED MDH | | | |
| MILLIMETERS DECIMALS XX. ± 1.0mm XX.X ± 0.5mm | INCHES DECIMALS X.X ± 0.1 X.XX ± 0.04 X.XXX ± 0.02 | MECH. ENG. JLA | | | |
| | | ELEC. ENG. JES | | | |
| | | TEST ENG. JRT | | CUSTOMER PART NO. 530 | PRODUCT SERIES: 500 |
| | | SALES. DMV | | SIZE: A | DWG. NO. 530 |
| THIRD ANGLE PROJECTION | | Electronically Controlled Use Latest Copy | | SHEET 1 OF 1 | Project: CR# 602 |
| | | | | Date Created: 2000-11-21 | REV. F |

THIS DRAWING AND THE DESIGN IT DISCLOSES ARE THE PRIVATE PROPERTY OF ESG AND IS ISSUED IN CONFIDENCE FOR ENGINEERING INFORMATION ONLY. THE DRAWING AND / OR DESIGN MAY NOT BE USED, COPIED, REPRODUCED, OR OTHERWISE DISCLOSED IN PART OR AS A WHOLE TO OUTSIDERS OR USED FOR ANY OTHER PURPOSE WITHOUT THE PRIOR WRITTEN CONSENT OF ESG. THE DRAWING IS SUBJECT TO RECALL AT ANY TIME. YOUR POSSESSION OF THIS DOCUMENT CONSTITUTES ACCEPTANCE OF THESE TERMS. © 2000 ECCO