

REVISION HISTORY		
REV.	DESCRIPTION	DATE
01	PRELIMINARY RELEASE PER P14011	2016-11-08
02	REVISED PER P14011	2016-11-18
A	INITIAL RELEASE PER P14011	2016-11-29

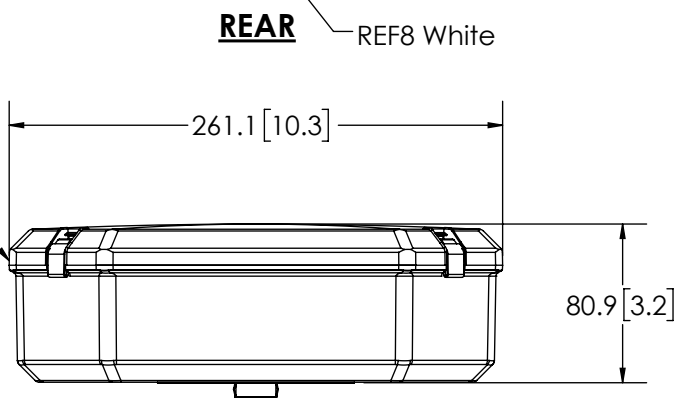
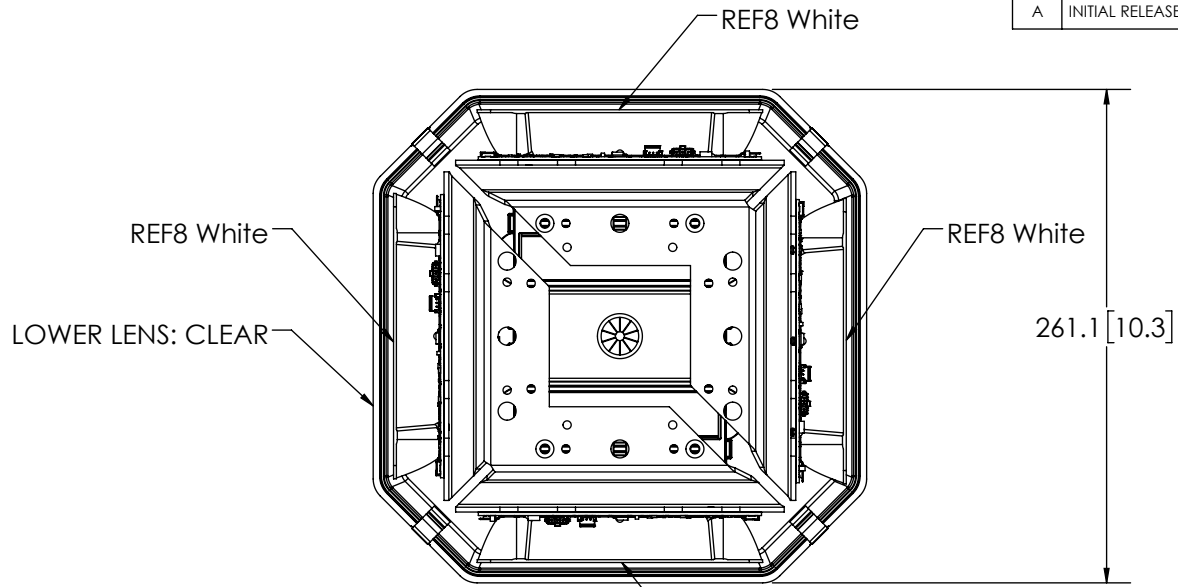

WIRING KEY		
COLOR	COMPONENT	TYP. MAX CURRENT (A)
RED	MAIN POWER	3.6A PEAK
BLK	GROUND	3.6A PEAK

SPECIFICATIONS

1. FLASH MODE: CYCLE FLASH
2. VOLTAGE (NOMINAL): 12 VDC
3. CURRENT (NOMINAL): SEE CHART
4. CONNECTION: 16 AWG WIRES IN CABLE
5. MOUNTING: PERMANENT MOUNTING KIT
6. BASE MATERIAL: ALUMINUM
7. LENS MATERIAL: POLYCARBONATE

- NOTES:**
1. CABLES AND WIRING NOT SHOWN
 2. TOP VIEW: TOP LENSES NOT SHOWN FOR CLARITY
 3. CABLE LENGTH - 4.5m [15.0'] FROM INTERNAL CONNECTOR
 4. DIMENSIONS IN MILLIMETERS [INCHES (FOR REFERENCE)]

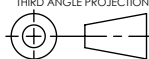
SCALE 1:4		APPROVALS	DATE	
CAD GENERATED DRAWING DO NOT MANUALLY UPDATE. MODEL REFERENCED: A		DRAWN BY	2016-11-18	
TOLERANCES ARE IN INCHES AND MILLIMETERS TOLERANCES UNLESS OTHERWISE STATED ARE:		CHECKED	ABB	2016-11-21
MILLIMETERS DECIMALS XX. ± 1.0mm XX.X ± 0.5mm	INCHES DECIMALS X.X ± 0.1 X.XX ± 0.04 X.XXX ± 0.02	MECH. ENG.		DUOBEAM, 27, 10"/0.26M, REF8, SNGL, C/C CUSTOMER PART NO. 27-DB002-E PRODUCT SERIES: DUO-BEAM
THIRD ANGLE PROJECTION		ELEC. ENG.		
		TEST ENG.		
		SALES.		
NON DISCLOSURE AGREEMENT		SIZE: A DWG. NO. 27-DB002-E REV. A		
THIS DRAWING AND THE DESIGN IT DISCLOSES ARE THE PRIVATE PROPERTY OF ESG AND IS ISSUED IN CONFIDENCE FOR ENGINEERING INFORMATION ONLY. THE DRAWING AND / OR DESIGN MAY NOT BE USED, COPIED, REPRODUCED, OR OTHERWISE DISCLOSED IN PART OR AS A WHOLE TO OUTSIDERS OR USED FOR ANY OTHER PURPOSE WITHOUT THE PRIOR WRITTEN CONSENT OF ESG. THE DRAWING IS SUBJECT TO RECALL AT ANY TIME. YOUR POSSESSION OF THIS DOCUMENT CONSTITUTES ACCEPTANCE OF THESE TERMS. © 2016 ECCO		Electronically Controlled Use Latest Copy SHEET 1 OF 1 Project: P14011 Date Created: 2016-11-07		