

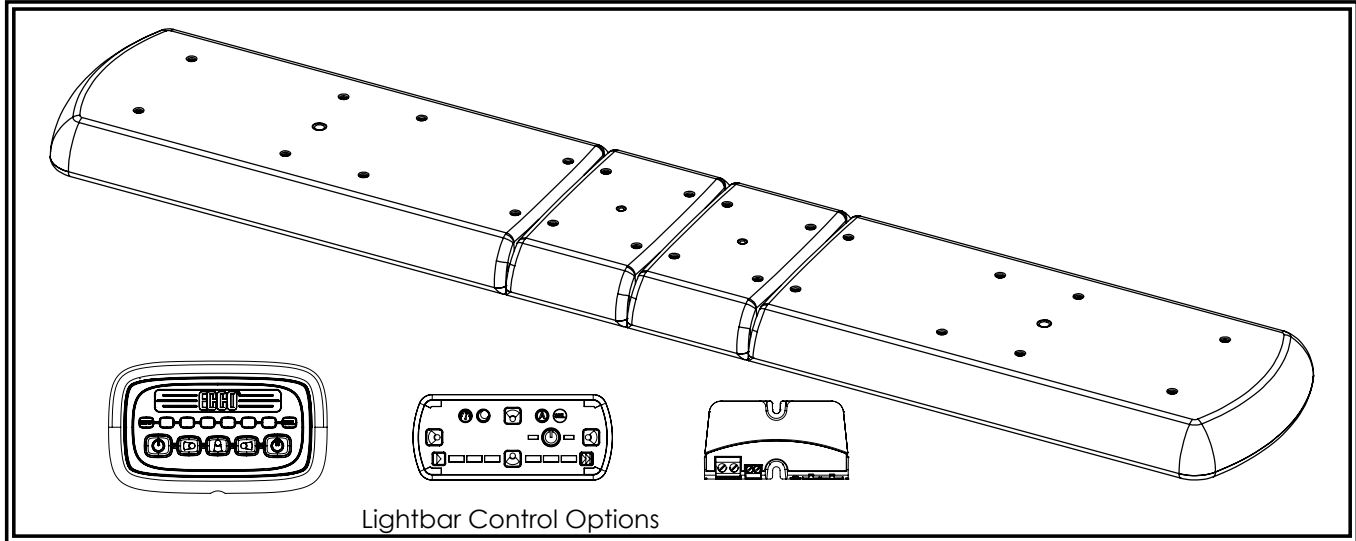

# ECCO® Installation and Operation Instructions 12+ Series Vantage™ Lightbars



## Introduction:

ECCO 12+ Series Lightbars are versatile and powerful warning devices suitable for a range of vehicle types and duties. There are numerous options and lengths available. The lightbars can either be mounted permanently to the vehicle or mounted using an optional roof mounting kit.

The 12+ Series Lightbar features a durable aluminum chassis, polycarbonate base and lens and has a sleek, low profile, suitable for many vehicle applications. The 12+ Series supports three different kinds of LED modules: Warning modules, Stop-Tail-Turn modules, and white Alley/Takedown/Worklight modules.

## Unpacking and Pre-Installation:

Carefully remove the lightbar and place it on a flat surface. Examine the unit for transit damage and locate all parts. If damage is found or parts are missing, contact the transit company or ECCO. Do not use damaged or broken parts.

Ensure the lightbar voltage is compatible with the planned installation.

**IMPORTANT!** Read all instructions before installing and using. Installer: This manual must be delivered to the end user. This manual assumes installation by a suitably qualified Automotive Technician.



**Do not install and/or operate this safety product unless you have read and understand the safety information contained in this manual.**

1. Proper installation combined with operator training in the use, care and maintenance of emergency warning devices are essential to ensure the safety of emergency personnel and the public.
2. Emergency warning devices often require high electrical voltages and/or currents. Exercise caution when working with live electrical connections.
3. This product must be properly grounded. Inadequate grounding and/or shorting of electrical connections can cause high current arcing, which can cause personal injury and/or severe vehicle damage, including fire.
4. Proper placement and installation is vital to the performance of this warning device. Install this product so that output performance of the system is maximized and the controls are placed within convenient reach of the operator so that s/he can operate the system without losing eye contact with the roadway.
5. It is the responsibility of the vehicle operator to ensure daily that all features of this product work correctly. In use, the vehicle operator should ensure the projection of the warning signal is not blocked by vehicle components (i.e., open trunks or compartment doors), people, vehicles or other obstructions.
6. The use of this or any other warning device does not ensure all drivers can or will observe or react to an emergency warning signal. Never take the right-of-way for granted. It is your responsibility to be sure you can proceed safely before entering an intersection, drive against traffic, respond at a high rate of speed, or walk on or around traffic lanes.
7. This equipment is intended for use by authorized personnel only. The user is responsible for understanding and obeying all laws regarding emergency warning devices. Therefore, the user should check all applicable city, state, and federal laws and regulations. The manufacturer assumes no liability for any loss resulting from the use of this warning device.
8. This product may contain high intensity LEDs staring directly into these lights could result in temporary and/or permanent vision impairment.



## WARNING!

Failure to install or use this product according to manufacturer's recommendations may result in property damage, serious bodily/personal injury, and/or death to you and those you are seeking to protect!

## Specifications:

Length.....48",54",60",72"  
 Height.....2.5" Width: 11"  
 Voltage.....12-24VDC  
 Current Draw.....Single Color LED Module = 0.45A Avg. @ 12.8VDC  
                           Dual Color LED Module = 0.90A Avg. @ 12.8VDC  
                           LED STT(pair) = 0.25A Avg.@ 12.8VDC  
                           LED AL,TD,WL (pair) = 1.80A Avg. @ 12.8VDC  
 Flash Patterns.....48 (See chart)

## Installation & Mounting:

### Mounting

Before proceeding with installation, plan all wiring and cable routing. Select the mounting location for the lightbar on a flat, smooth surface and center the unit across the width of the vehicle. The mounting location for the lightbar should be chosen such that the lightbar is level and visibility to approaching traffic is optimized. Mounting should be such that there is no less than 1/2" clearance between the roof and the lightbar at any point.



## Caution:

When drilling into any vehicle surface, make sure that the area is free from any electrical wires, fuel lines, vehicle upholstery, vehicle support members, etc. that could be damaged.

Safety Director Flash Pattern Chart		
Sequence	Description	SAE J595
1	Left	N/A
2	Left Build	N/A
3	Right	N/A
4	Right Build	N/A
5	Center Out	N/A
6	Center Out Build	N/A
7	Wig Wag	Class 1
8	Quad Alternate	Class 1
9	Quad Alternate Center Pulse	N/A
10	Single Alternate	Class 1
11	Single Alternate Center Pulse	N/A

NOTE: Unless otherwise configured, lightbars containing dual color modules will operate such that patterns referencing "Front" will operate color 1 and patterns referencing "Rear" will operate color 2; e.g. on an EZ1206AR dual color module, amber is color 1 and red is color 2.



35	Quad Alternate Front Center Pulse	150	-	-	-	-	-	-	-	-	-	-	-	-	-	-	-	-	-	-
36	Quad Alternate Rear	150	C1	C1	C1	C1	C1	-	C1	-	C1	-	C2	-	-	-	-	-	-	-
37	Quad Alternate Rear Center Pulse	150	-	-	-	-	-	-	-	-	-	-	-	-	-	-	-	-	-	-
38	Double Alternate Front	150	C1	C1	C1	C1	C1	-	C1	-	C1	-	C2	-	-	-	-	-	-	-
39	Double Alternate Front Center Pulse	150	-	-	-	-	-	-	-	-	-	-	-	-	-	-	-	-	-	-
40	Double Alternate Rear	150	C1	C1	C1	C1	C1	-	C1	-	C1	-	C2	-	-	-	-	-	-	-
41	Double Alternate Rear Center Pulse	150	-	-	-	-	-	-	-	-	-	-	-	-	-	-	-	-	-	-
42	Quint Hold Alternate Front	150	C1	C1	C1	C1	C1	-	C1	-	C1	-	C2	-	-	-	-	-	-	-
43	Quint Hold Alternate Front Center Pulse	150	-	-	-	-	-	-	-	-	-	-	-	-	-	-	-	-	-	-
44	Quint Hold Alternate Rear	150	C1	C1	C1	C1	C1	-	C1	-	C1	-	C2	-	-	-	-	-	-	-
45	Quint Hold Alternate Rear Center Pulse	150	-	-	-	-	-	-	-	-	-	-	-	-	-	-	-	-	-	-
46	Quint Alternate Middle	75	C1	C1	C1	C1	C1	-	C1	-	C1	-	C2	-	-	-	-	-	-	-
47	Quint Alternate Middle Center Pulse	75	-	-	-	-	-	-	-	-	-	-	-	-	-	-	-	-	-	-
48	Random	75	-	-	-	-	-	-	-	-	-	-	-	-	-	-	-	-	-	-

KEY:

C1: CLASS 1

C2: CLASS 2

D: DAY MODE

N: NIGHT MODE

NOTE:

1. All SAE J845 compliant patterns above at least 180° of coverage with the minimum configuration of two corner modules, one forward facing and one rear facing module.

## Permanent Mounting

1. Determine the location of the lightbar, and the best route for the wiring.
2. Determine the position of the mounting feet and drill the 5/16"-11/32" diameter mounting holes accordingly, if needed.  
The spacing of the mounting feet from left to right is adjustable. It is suggested that the positioning of the feet be symmetrical and near the curved edges of the roof where the roof is strongest. Ideally, the outermost holes on the feet should be used for installation. The inner holes on the feet match the hole locations for ECCO 15 series lightbar and can be used when one of these lightbars has been previously installed.
3. Mount the lightbar, with the bolts going through the holes drilled in step 2, routing the wire as planned in step 1 (refer to diagram). See the Wiring section of this manual for further wiring instructions. Install washers and nuts and secure the unit.

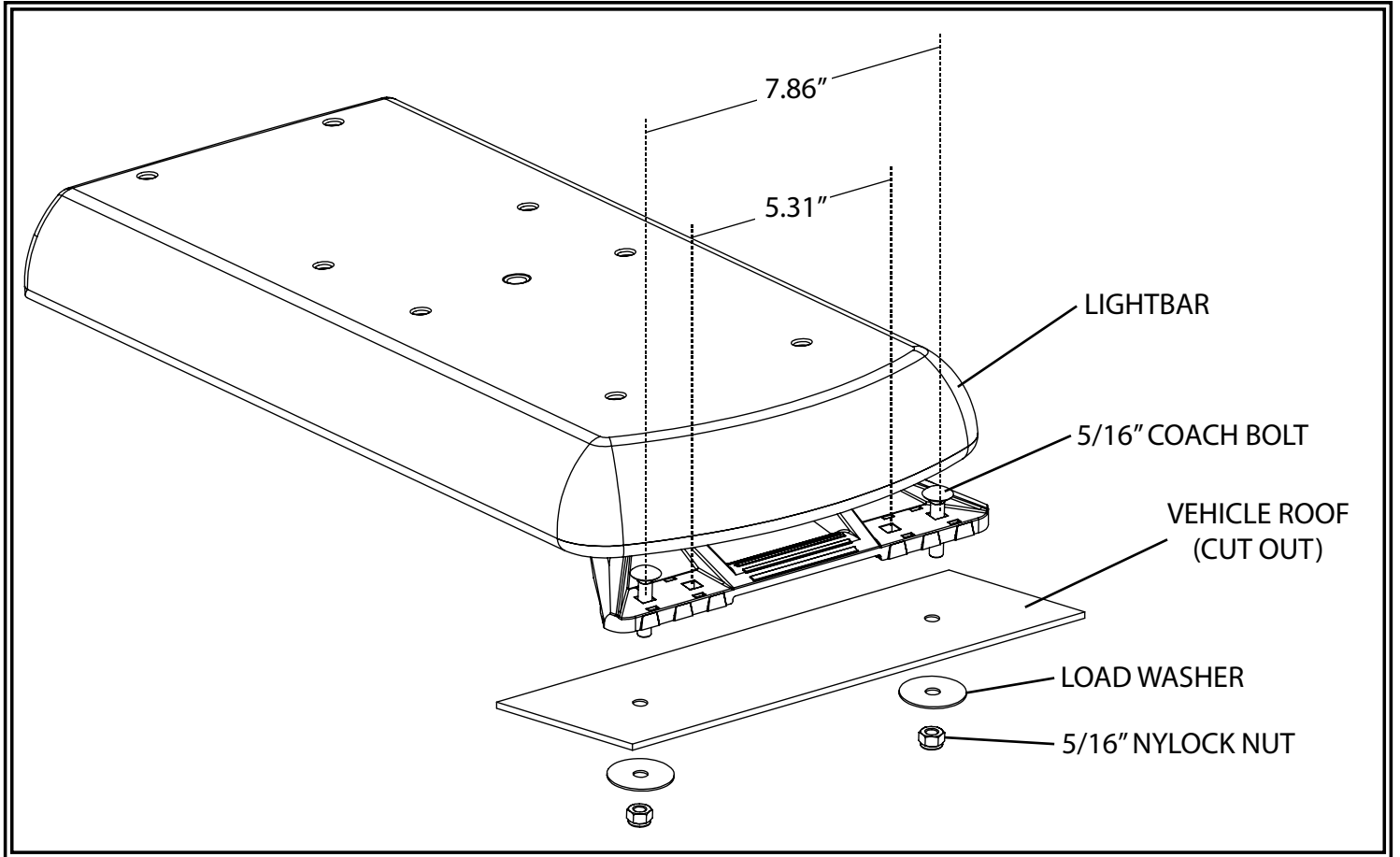

## Gutter Mounting

### Important!

Mounting brackets are specific to the vehicle model. Please make sure the brackets are suitable for the vehicle before installation.

1. Remove mounting foot. Position bracket onto nubs of the foot.
2. Holding the bracket and foot together, insert the cage nut as shown. It will fit snugly underneath the mounting foot. Do not install it on the outside face.
3. Install the mounting feet in reverse order of their removal. The metal bracket will be sandwiched between the bar and the composite mounting foot. Adjust the spacing of the mounting feet before securely tightening the nuts.
4. Hand thread the M6 bolt through the star washer and mounting strap into the cage nut. Be careful not to cross thread the bolt, and leave loose until later steps.
5. Once the bar is in position, use the strap as a template to drill  $\varnothing 1/8$ " holes. It may be necessary to pull back the door sealing gasket or trim. Apply silicone or sealant around the hole, behind the strap. Secure the straps with the provided #10 stainless steel sheet metal screws with washers as shown. Screws should be tightened around 5-10 in-lb.
6. Tighten the M6 bolts evenly so that the bar is even and centered. Reinstall any removed trim and/or weather-stripping and close doors to check secure fit of the lightbar.

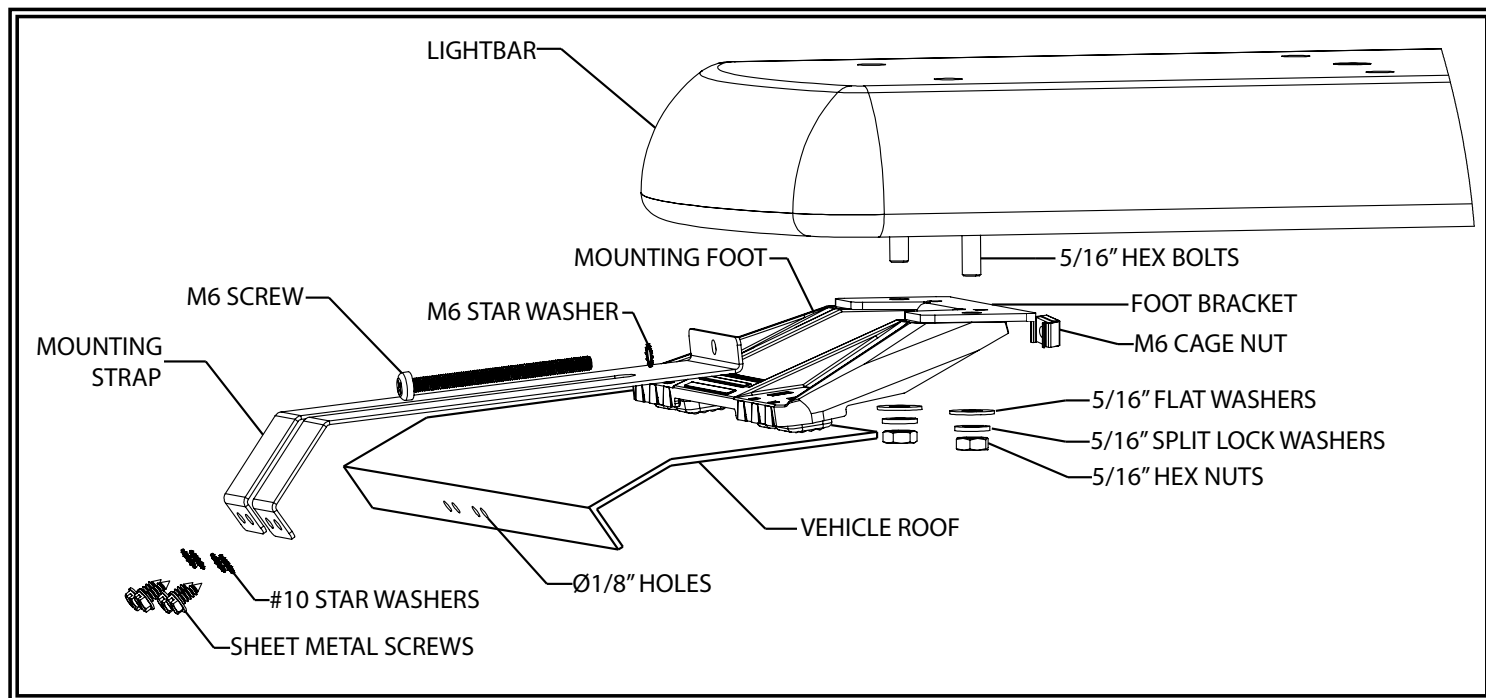

### 12+ Series Roof Mounting Kits

(Please call Customer Service for more options)

<u>Vehicle</u>	<u>P/N</u>
FORD, TRUCK, SUPERDUTY, '17	A1234RMK
FORD, TRUCK, F150, '15-'17	A1234RMK
DODGE, TRUCK, 1500, '09-'17	A1236RMK
CHEVY/GM, TRUCK, 1500, 2500, 3500, '14-'17	A1237RMK
GM, TAHOE/YUKON, '14-'17	A1237RMK
TOYOTA, TACOMA, '05-'17	A1238RMK
TOYOTA, TUNDRA, '15-'17	A1239RMK
HEADACHE RACK MOUNTING BRACKETS	A1032RMK

## Wiring Instructions:

### Important!

This unit is a safety device and it must be connected to its own separate, fused power point to assure its continued operation should any other electrical accessory fail. Do not wire in parallel with any other accessory.

### Notes:

1. Larger wires and tight connections will provide longer service life for components. For high current wires it is highly recommended that terminal blocks or soldered connections be used with shrink tubing to protect the connections. Do not use insulation displacement connectors (e.g., 3M Scotchlock type connectors).
2. Route wiring using grommets and sealant when passing through compartment walls. Minimize the number of splices to reduce voltage drop. High ambient temperatures (e.g., under-hood) will significantly reduce the current carrying capacity of wires, fuses, and circuit breakers. All wiring should conform to the minimum wire size and other recommendations of the manufacturer and be protected from moving parts and hot surfaces. Looms, grommets, cable ties, and similar installation hardware should be used to anchor and protect all wiring.
3. Fuses or circuit breakers should be located as close to the power takeoff points as possible and properly sized to protect the wiring and devices.
4. Particular attention should be paid to the location and method of making electrical connections and splices to protect these points from corrosion and loss of conductivity.
5. Ground termination should only be made to substantial chassis components, preferably directly to the vehicle battery.
6. Circuit breakers are very sensitive to high temperatures and will "false trip" when mounted in hot environments or operated close to their capacity.



### CAUTION!

**Disconnect the battery before wiring up the lightbar, to prevent accidental shorting, arcing and/or electrical shock.**

### General Wiring Instructions

Before attempting to connect the lightbar wiring harness, refer to the wiring diagram illustrated below. The wiring diagram describes the function for each separate wire.

1. Route the lightbar power cable's red wire to a fused, ignition-switched power point. Connect the black wire to a solid ground connection on the vehicle (ideally, directly to the battery negative terminal). Use a fuse according to the wiring diagram.
2. After the lightbar has been mounted, route the control cable into the vehicle to the switch panel/controller location.
3. Connect the wires of the lightbar wiring harness to the switched side of each switch, or plug into optional controller. See the wiring diagram for wire color/function legend.
4. Use cable ties and grommets to secure and protect all cables and wires.

# Wiring Diagram

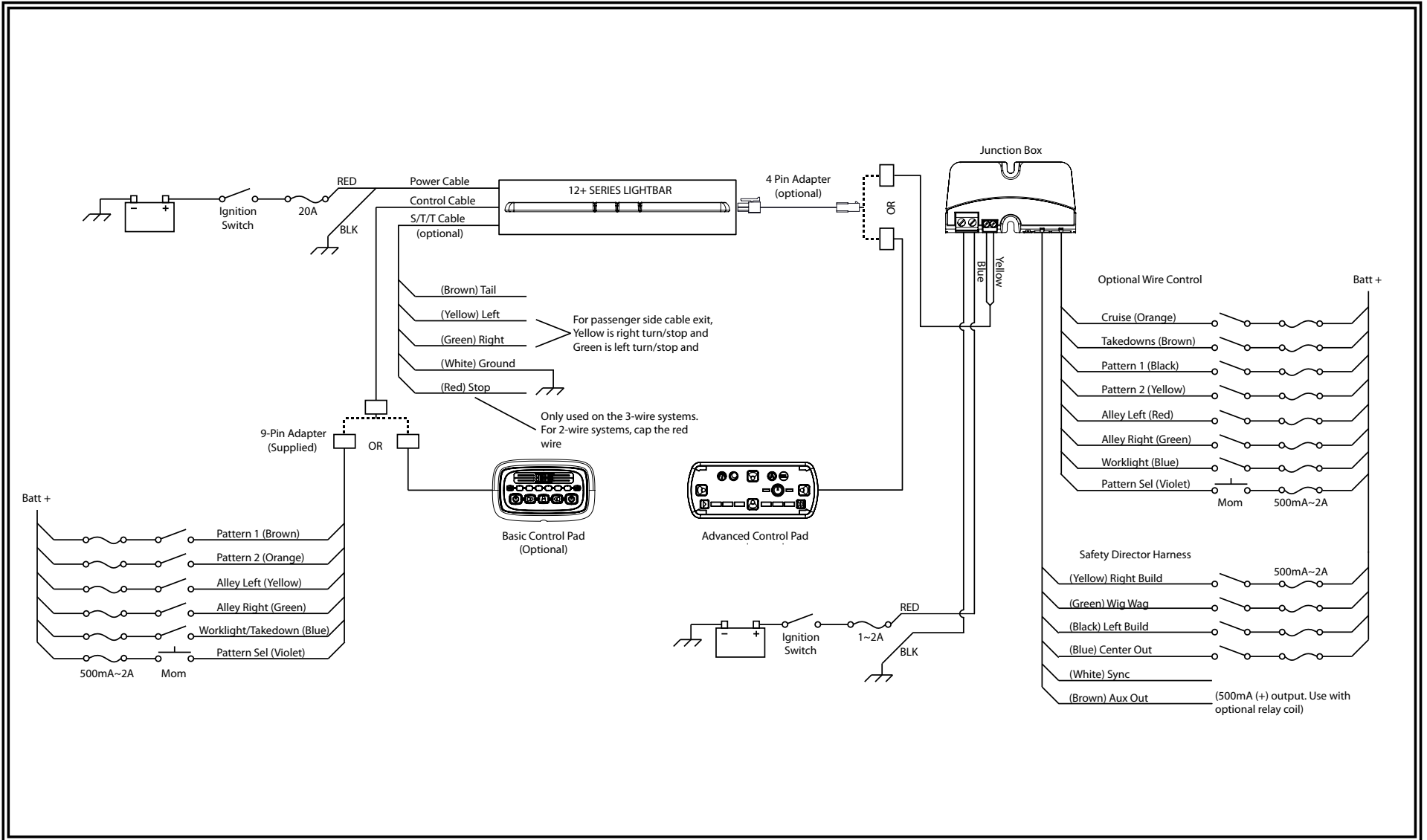



## Options and Maintenance:

Occasional cleaning of the lenses will ensure optimum light output. Take care when cleaning lenses – although tough, polycarbonate scratches easily. Clean the lens and base with soap and water or a lens polish using a soft cloth. Do not use solvents as they may damage the polycarbonate. Do not subject the lightbar to high-pressure washers or automatic car washers.

### Lens Removal and Installation

1. Remove the screws from the lenses. Starting at one edge, pull the lens off.
2. Carefully lift the lens off the seal – choose a suitable location to temporarily store the lens so as to not scratch the surface.
3. When reinstalling, gently apply pressure around the lens taking care not to damage the seal. Replace the screws.

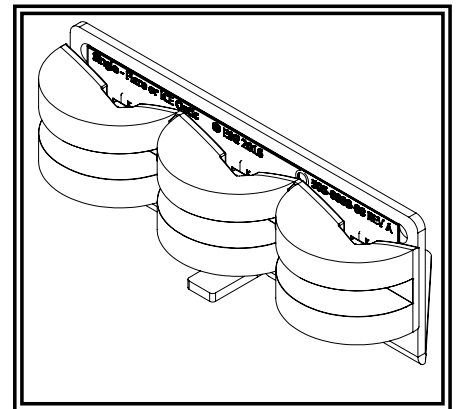
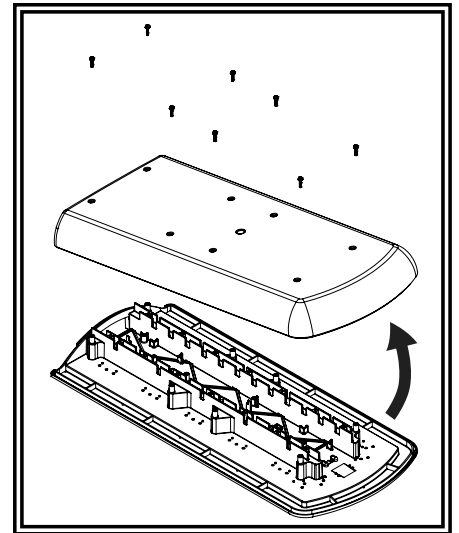

### Warning LED Modules (EZ1201X, EZ1203X, EZ1206XX)

The LED lightheads have been designed to ensure long service life using high performance LEDs. The modules are low profile units that have a high intensity output with low current draw. The LED lightheads can be mounted in the front, rear and corners of the lightbar.

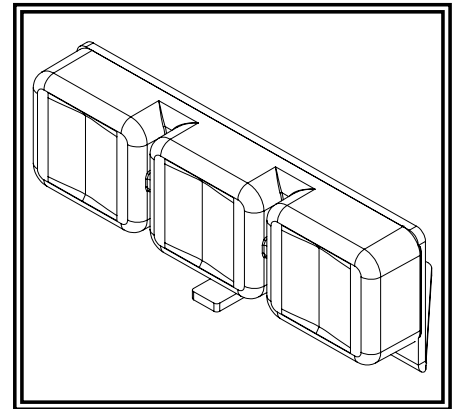

### Alley / Takedown / Worklight LED Modules (EZ0003)

Alley / Takedown / Worklight LED Module can be mounted anywhere in the lightbar.

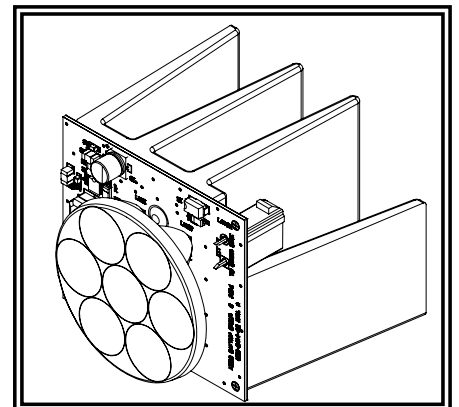

## Stop / Tail / Turn LED Modules (EZ1205)

Stop Tail Turn modules operate in conjunction with the vehicle tail, brake and direction indicator lights. Kit includes a pair of modules, control circuit and cable.

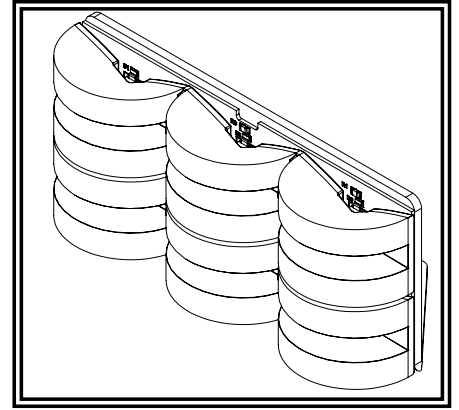

## Basic Control Pad (EZ0006)

The EZ0006 optional in-cab controller provides convenient control of the lightbar's built-in flash patterns and features soft touch buttons and LED function indicator lights.

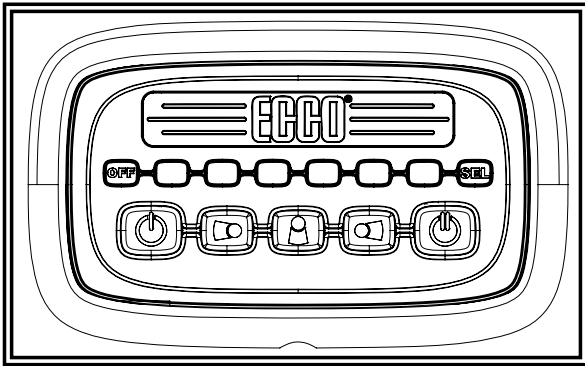

### Operation

The 12+ series basic control pad consists of 7 buttons with 5 features, and 6 indicator windows. When a feature button is selected, the corresponding clear indicator(s) will illuminate. Pressing any of the 5 feature buttons will turn that corresponding feature on, pressing it again will turn it off. There are two large flash pattern preset buttons; only one can be selected at a time. If one is on while the other is selected, it will shut the previous one off. The "OFF" and "SEL" buttons do not have illuminated indicators.



**"OFF"** - Turns the whole bar off. This is a quick way to shut everything down. Features can also be shut down individually by pushing the feature's button.

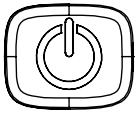

**"Power 1, Power 2"** - Turns on the flash pattern presets.

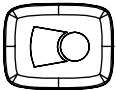
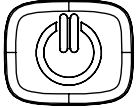

**"AL"** - Turns on left alley light, or as custom configured.

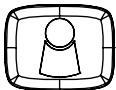

**"WL"** - Turns on center pair of takedown and/or worklights, or as custom configured.

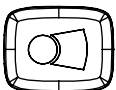

**"AR"** - Turns on right alley light, or as custom configured.



**"SEL"** - Double press to enter flash pattern select mode and cycle to the next flash pattern. Press again to cycle to the next flash pattern. Press and hold for 3 seconds to return to the prior flash pattern. The lightbar will store the last flash pattern used to the active preset.

## Advanced Control Pad (EZ1202)

The EZ1202 optional in-cab advanced control pad provides convenient control of the lightbar's built-in flash patterns and features soft touch buttons and LED function indicator lights.

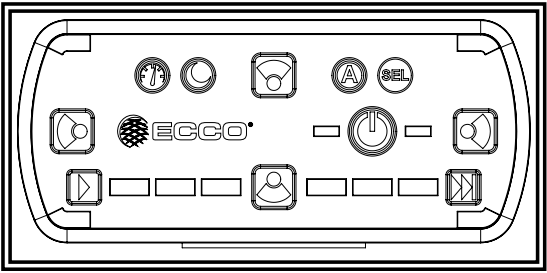

### Operation

The 12+ series advanced control pad consists of 11 buttons.

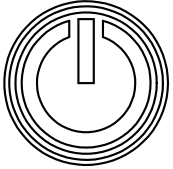

**“Power”** - Press to cycle through three programmable flash pattern presets. Hold button down to shut down all functions. Press again to resume as before.

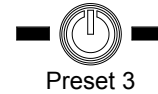
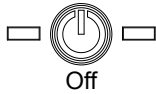

**“Cruise”** - Press to illuminate all directional modules in steady burn mode.

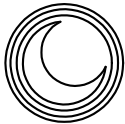

**“Day/Night Mode”** - Press to backlight the keypad and lower the brightness of the directional modules in the lightbar.



**“Auxiliary Output”** - For use with the auxiliary output from the junction box to a relay (customer supplied), to control any auxiliary device via the junction box controlled relay.



**“Flash Pattern Select”** - Double press to enter flash pattern select mode and cycle one flash pattern. The 4 corner LEDs on the controller will mimic the lightbar to give pattern feedback. Press again once to cycle to the next flash pattern. Press and hold for 3 seconds to return to the prior flash pattern. The lightbar will store the last flash pattern used to the active preset.

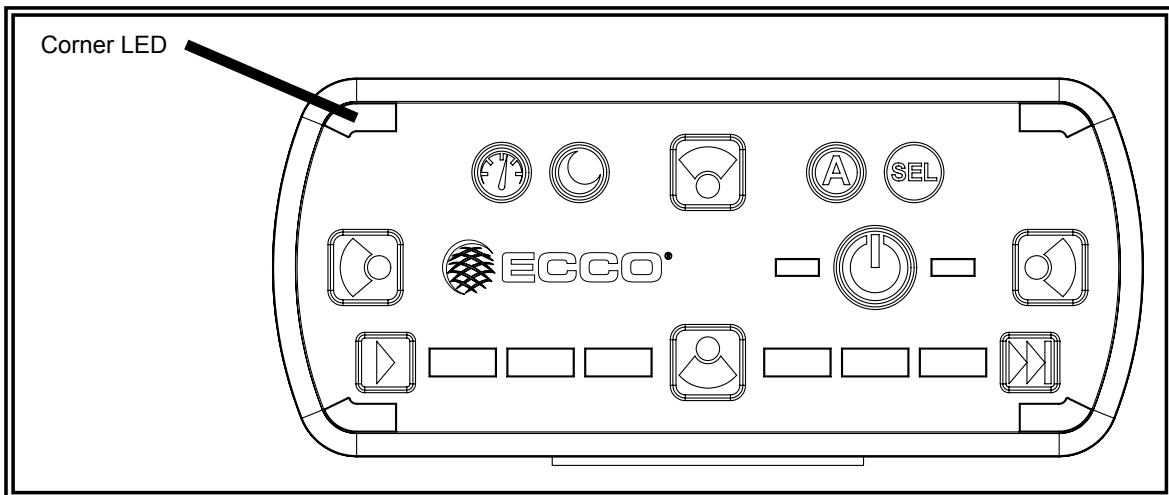

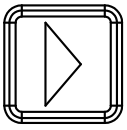

“Safety Director On/Off” - Will resume pattern selected.

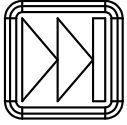

“Safety Director Pattern Select” - Press once to cycle to the next Safety Director flash pattern. There is a 5 second delay between the controller and the lightbar. Press and hold for 3 seconds to return to the prior flash pattern. The lightbar will store the last flash pattern used.

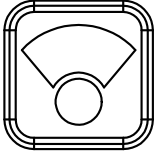

“Forward Worklamp” - Will turn on forward facing worklamps.

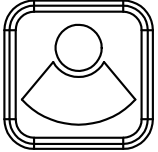

“Rear Worklamp” - Will turn on rear facing worklamps.

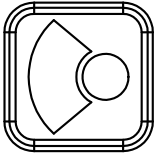

“Alley Left” - Will turn on the left alley light.

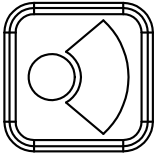

“Alley Right” - Will turn on the right alley light.

### Special Features:

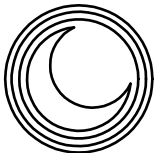

#### Touchpad Backlight

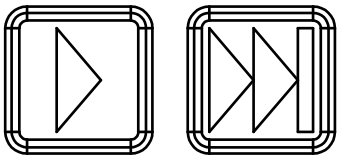

Press and hold the “Day/Night” button to turn on the touchpad backlight

#### Safety Director Module Selection



To change the number of modules used in the safety director, press and hold  - tap  to select 6 to 10 modules.

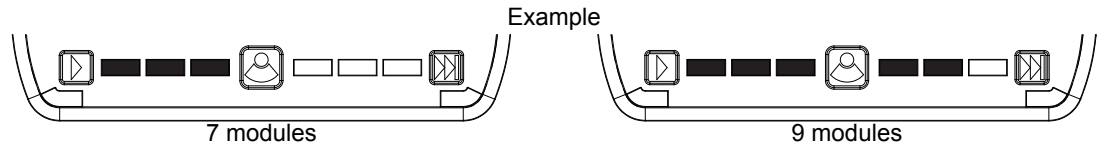

#### Safety Director Front/Rear Selection

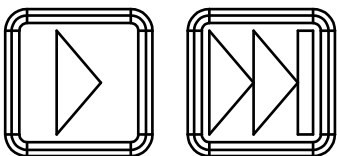

Press  to turn on the safety director.

Press and hold  , once the corner LEDs light, tap  to cycle front, rear or both.

### Basic Control Pad Mounting:

To mount the control pad with Velcro, separate the two circular halves, remove the backing and adhere one piece on the vehicle dashboard and adhere the other to the back of the control pad. To mount the control pad using the swivel mount, first mount the swivel unit to the dashboard with either the supplied screws (note, the suction cup will not work after drilling screws through the swivel base) or by turning the lever at the base of the swivel unit to engage the suction cup. Push the control pad onto the swivel slide and press the control pad down onto the slide until it engages the slot in the control pad. (You may need to turn the control pad clockwise once engaged with the slide to tighten it.) Turn the dial on the swivel head to tighten it against the back of the control pad. Finally, loosen the hand screw on the swivel neck to adjust the angle of the control pad. Hold the pad in the desired position while tightening the hand screw on the swivel neck.

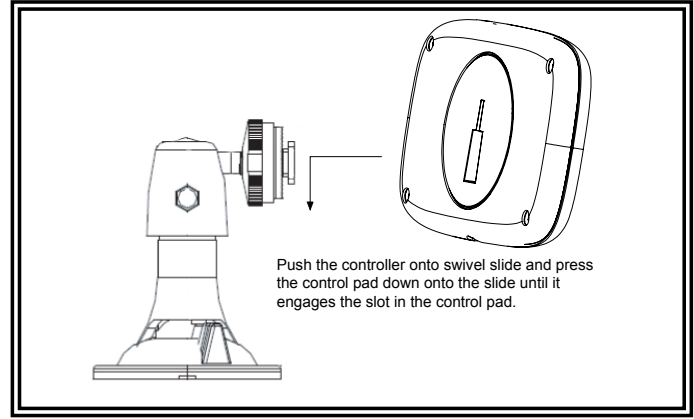

### Advanced Control Pad Mounting:

The advanced control pad is supplied with three mounting options: a bracket, VHB tape and hook and loop patch. The rear of the control pad is designed to allow for the cable exit to be routed five different ways to maximize installation locations. Mount the control pad in a location within convenient reach of the operator so that s/he can operate the system without losing eye contact with the roadway.

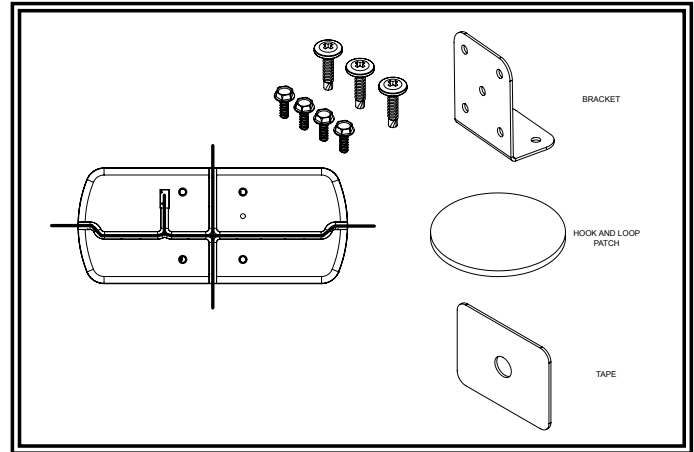

## Replacement Parts/Accessories:

Description	Part No.
<b>Lenses</b>	
REPLACEMENT END LENS	ER0003
REPLACEMENT MID LENS	ER0004
<b>LEDs</b>	
ACC,MODULE,LED,12+ SER,AMBER	EZ1203A
ACC,MODULE,LED,12+ SER,BLUE	EZ1203B
ACC,MODULE,LED,12+ SER,RED	EZ1203R
ACC,MODULE,LED,12+ SER,GREEN	EZ1203G
ACC,MODULE,LED,12+ SER,WHITE	EZ1203W
ACC,MODULE,LED,12+ SER,AMBER/BLUE	EZ1206AB
ACC,MODULE,LED,12+ SER,AMBER/WHITE	EZ1206AW
ACC,MODULE,LED,12+ SER,AMBER/RED	EZ1206AR
ACC,MODULE,LED,12+ SER,BLUE/WHITE	EZ1206BW
ACC,MODULE,LED,12+ SER,RED/WHITE	EZ1206RW
ACC,MODULE,LED,12+ SER,RED/BLUE	EZ1206RB
ACC,MODULE,LED,12+ SER,FLARE, AMBER	EZ1201A
ACC,MODULE,LED,12+ SER,FLARE,BLUE	EZ1201B
ACC,MODULE,LED,12+ SER,FLARE, RED	EZ1201R
ACC,MODULE,LED,12+ SER,FLARE, GREEN	EZ1201G
ACC,MODULE,LED,12+ SER,FLARE, WHITE	EZ1201W
LED,ALLEYWORKLIGHT,12+ SERIES	EZ1204
LED,STI,12+ SERIES	EZ1202AR
LED,STT,12+ SERIES	EZ1205
<b>Cables</b>	
ACCESSORY,CABLE,CONTROL, 15'	EZ0008
CONTROLLER CABLE - 8'	EZ1413
CONTROLLER CABLE - 48'	EZ1413-48
<b>Touch Pad</b>	
CONTROLLER,TOUCHPAD,12+ SERIES	EZ1202
ACCESSORY IN-CAB CONTROLLER	EZ0006
<b>JBOX</b>	
J-BOX,12+SERIES,DISCRETE WIRE CONTROL	EZ1207
<b>Mounting</b>	
REPLACEMENT,FOOT,PAIR	ER0002
ACCESSORY,RACK MOUNT KIT,10 15 20 30 SER	A1032RMK

## Troubleshooting:

All lightbars are thoroughly tested prior to shipment. However, should you encounter a problem during installation or during the life of the product, follow the guide below for troubleshooting and repair information. If the problem cannot be rectified using the solutions given below, additional information may be obtained from the manufacturer – contact details are at the end of this document.

### LIGHTBAR AND CONTROLLER

<b>PROBLEM</b>	<b>POSSIBLE CAUSE</b>	<b>SOLUTION</b>
Does not function	Poor power or ground connection	If controller functions normally, or if a 12/24V control voltage is present on either the Pattern 1 (brown) or Pattern 2 (orange) wires, then replace the driver board in the lightbar. If controller does not function, then check fuse, cables, and connections to the lightbar and to the controller.
	Blown fuse	Check wiring, replace fuse
One or two LED head do not flash, but Pattern 1 or Pattern 2 indicator LED on control module is on.	Open circuit wiring from control module to LED head	Connect a known-good LED head to the problem output to ensure the control module is working correctly. Repair or replace.
	Failed LED head	Replace LED head
LED head flashes dimly	Defective head or driver board	Check correct LED head
Incorrect flash patterns	Wrong flash configuration	Re-program the lightbar flash pattern for either Program 1 or Program 2, or both.
Secondary pattern does not function	Normal operation	Primary function overrides secondary function – turn off primary function

### ALLEY / TAKEDOWN / WORKLIGHTS

<b>PROBLEM</b>	<b>POSSIBLE CAUSE</b>	<b>SOLUTION</b>
Light does not function	Defective light	Replace light
	Defective controller	If indicator LED on controller is lit, then it is either the light, or the cable to the light, or the driver board. Otherwise the controller is defective.

### STOP/TAIL/TURN

<b>PROBLEM</b>	<b>POSSIBLE CAUSE</b>	<b>SOLUTION</b>
Both/all lights do not function	Blown fuse	Check wiring, replace fuse
	No power	Check to see if vehicle S/T/T lights function properly
	Failed S/T/T LED head	Make sure that the S/T/T head is plugged into the S/T/T control board and not the driver board. Replace S/T/T LED head and/or its cable.