

---

# **DYNATRAC**

**THE PERFORMANCE AXLE SPECIALIST**

2003-2008 4X4 Dodge 2500/3500 [Heavy Duty Ball Joint Kit](#)

## ProSteer Ball Joint Installation V2.0

 **WARNING:** This product is designed for use in specified axles and should not be used for custom applications. Any non approved application will risk your safety and the safety of others around you. Any non approved use will void the warranty of the product.

 **WARNING:** Improper use or installation of this product can cause major failures that could lead to injury or death.

 **WARNING:** Do not use Dynatrac Lower ball joint with use of a camber adjusted upper ball joint.

 **WARNING:** There are knock off axle products that are not made to AAM specifications. Dynatrac will not be accountable for the tolerances of non AAM products on the market.

 **INFORMATION:** Dynatrac ball joints are sold in a fully assembled condition, ready to install in your vehicle. Install the ball joints as if they are standard OEM replacement parts. Refer to your vehicle or axle service manual or contact a competent auto repair or alignment shop to properly install the ball joints on your vehicle. Press tools are required when installing ball joints, and it is recommended that you use the listed tools or a competent shop.

For the do it yourself guy, Dynatrac recommends using Miller Press Kit 8975 in conjunction with kit CR9.2-1X3050-C supplied by Dynatrac (Fig 11). Other ball joint installation kits besides the listed Miller kit are available; however Dynatrac has not tested them.

**Note:** Dynatrac strongly recommends buying the Dynatrac ball joint installation kit sold separately. The Dynatrac ball joint installation kit will prevent damage to the ball joints during installation.

### **Common Tools Which Will be Required**

- Ball Joint Press Kit, Or Shop Press Equipment (Miller Kit – 8975)
    - Miller Tool Kit Should be Used With the Dynatrac Kit Sold Separately
    - C-Clamp (Miller C-4212F)
    - Press Tools (Miller, 8975-1, 8975-2, 8975-3, 8975-4, 8975-5, 6289-3)
    - May have to order Miller tool # 6289-3 separate from kit # 8975
  - Dynatrac Ball Joint Installation Kit CR9.2-1X3050-B (For use with any installation kit)
  - 1-1/8 Socket
-

- 
- 15/16 Socket
  - Calibrated Torque Wrench
  - Pry Bar
  - Wire Brush
  - 4 Quarts of Gear Oil (Optional)

## Installation Instructions

 **WARNING: Only perform this installation if you are an experienced, fully equipped mechanic.**

 **WARNING: Always wear proper safety equipment including safety glasses and gloves while working with tools. Improper use of tools and equipment can cause injury or death.**

### Preparation and Inspection

1. As stated above only perform the installation if you are a fully equipped mechanic. Using the attached bill of materials, verify the kit is complete (Figure 10). You may need anywhere between 4 to 10 hours depending on your experience, so allow plenty of time. If you are performing the installation at home, Dynatrac strongly recommends using the miller ball joint kit with the Dynatrac kit. Dynatrac also recommends using kit number CR9.2-1X3050-B with all other installation kits.

### Removing the Knuckle

2. Because there are multiple axle configurations, it is recommended a service manual specific to the vehicle is used. Publications are available online that offer detailed instructions for replacing ball joints and disassembling the wheel end.
3. Remove the wheel hub assembly, brakes, tie rod and all other miscellaneous hardware as outlined in the service manual. Once the knuckle is exposed, loosen the two nuts located on the shaft of the upper and lower ball joint. Loosen the lower ball joint nut until 3-5 threads are still on the nut, this will prevent the knuckle from falling off. Since the ball joints have a tapered stud they will be firmly seated in the knuckle. To remove the ball joint stud from the knuckle, use a 5Lb metal hammer to hit the bottom of the end forging. Several hard well directed blows should cause the ball joint stud to fall out of the end forging. At this point you will have the end forging with the ball joints still pressed inside of them (Figure 1).



Figure 1, End Forging With OEM ball joints

---

---

## Pressing Out Ball Joints

### Removing the Upper Ball Joint

4. At this point the old ball joints may be pressed out of the end forging. Using the ball joint press kit remove the upper ball joint first (Miller Tools, C-4212F, 8975-2, 6289-3). Use tool 6289-3 to push the ball joint and 8975-2 to receive the ball joint (Figure 2).

### Removing the Lower Ball Joint

5. After the upper ball joints have been removed the lower ball joints may be pressed out using the kit (Miller Tools, C-4212F, 8972-2, 6289-3). Use tool 6289-3 to push the ball joint and 8975-2 to receive the ball joint (Figure 3).



Figure 2, Pressing out Upper Ball Joint



Figure 3, Pressing out OEM Lower Ball Joint

### Prepping the Ball Joint Bores

6. Once all of the ball joints have been removed use brake cleaner or another solvent to clean the bores in the knuckle and end forging. It is extremely important to clean any rust or sediment build up off of the end forging faces where the ball joints will seat. This can be done using a wire wheel, Scotch-Bride or 100 grit sand paper. Cleaning of the end forging bores is extremely important to make sure the ball joints seat correctly.
-

---

## Installing Dynatrac Ball Joints

 **WARNING:** Shop presses exert tremendous force and can easily damage components if caution is not exercised.

 **WARNING:** Pressing on the seal when installing the lower ball joint will damage the seal. Exercise great caution when installing the ball joints to reduce the risk of damage.

**Note:** Dynatrac strongly recommends using the Miller tool kit in conjunction with the Dynatrac Ball Joint installation kit.

### Preparation

7. After the knuckles and end forgings have been cleaned, place Anti-Seize on all the ball joint bodies (Figure 4). There is a significant amount of force required to install the ball joints. Anti-Seize will help prevent galling and damage to the axle components when installed.



Figure 4, Applying Anti-Seize to ProSteer Body

### **Tools Needed**

- Miller tools (C-4212F, 8975-5, 8975-3, 8975-1)
- Dynatrac Tool Kit
- Socket and Wrench for C-Clamp

### Installation of Lower Ball Joint

---

---

**Note: Only press on the rim of the ball joint, do not press on the seal or it will damage the parts (Fig 6).**

8. Start by installing the lower ball joint first with the press tools using tools C-4212F, 8975-3, 8975-1 and DA60-3050-N (Figure 5). Make sure the flange on the ball joint is full seated on the end forging. Place the snap ring back on the lower ball joint after they have been pressed into place. Repeat the procedure for the opposite side.

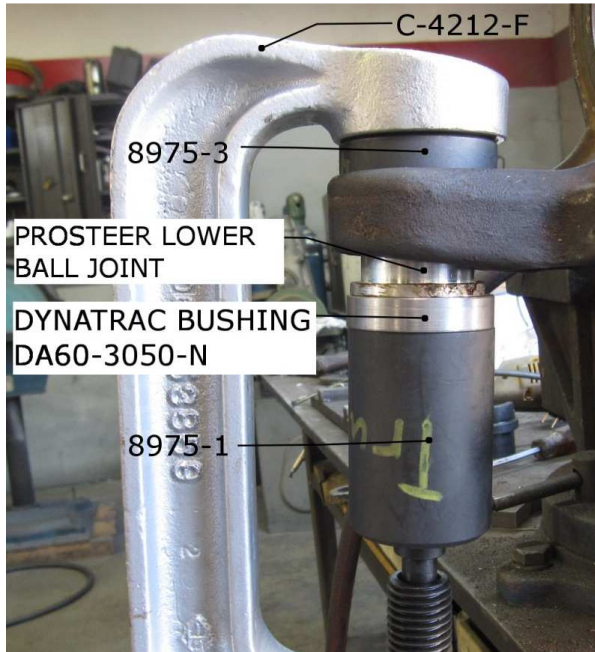

(Figure 5, Pressing In ProSteer Upper Ball Joint)

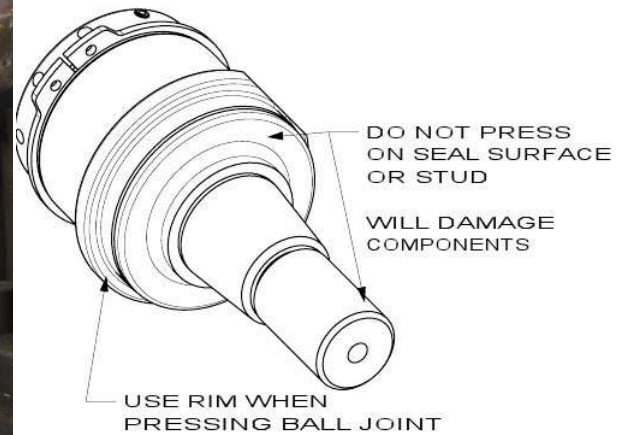

(Figure 6, Proper Press Location)

### **Installation of Upper Ball Joint**

9. After the lower ball joint is installed the upper ball joints may be installed. With a screw driver pry the E-Clip off of the upper ball joint (Figure 7). Use Miller tool C-4212F, 8975-5, 8975-1, DA60-3050-N & CR9.2-3049-K to install the upper ball joint (Figure 8). Make sure the ball joint is fully seated on the end forging. After the ball joint has been installed place the E-Clip back on the upper ball joint. Repeat the procedure for the opposite side.
-

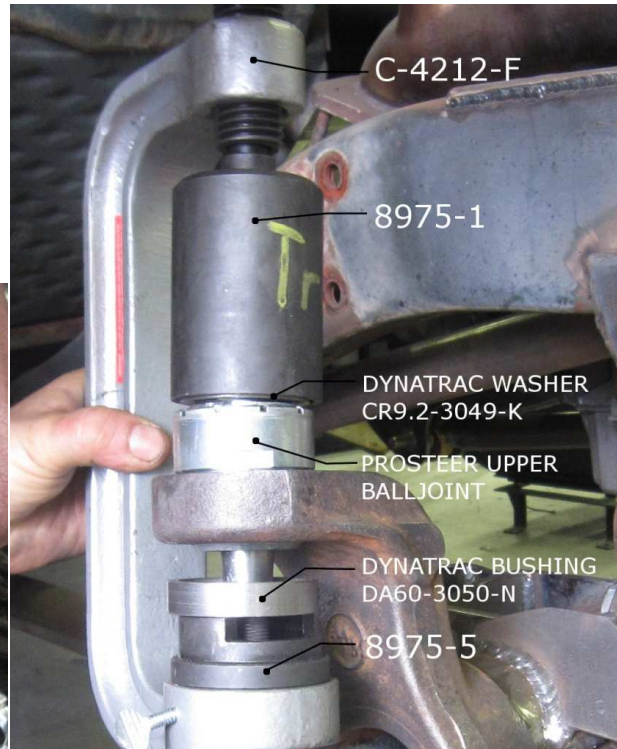

(Figure 7, Removing E-Clip Form ProSteer Upper Ball Joint) (Figure 8, Installing ProSteer Upper Ball Joint)

### **Installation of Knuckle**

10. Now the knuckle is ready for installation. A 1-1/8 socket and a 15/16 socket are required to tighten the ball joint nuts. Be sure to clean the tapered shafts with brake cleaner or acetone; this will help prevent the shaft from spinning during assembly. Place the knuckle into the end forging and lightly screw on the ball joint nuts, preventing the knuckle from sliding out.
11. Once the knuckle has been lightly fastened to the end forging begin to tighten the upper ball joint. The upper ball joint has a shaft that plunges. Use the upper ball joint nut to pull the upper ball joint shaft into the knuckle. This will pull the lower ball joint into the bottom of the knuckle. After the upper ball joint nut has been lightly tightened the lower ball joint nut can be tightened.

### **Torque Procedure**

- Torque upper ball joint to 35ft. lbs
- Torque lower ball joint to 70 ft. lbs,
- Torque upper ball joint to 70Ft/ lbs, then rotate the castle nut to the next available slot
- Insert cotter pin and fold the tab over
- Re-torque lower ball joint to 140/160 ft. lbs

### **Reassembly of Wheel end**

12. At this point the knuckle should be properly bolted to the end forging. Refer to the service manual and reassemble the wheel end. After everything has been installed check the wheel alignment. Make sure

the axle is filled with gear oil if the differential was drained prior to disassembly. The knuckle may feel stiff as you move it from side to side; this is common and nothing to worry about.

**⚠ WARNING: Failure to properly refill the axle with Gear Oil can cause serious gear and bearing failure which could result in serious injury or death.**

**⚠ WARNING: Failure to check bolt and lug nut torque can cause serious accident, component failure, serious injury or death.**

**Bill of Materials**

2003-2008 Dodge ProSteer Ball Joint		
CR92-2X3051-A		
Description	Quantity	Dynatrac P/N
Body Snap Ring	2	CR9.2-3050-F
Upper Ball Joint	2	CR9.2-1X3049-A
Lower Ball Joint	2	CR9.2-1X3050-A
5/8-18 Castle Nut	2	CR9.2-3049-E
Cotter Pin	2	CR9.2-3049-F
Lock Nut	2	CR9.2-3050-D

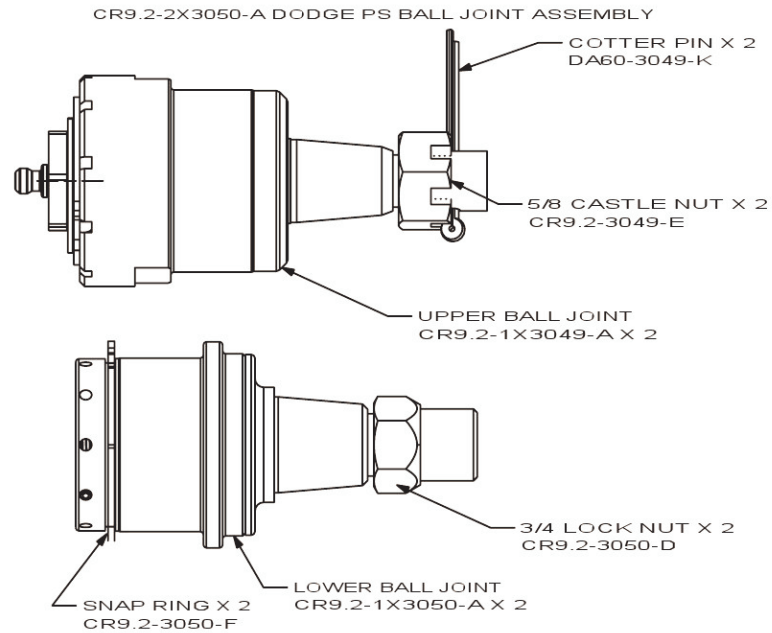

Figure 9, Dodge ProSteer BOM

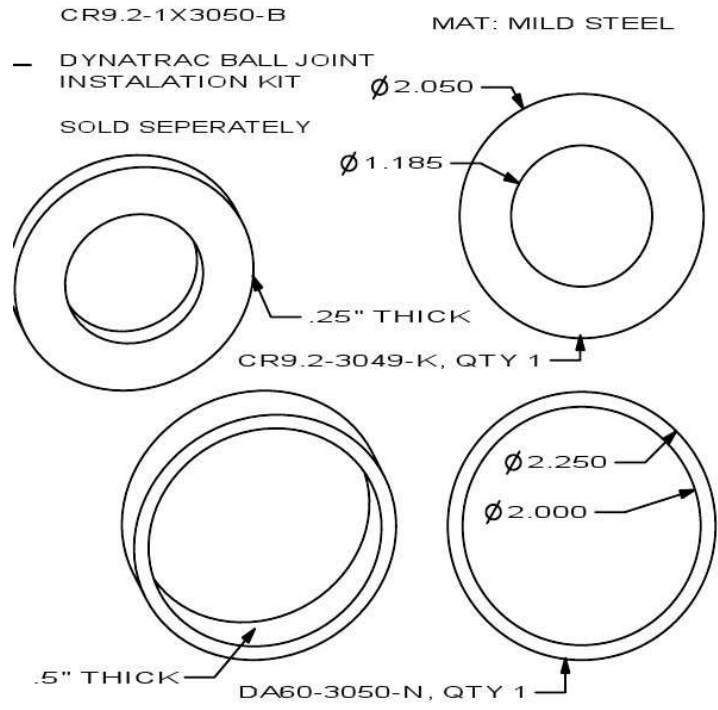

Figure 10, ProSteer Additional Installation Kit