

DLx PULLING WINCHES



Model #DLx1200FC



DLx1200
DLx1200FC
DLx1500
DLx1500FC

DLx1900
DLx1900FC
DLx2300
DLx2300FC
DLx2600FC



**MADE IN
USA**



WARNING READ INSTRUCTIONS CAREFULLY BEFORE ATTEMPTING TO INSTALL, OPERATE OR SERVICE THIS WINCH. FAILURE TO COMPLY WITH INSTRUCTIONS COULD RESULT IN SERIOUS OR FATAL INJURY. RETAIN THESE INSTRUCTIONS FOR FUTURE REFERENCE.



IMPORTANT SAFETY INFORMATION

- This winch is built for multi-purpose hauling and pulling operations. It is not recommended for lifting applications. For lifting, use a self-locking winch. DLx winches are not to be used as hoists for lifting, supporting or transporting people or for loads over areas where people could be present.
- Respect this winch. High forces are created when using a winch, creating potential safety hazards. It should be operated and maintained in accordance with instructions. Never allow children or anyone who is not familiar with the operation of the winch to use it.
- Maintain a firm grip on the winch handle at all times, and never release the handle when ratchet lever is in unlocked position with a load on the winch. Otherwise, handle will spin violently, which could cause personal injury.
- Check for proper ratchet operation on each use of the winch. Do not use if damaged. Seek immediate repairs.
- Never use the winch handle as a convenient handle for pulling or maneuvering the entire trailer or other equipment. Never pull on the winch handle against a locked ratchet.
- Never exceed rated capacity. Excess load may cause premature failure and could result in serious personal injury. This winch is rated with three layers of line on the hub. Using more layers of line or a large hub increases the load on the winch.
- Never apply load on winch with line fully extended. Keep at least three full turns of line on the reel.
- Secure load properly. When winching operation is complete, do not depend on winch to support load.
- Operate with hand power only. This winch should not be operated with a motor of any kind. If the winch cannot be cranked easily with one hand, it is probably over-loaded.

WINCH MOUNTING AND CABLE ATTACHMENT

For maximum strength and safety, (and compliance with SAE Standard J1853) this winch should be mounted with three 3/8" or M10 bolts, washers, and lock washers.

Select a winch line with breaking strength at least 1-1/2 times the winch rating and a hook 1-1/2 times stronger than the line. If steel cable is selected, the optional reel with large hub may extend cable life. (The above combination meets SAE Standard J1853 for boat trailer winches).

Attach cable or rope by either method described in sketch. If nylon strap is used, it should have a loop sewn in one end and be attached using a 3/8" x 3" long bolt and locknut. Use a locknut, not a nut and lock washer. Insert bolt through slots in both reel side plates so that nut is on gear side. Tighten only until snug with bolt in bottom of slot next to reel hub.

To mount the winch, the top cover will need to be removed from the winch. To install cable or strap, the top cover and sides will need to be removed. See winch cover removal and assembly section for instructions.

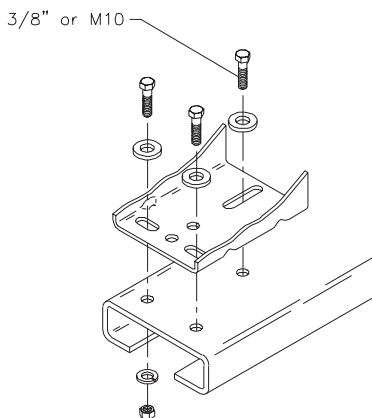

CABLE ATTACHMENT METHODS (IF CABLE IS USED)

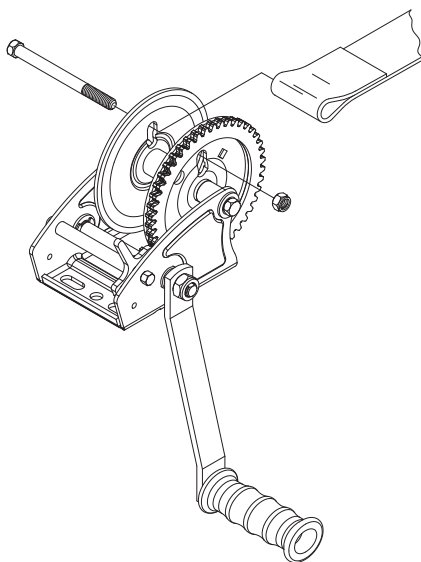
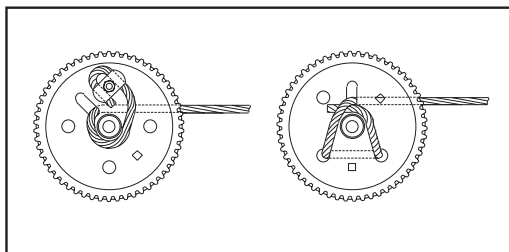

MAXIMUM STRAP ANGLE

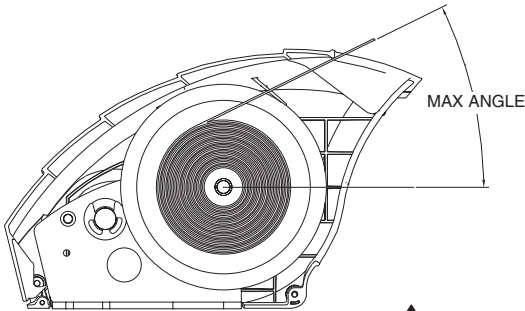

DLx1200FC - 15 Ft. Strap - 29°
DLx1500FC - 20 Ft. Strap - 25°
DLx1900FC - 20 Ft. Strap - 26°
DLx2300FC - 25 Ft. Strap - 24°
DLx2600FC - 25 Ft. Strap - 26°



CAUTION: Exceeding the maximum strap angle could result in damage to winch cover.

OPERATING INSTRUCTIONS DLx1200, DLx1500 & DLx1900

HANDLE AND NUT MUST BE TIGHTENED AGAINST DRIVE SHAFT BEFORE OPERATING WINCH. Wind line on winch reel by turning winch handle in clockwise direction with ratchet lever in up position. The ratchet should produce a loud, sharp clicking noise. Make sure that ratchet lever is in up position and holding load before winch handle is released. To unwind or reel out line, securely grip winch handle and apply force in clockwise direction so that ratchet lever can easily be moved to down position. Carefully turn handle in counterclockwise direction. Do not lose control.

The winch can be converted to wind line on to the underside of the reel. To do this, carefully examine ratchet assembly and remove it from winch. Do not lose small parts. Turn the lever over and reassemble. Do not over tighten bolt. Check operation to insure the ratchet lever rotates fully without binding.

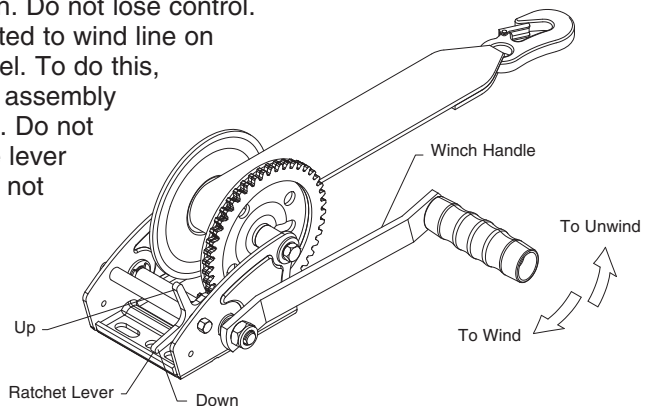

OPERATING INSTRUCTIONS

DLx2300

HANDLE AND NUT MUST BE TIGHTENED AGAINST DRIVE SHAFT BEFORE OPERATING WINCH. Wind line on winch reel by turning winch handle in counter-clockwise direction with ratchet lever in down position. The ratchet should produce a loud, sharp clicking noise. Make sure that ratchet lever is in down position and holding load before winch handle is released. To unwind or reel out line, securely grip winch handle and apply force in counter-clockwise direction so that ratchet lever can easily be moved to up position. Carefully turn handle in clockwise direction. Do not lose control. The winch can be converted to wind line on to the underside of the reel. To do this, carefully examine ratchet assembly and remove it from winch. Do not lose small parts. Turn the lever over and reassemble. Do not over tighten bolt. Check operation to insure the ratchet lever rotates fully without binding.

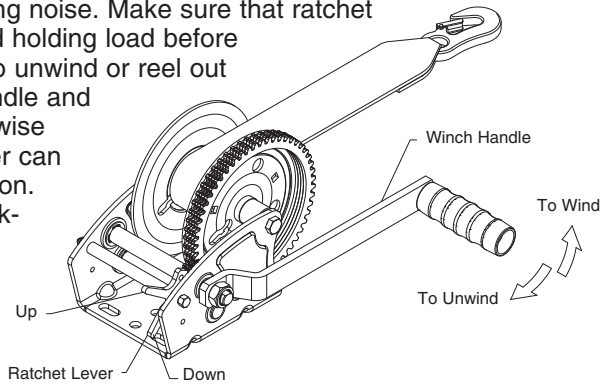

OPERATING INSTRUCTIONS

DLx2600

Attach winch handle securely to primary drive shaft (upper or low speed shaft). Make sure that handle clip engages with groove in drive shaft. Wind line on winch reel by turning winch handle in counterclockwise direction with ratchet lever in "down" position. The ratchet should produce a loud, sharp, clicking noise. Make sure that ratchet lever is in "down" position and holding load before winch handle is released. To unwind or reel out line, securely grip winch handle and apply force in counterclockwise direction so that ratchet lever can easily be moved to "up" position. Carefully turn handle in clockwise direction. Do not lose control. If handle is attached to intermediate (lower or high speed) shaft, operate as described above, reversing clockwise and counterclockwise. The winch can be converted to wind line on to the underside of the reel. To do this, carefully examine ratchet assembly and remove it from winch. Do not lose small parts. Turn the lever over and reassembly. Do not over tighten bolt. Check operation to insure the ratchet lever rotates fully without binding.

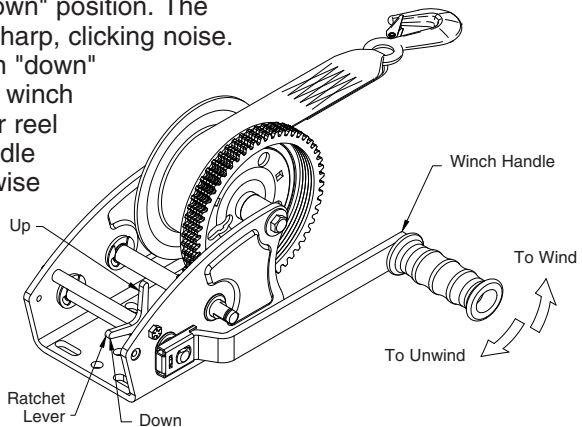

NOT FOR THE MOVEMENT OF HUMAN BEINGS

WINCH MAINTENANCE

This winch has been fully lubricated at the factory; but, for continued smooth performance and increased life, occasional greasing of gears and reel shaft and an occasional drop of oil on drive shaft bearings are recommended. Keep winch in good working order. Damaged or severely-worn parts create unnecessary dangers and could result in personal injury or property damage.

DLx1200 & DLx1500

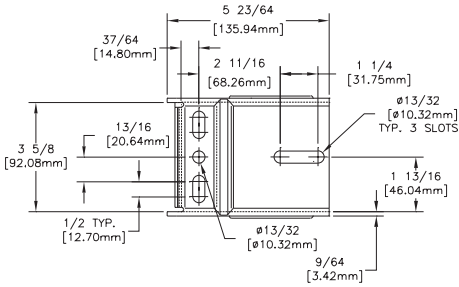

DLx1900 & DLx2300

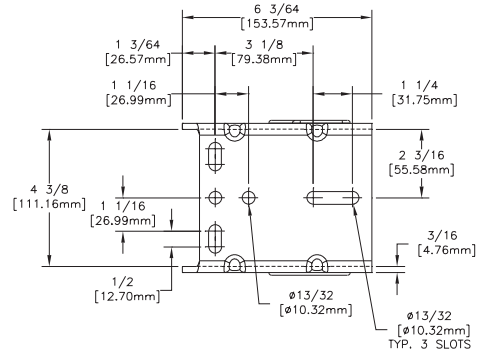

DLx2600

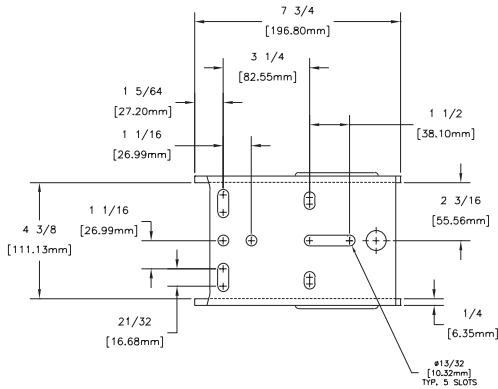

Model	Rated Capacity	Drum Hub Dia.	Gear Ratio	Handle Length	Max Mech. Adv.	Maximum Drum Capacity	
						Cable	Strap
DLx1200	1200 lb/544 kg	7/8"	4.4:1	7"	56	7/32" x 56'	31'
DLx1500	1500 lb/680 kg	7/8"	4.4:1	9-1/2"	74	1/4" x 40'	31'
DLx1900	1900 lb/862 kg	1-1/8"	5.4:1	9-1/2"	73	9/32" x 49'	38'
DLx2300	2300 lb/1043 kg	1-1/8"	7.2:1	9-1/2"	95	5/16" x 39'	38'
DLx2600	2600 lb/1179 kg	1-1/8"	17.3:1 /5.4:1	9-1/2"	226	5/16" x 47'	38'

WINCH COVER REMOVAL AND ASSEMBLY

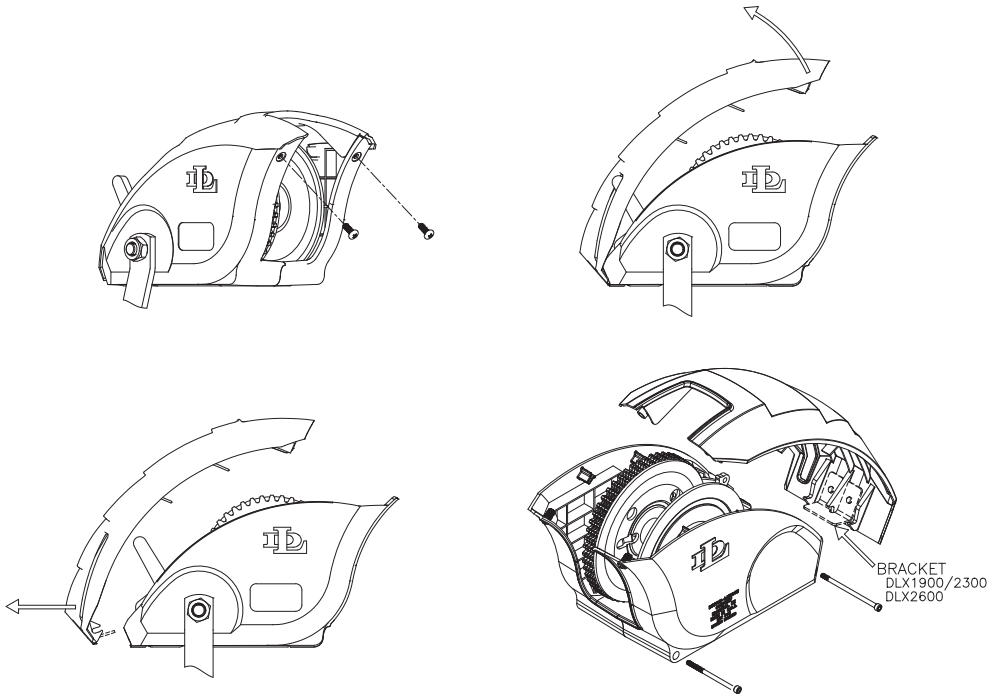

The cover comes off the winch in three pieces. To remove the top cover, loosen and remove the top phillips screws in the front of the cover with a screwdriver. Pull up on the front of the top cover and rotate the top away from the winch. Once the locking tabs are disengaged from the sides, pull the cover straight back to remove.

To remove the cover sides, use a 9/64 hex key to remove the two socket head screws in the bottom front and back on the winch side. Once the screws are removed, pull the cover sides away from the winch to remove.

To reassemble the winch cover, slide the two sides into place around the winch. Use a 9/64 hex key to install the two socket head screws.

⚠ CAUTION: Tighten cover screws by hand only. Over-tightening could make top cover difficult to install or damage winch cover.

With the sides in place and bolts installed, place the tabs on the back of the top cover around the bolt on the back of the winch. Rotate the top cover back onto the winch and press on the middle of the top until the locking tabs snap into the cover sides. Install the phillips screws in the front of the cover and tighten.



DLx1200 & DLx1500

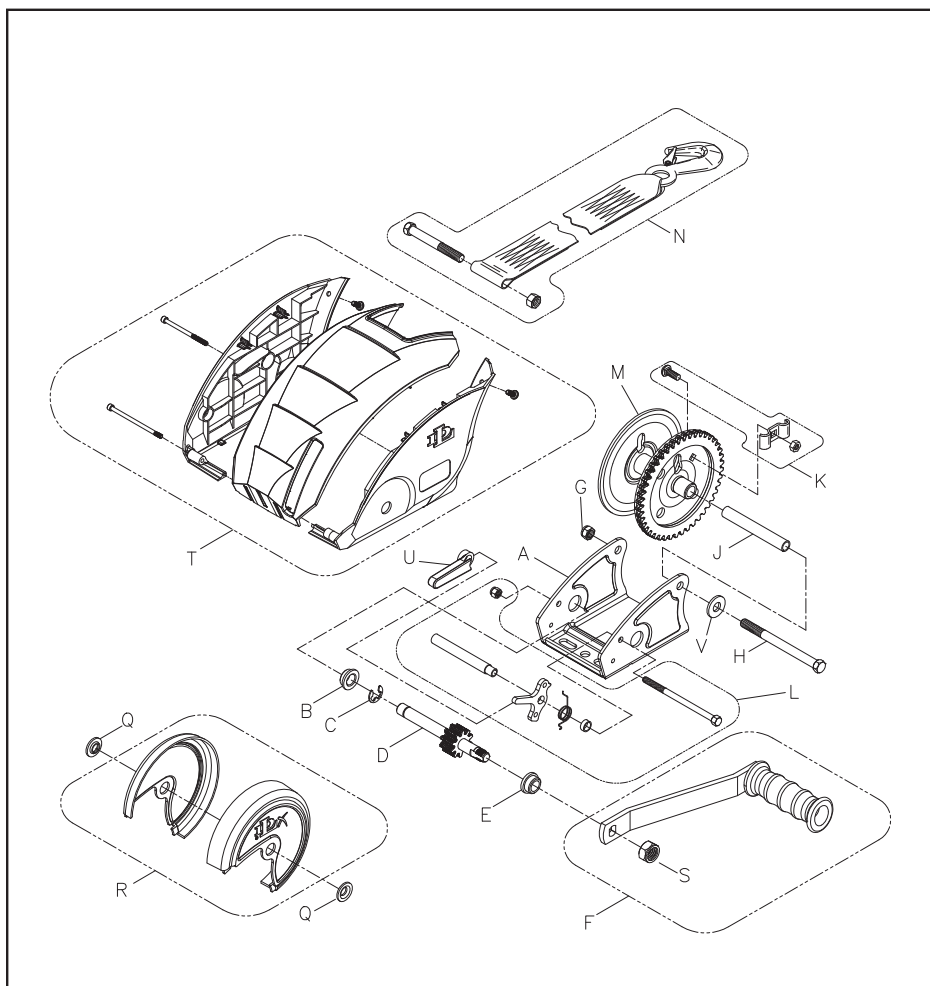

Ref.	Description	Part. No.	Ref.	Description	Part. No.
A	Base - DLx1200	406196	L	Ratchet Kit	5704556
A	Base - DLx1500	406195	M	Reel - DLx1200	304723-PL
B	Bushing	204006	M	Reel - DLx1500	306278
C	Retaining Ring	205012	N	Strap, 20 ft.	5242607
D	Drive Shaft	304722	Q	Spacer Washer	404916
E	Bushing	204007	R	Reel Cover Kit	5170030
F	DLx1200 Handle 7" - Black	5703848	S	Nut	205015
F	DLx1500 Handle 9-1/2" - Black	5703855	T	Full Cover Kit - DLx1200	5170055
G	Locknut	205270	T	Full Cover Kit - DLX1500	5170295
H	Reel Bolt	203161	U	Ratchet Pawl Cover	206766
J	Reel Spacer	204807	V	Washer	205044
K	Rope Clamp Kit (Opt.)	5243506			



DLx1900

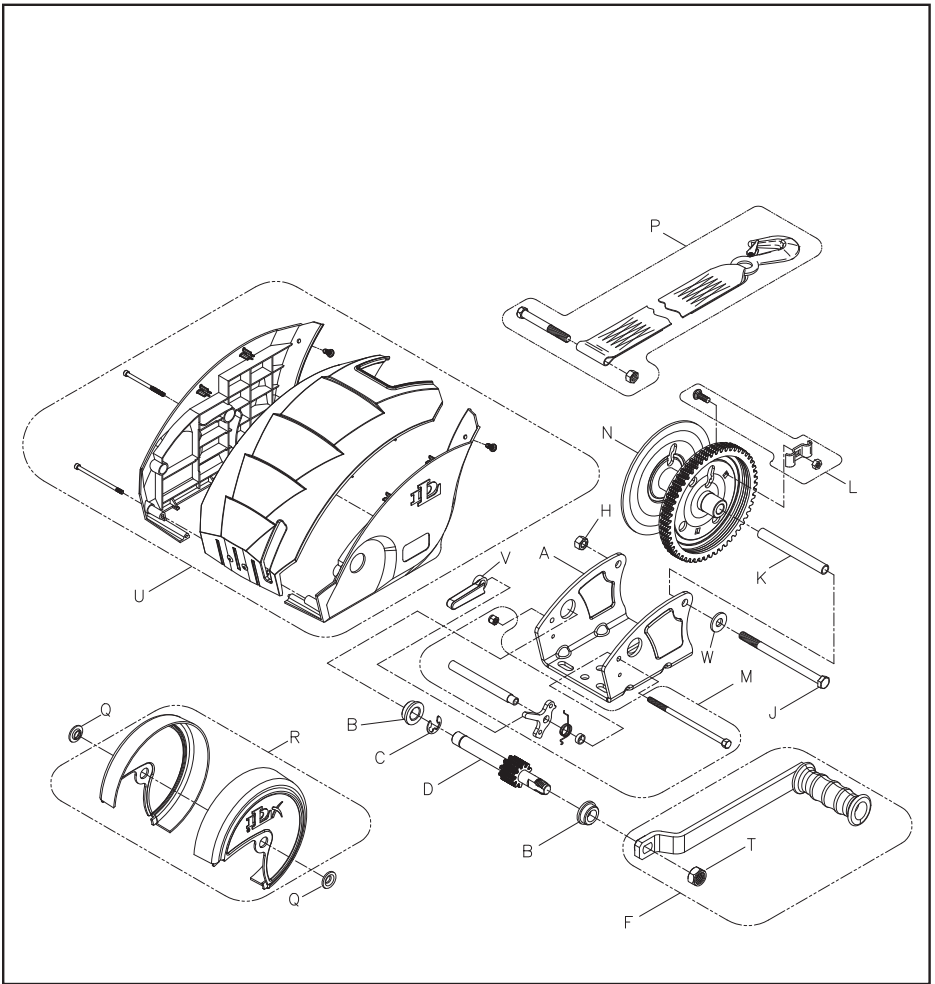

Ref.	Description	Part. No.	Ref.	Description	Part. No.
A	Base	406191	N	Reel	304779-PL
B	Bushing	204009	N	Large Hub Reel	306124
C	Retaining Ring	205116	P	Strap, 20 Ft.	5242409
D	Drive Shaft	304731	Q	Spacer Washer	404916
F	Handle 9-1/2" Black	5703863	R	Gear Cover Kit	5170451
H	Locknut	205270	T	Nut	204809
J	Reel Bolt	204804	U	Full Cover Kit	5170477
K	Spacer	204808	V	Ratchet Pawl Cover	206766
L	Rope Clamp Kit (Opt.)	5243506	W	Washer	205044
M	Ratchet Kit	5704754			



DLx2300

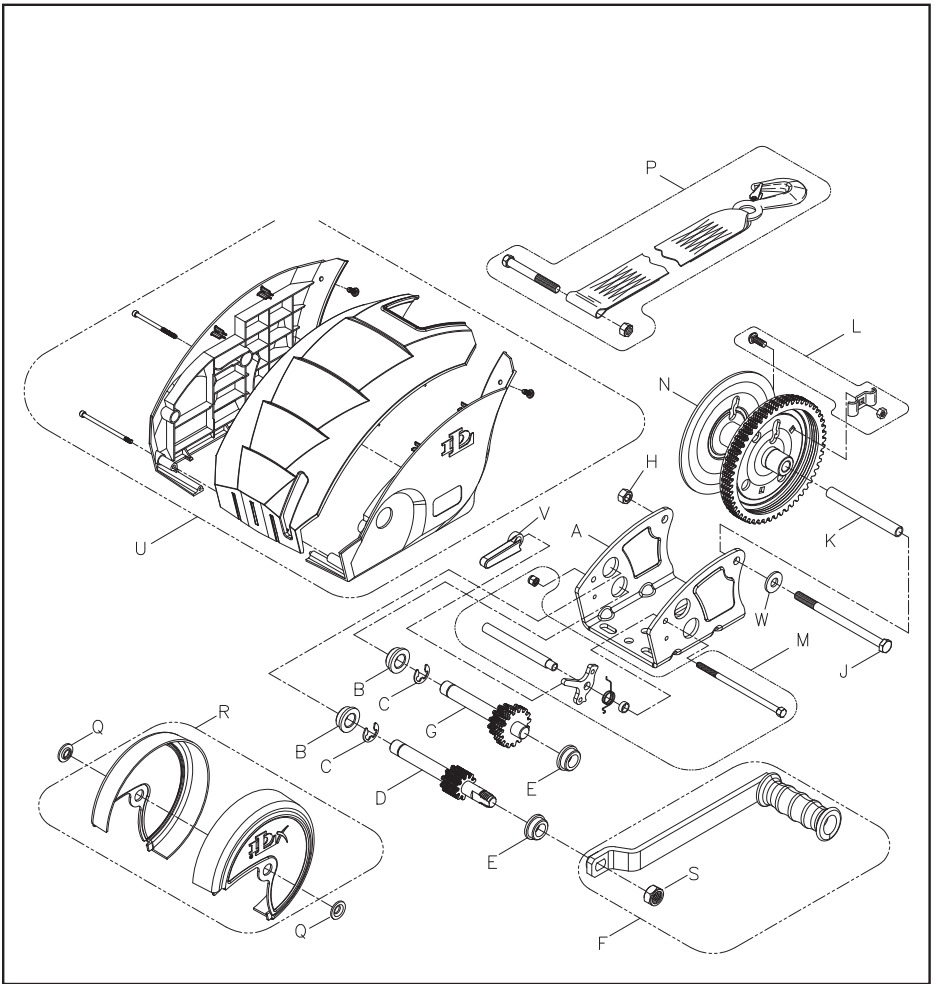

Ref.	Description	Part. No.	Ref.	Description	Part. No.
A	Base - DLx2300	406192	M	Ratchet Kit	5704754
B	Bushing	204009	N	Reel	304779-PL
C	Retaining Ring	205116	N	Large Hub Reel	306124
D	Primary Shaft	306258	P	Strap, 25 Ft.	5242482
E	Bushing	204012	Q	Spacer Washer	404916
F	Handle 9-1/2" - Black	5703863	R	Gear Cover Kit	5170451
G	Intermediate Shaft	306259	S	Nut	204809
H	Locknut	205270	U	Full Cover Kit	5170683
J	Reel Bolt	205335	V	Ratchet Pawl Cover	206766
K	Reel Spacer	204808	W	Washer	205044
L	Rope Clamp Kit (Opt.)	5243506			



DLx2600

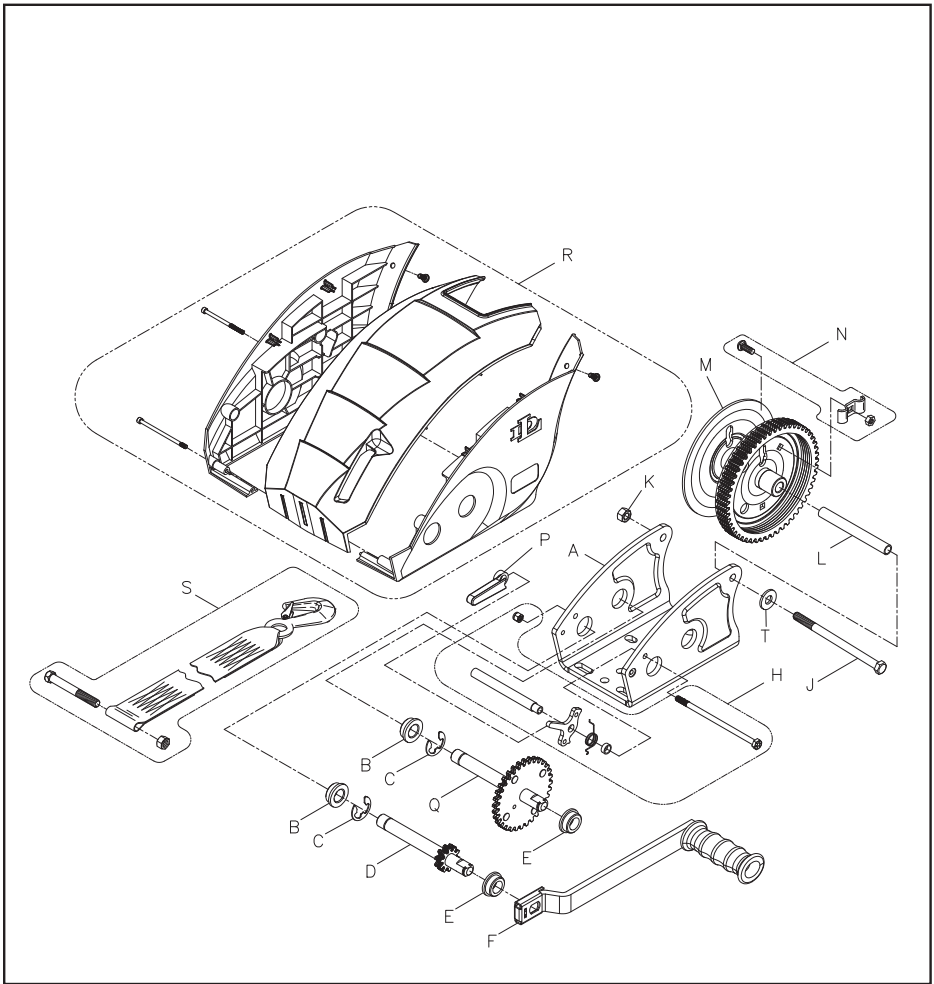

Ref.	Description	Part. No.	Ref.	Description	Part. No.
A	Base	406220	L	Reel Spacer	204808
B	Bushing	204009	M	Reel	304782-PL
C	Retaining Ring	205116	N	Rope Clamp Kit	5243506
D	Primary Shaft	304726	P	Ratchet Pawl Cover	206766
E	Bushing	204012	Q	Intermediate Drive Shaft	304727
F	Handle 9-1/2" - Black	306322-BPL	R	Full Cover Kit	5170873
H	Ratchet Kit	5704754	S	Strap, 25 Ft.	5242482
J	Reel Bolt	204804	T	Washer	205044
K	Lock Nut	204803			

Discover other winches and accessories on our website.