

BRAKE WINCHES

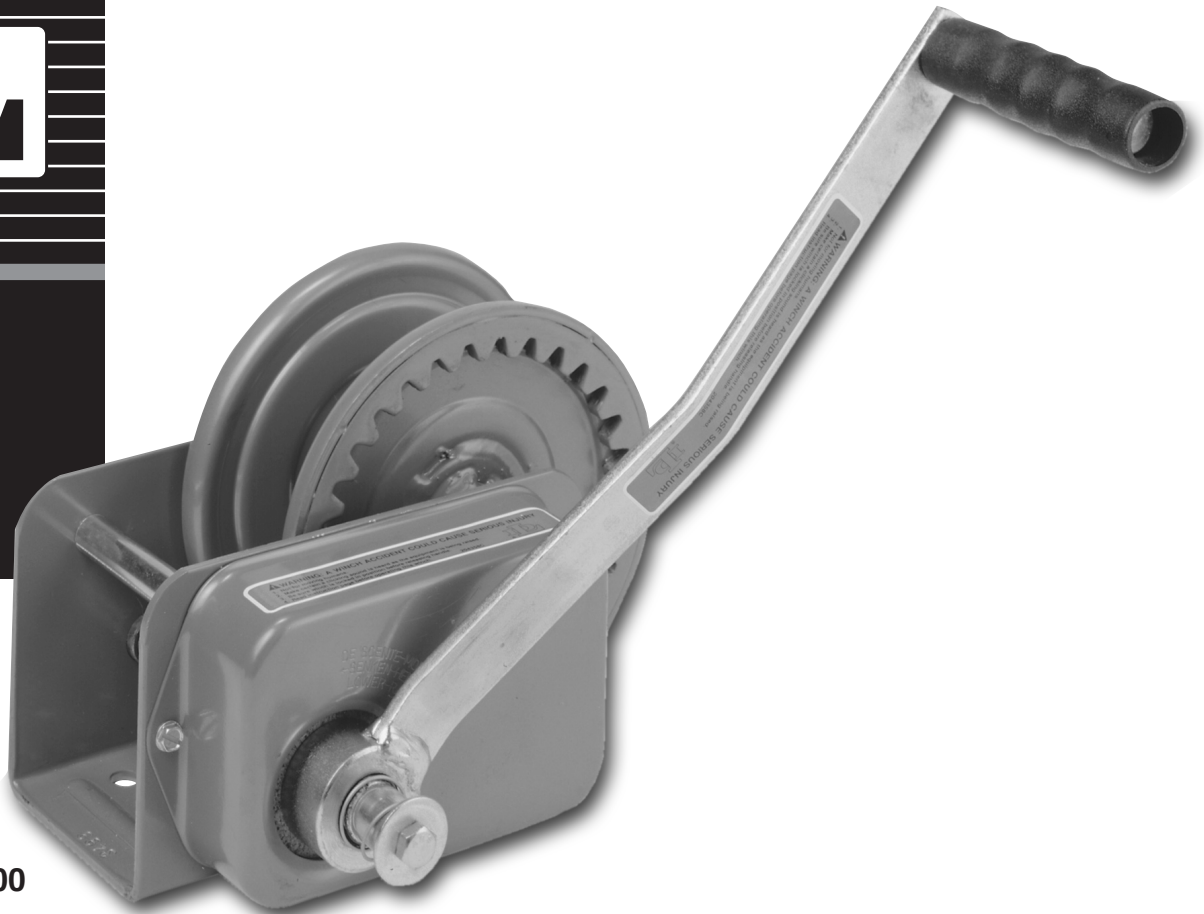

B1500

B1200B

B2500

B1200G

B2500G

B1500

B3500

B1500G



**MADE IN
USA**

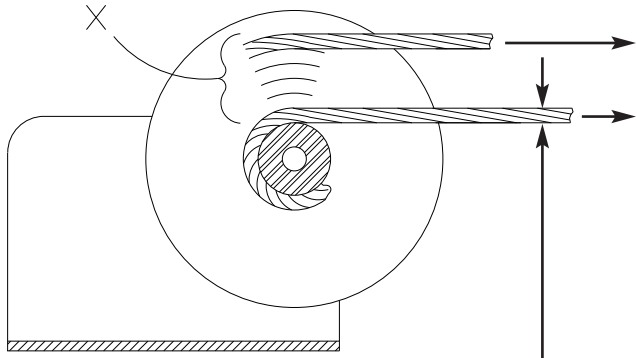

	"X"	
B1200B, B1200G	6 1	650 lb/295 kg 1200 lb/545 kg
B1500, B1500G	6 1	728 lb/330 kg 1500 lb/680 kg
B2500, B2500G	3 1	1554 lb/705 kg 2500 lb/1135 kg
B3500	3 1	2172 lb/985 kg 3500 lb/1590 kg

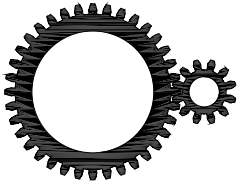

B1200B B1200G	4:1
B1500 B1500G	6:1
B2500 B2500G	12:1
B3500	18.75:1

B1200B	7/32" (5600 lb) x 57'
B1200G	5mm (1640 kg) x 12.3m
B1500	1/4" (7000 lb) x 52'
B1500G	6mm (2040 kg) x 11.4m
B2500	5/16" (9800 lb) x 51'
B2500G	8mm (3410 kg) x 7.4m
B3500	3/8" (14400 lb) x 28'

Original Instructions



WARNING READ INSTRUCTIONS CAREFULLY BEFORE ATTEMPTING TO INSTALL, OPERATE OR SERVICE THIS WINCH. FAILURE TO COMPLY WITH INSTRUCTIONS COULD RESULT IN SERIOUS OR FATAL INJURY. RETAIN THESE INSTRUCTIONS FOR FUTURE REFERENCE.



IMPORTANT SAFETY INFORMATION

- This brake winch is built for multi-purpose hauling and lifting operations. It is not to be used as a hoist for lifting, supporting or transporting people, or for loads over areas where people could be present.
- Respect this winch. High forces are created when using a winch, creating potential safety hazards. It should be operated and maintained in accordance with instructions. Never allow children or anyone who is not familiar with the operation of the winch to use it. A winch accident could result in personal injury.
- Check winch for proper operation on each use. Do not use if damaged. Seek immediate repairs.
- Never exceed rated capacity. Excess load may cause premature failure and could result in serious personal injury. This winch is rated

- on third layer of cable on drum with drum size of 1-5/16" or less. It is rated on first layer of cable on drum with drum size of 2-1/2" or more. Using more layers of cable increases the load on the winch.
- Never apply load on winch with cable fully extended. Keep at least three full turns of cable on the reel. Check cable on every use. Replace at the first sign of kinks, broken wires, deformation or any other damage.
- Secure load properly. When winching operation is complete, do not depend on winch to support load.
- Operate with hand power only. This winch should not be operated with a motor of any kind. If the winch cannot be cranked easily with one hand, it is probably overloaded.

ASSEMBLY – Thread the handle onto the winch drive shaft and be certain that a clicking noise is produced when the handle is turned clockwise. Install the spring, shaft extension, washer and bolt on the end of the drive shaft as shown on parts drawing. These parts may appear to serve no function, but they provide several important fail-safe features, and should not be altered or removed.

WINCH MOUNTING AND CABLE ATTACHMENT – For maximum strength and safety, this winch should be mounted with three 3/8" bolts (M10), washers and lock washers. Use Grade 8 for 1500 lb./680 kg or greater capacity. (See parts drawing). Position winch so that cable approaches from reel end as shown.

Attach cable or rope by method described in sketch.

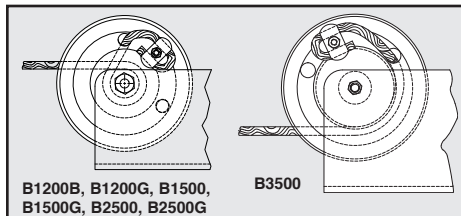

OPERATING INSTRUCTIONS – Wind cable on winch reel by turning winch handle in clockwise direction. This should produce a loud, sharp, clicking noise. The load will remain in position when the handle is released. Wind cable off the winch reel by turning winch handle counterclockwise (no noise will be produced). The load will remain in position when the handle is released, but for extra security it is recommended that the handle be turned clockwise until at least two clicks are heard. This will add extra tightness to the brake mechanism. Always satisfy yourself that the winch is holding the load before releasing the winch handle.

IMPORTANT: Sufficient load must be applied to the cable to overcome internal resistance and operate the brake properly; otherwise turning the crank handle counterclockwise will only remove the handle from the shaft – the reel will not turn. The minimum operating load requirement is 75 lbs. (34 kg) for Models B1200B & B1200G, 150 lbs. (68 kg) for B1500 & B1500G, 300 lbs. (136 kg) for B2500 & B2500G and 500 lbs. (227 kg) for B3500.

NOT FOR THE MOVEMENT OF HUMAN BEINGS

WINCH MAINTENANCE – Keep winch in good working order. Damaged or severely-worn parts create unnecessary dangers and could result in personal injury or property damage. The winch requires periodic maintenance. The following check should be made at least once annually and more frequently when the winch is exposed to an environment which is particularly dirty or wet.

1. Remove all of the load from the winch so that there is slack in the cable. Remove the winch handle and gear cover for inspection of the winch gear train and brake mechanism. This requires removal of bolt #204213 along with the flat washer, spacer and spring and requires that the handle be unthreaded (counterclockwise direction) from the drive shaft. The gear cover can then be removed.
2. Examine the winch gear train and brake mechanism for any rust, corrosion or build up of debris which might be present. Grasp the ratchet pawl #404409 and lift it out of contact with the ratchet wheel. Remove the ratchet wheel #404408 and two brake plates #205123 from the drive shaft. **IMPORTANT!** Relax the spring tension on the ratchet pawl paying particular attention to the attachment of the pawl to the spring and the amount of tension in the spring.
3. Check the entire gear train for any abnormal wear and be sure that the entire gear train turns freely. Grease all of the gear teeth with a good wheel bearing grease. Remove and grease reel bolt, reinstall reel bolt and tighten, making sure that reel shaft will not rotate in winch base.
4. Check the ratchet wheel, brake lining plates, winch handle hub and the washer on the brake winch hub ass'y for any build up or glaze (shiny spots) which may be present. This can be removed by rubbing these

parts lightly with sand paper. **CAUTION!** Do not grease or oil any of the brake mechanism parts. Check the threads on the brake winch hub ass'y and the threads in the handle hub to be sure that both are free of any rust or corrosion. Make sure that the handle runs freely onto the drive shaft thread without any binding whatsoever. Apply a small amount of grease to the threaded area to keep these parts moving freely.

5. Reassemble the two brake pads and the ratchet wheel onto the drive shaft while holding tension in the ratchet pawl. All of these parts should spin freely on the drive shaft. Be sure that the pawl properly engages with the teeth on the ratchet wheel. Thread the winch handle onto the drive shaft and check the operation of the winch. When cranking the handle in the clockwise direction, the ratchet wheel should turn with the shaft causing the pawl to snap in and out of the ratchet wheel teeth. In the counterclockwise direction the ratchet wheel should remain stationary while the handle turns.
6. Completely reassemble the winch gear cover, handle and all remaining parts. Check the mounting of the winch to be sure that it is secure and check the cable for any abnormal stiffness, kinking or broken strands. Replace the winch cable at the first sign of any damage. **NOTE:** Winch cable will last longer and remain more flexible with occasional application of light oil. The winch finish can be protected and will provide longer service if it is washed with water and then wiped with light oil or wax.

If you have any questions whatsoever concerning the above procedure, please contact the manufacturer.



B1200B & B1200G Winch

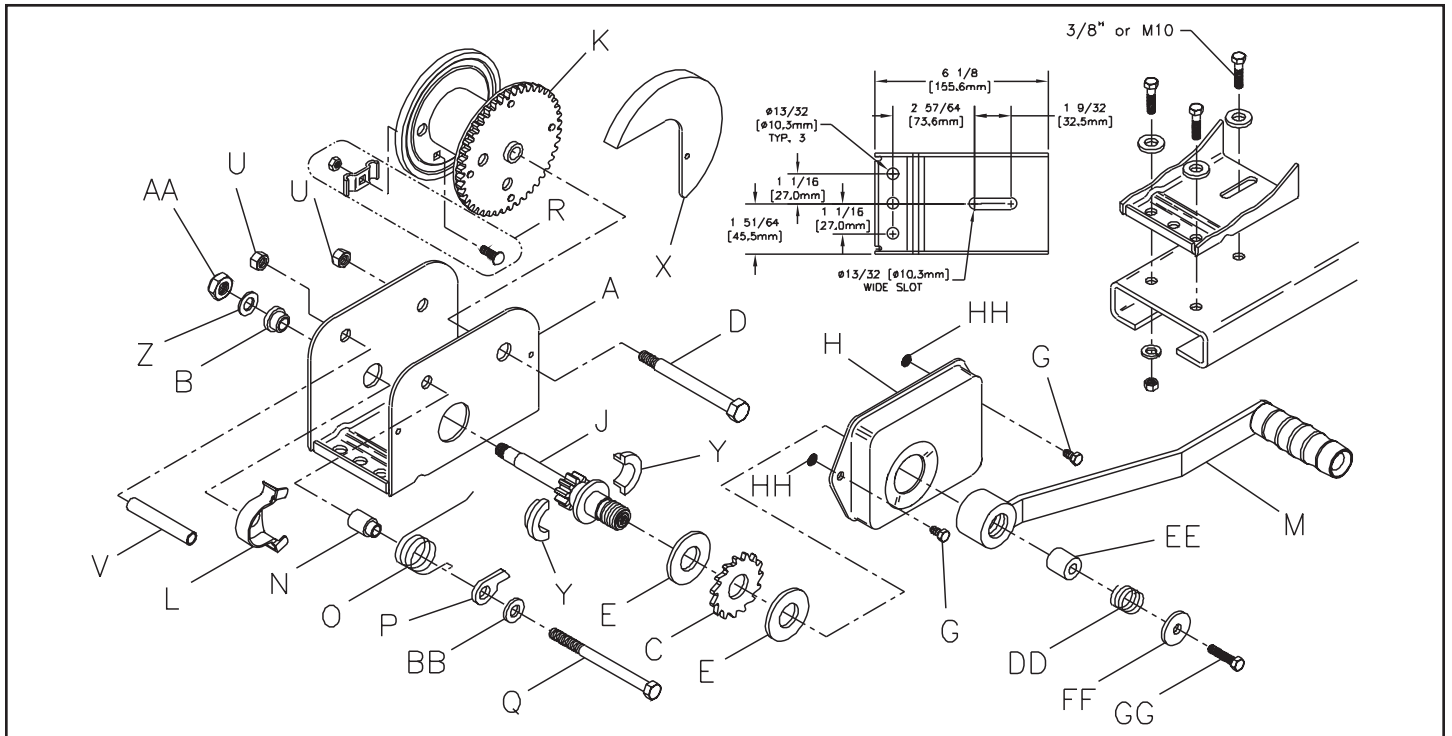

B1200B & B1200G Winch Parts List

Ref.	Description	Part No.	Ref.	Description	Part No.	Ref.	Description	Part No.
*A	Base (B1200B)	404943	M	Handle (B1200B)	5703509	V	Spacer	404371
A	Base (B1200G)	404944		w/Decal		X	Gear Cover - Opt. BZ	5240304
B	Bearing	204007	M	Handle (B1200G)	5146972	X	Gear Cover - Opt. PL	5240320
C	Ratchet Wheel	404408		w/Decal		Y	Bearing (2-Piece)	404952
D	Bolt	204805	N	Spacer	404368	Z	Washer	204360-PL
E	Pressure Plate (2)	205123	O	Spring (B1200B)	204142	AA	Locknut	205015
G	Screw (2)	205025	O	Spring (2) (B1200G)	204461	BB	Washer	205055
*H	Gear Cover	404362	P	Pawl	404409	DD	Spring	204212
J	Drive Shaft	304866	Q	Bolt	205126	EE	Shaft Extension	404122
*K	Reel - 1 1/8" Hub	304869	R	Rope Clamp Kit	5243506	FF	Washer	205119
*K	Reel - 2 1/2" Hub	304868	U	Locknut (2)	204803	GG	Bolt	204213
L	Gear Cover (B1200G)	406116				HH	Retainer (B1200G)	206589

*Specify Color When Ordering



B1500 & B1500G Winch

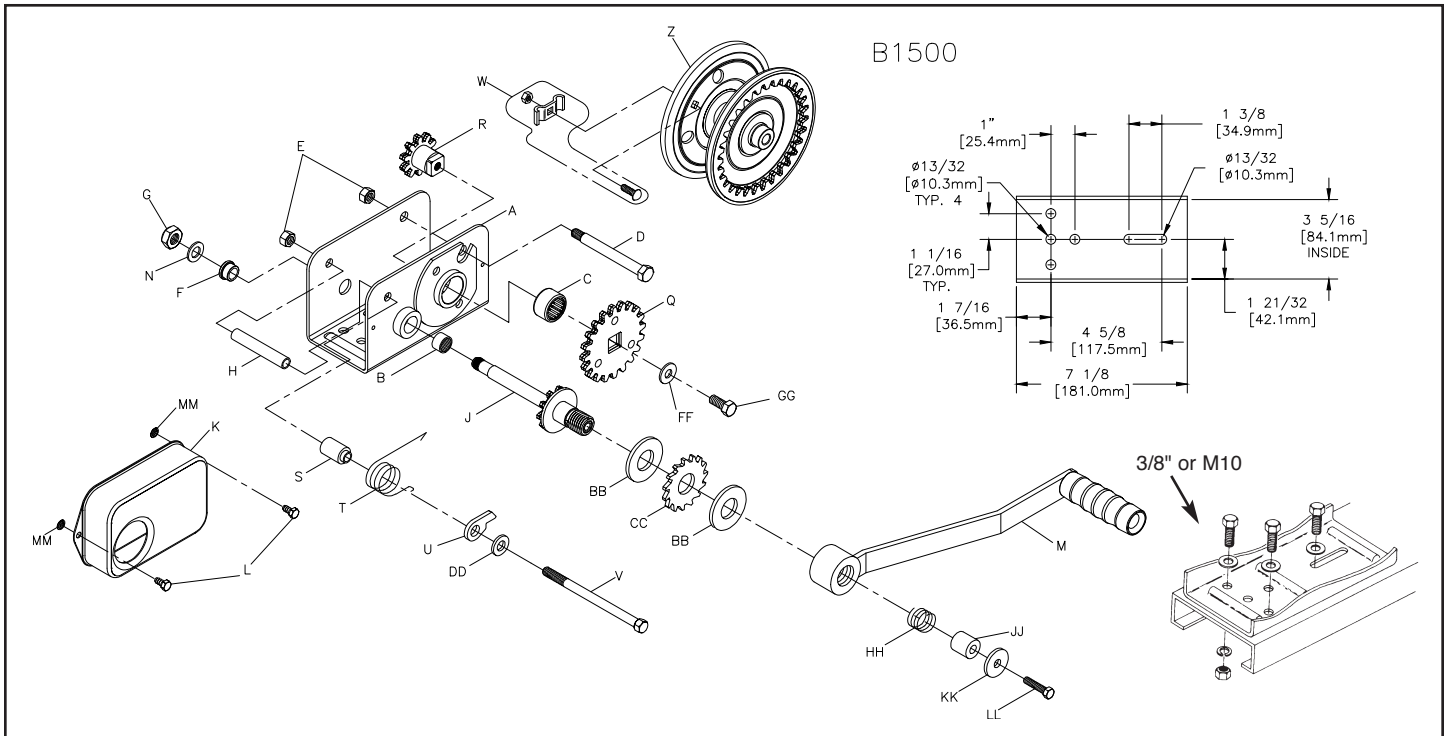

B1500 & B1500G Winch Parts List

Ref.	Description	Part No.	Ref.	Description	Part No.	Ref.	Description	Part No.
*A	Base (B1500)	304358	M	Handle (B1500)	5703509	W	Rope Clamp Kit	5243506
A	Base (B1500G)	304391		w/Decal		*Z	Reel - 1 1/8" Hub	304360
B	Bearing	205131	M	Handle (B1500G)	5146972	*Z	Reel - 2 1/2" Hub	304359
C	Bearing	205130		w/Decal		BB	Pressure Plate (2)	205123
D	Bolt	204805	N	Washer	204360-PL	CC	Ratchet Wheel	404408
E	Locknut (2)	204803	Q	Gear	304173	DD	Washer	205055
F	Bearing	204148	R	Drive Shaft	304169	FF	Washer	205044
G	Locknut	205015	S	Spacer	404369	GG	Bolt	205121
H	Spacer	404371	T	Spring (B1500)	204142	HH	Spring	204212
J	Drive Shaft	304163	T	Spring (2) (B1500G)	204461	JJ	Shaft Extension	404122
*K	Gear Cover	404363	U	Pawl	404409	KK	Washer	205119
L	Screw (2)	205025	V	Bolt (B1500)	205127	LL	Bolt	204213
			V	Bolt (B1500G)	205335	MM	Retainer (B1500G)	206589

*Specify Color When Ordering



B2500 & B2500G Winch

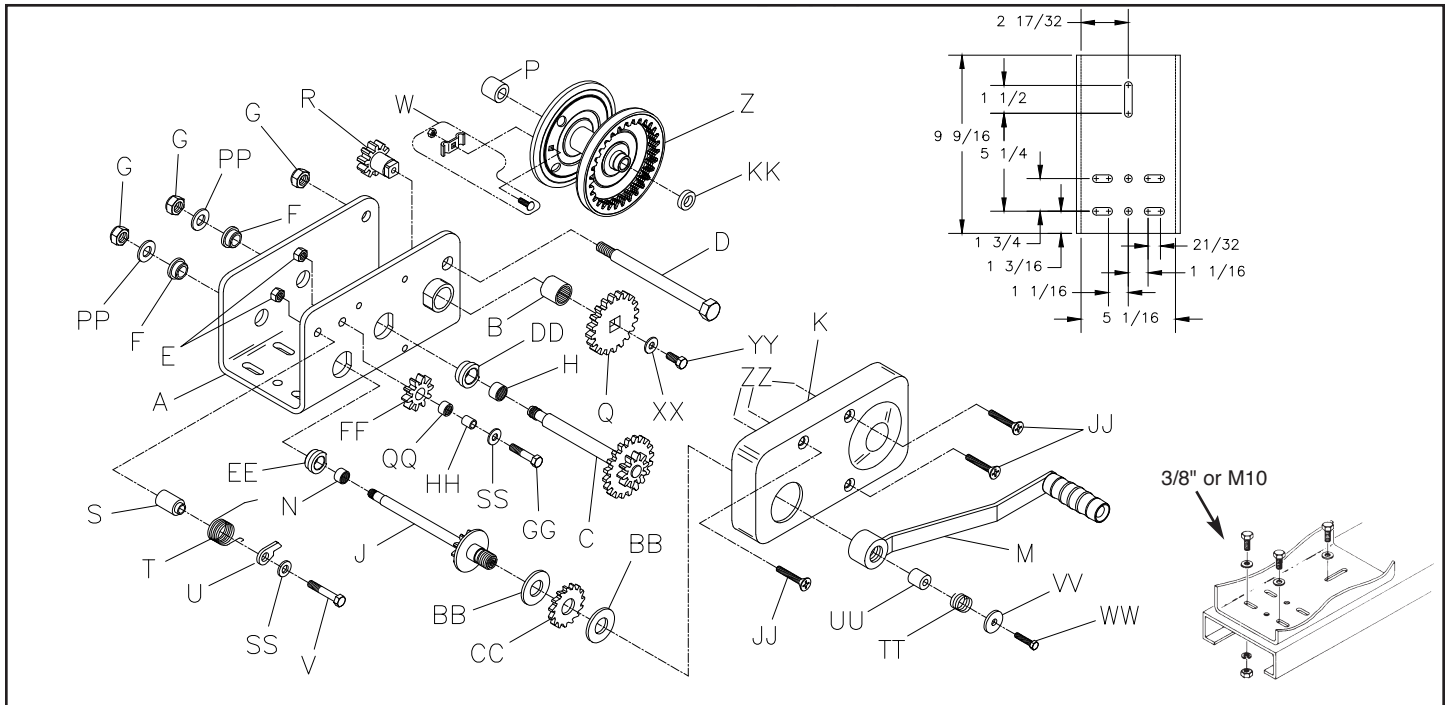

B2500 & B2500G Winch Parts List

Ref.	Description	Part No.	Ref.	Description	Part No.	Ref.	Description	Part No.
*A	Base (B2500)	304481	P	Spacer	404373	FF	Gear	304172
A	Base (B2500G)	304483	Q	Gear	304174	GG	Bolt	203136
B	Bearing	205133	R	Drive Shaft	304170	HH	Spacer	404996
C	Drive Shaft	304167	S	Spacer	404370	JJ	Screw (3)	205125
D	Bolt	204145	T	Spring (B2500)	204142	KK	Spacer	404372
E	Locknut (2)	204803	T	Spring (2) (B2500G)	204461	PP	Washer (2)	204360-PL
F	Bearing (2)	204148	U	Pawl	404409	QQ	Bearing	205134
G	Locknut (3)	205015	V	Bolt	205128	SS	Washer (2)	205055
H	Bearing	205183	W	Rope Clamp Kit	304321	TT	Spring	204212
J	Drive Shaft	304271	*Z	Reel 1 5/16" Hub	304156	UU	Shaft Extension	404122
*K	Gear Cover	404364	*Z	Reel 2 1/2" Hub	304160	VV	Washer	205119
M	Handle (B2500) w/Decal	5703509	*Z	Reel 3 1/8" Hub	304161	WW	Bolt	204213
M	Handle (B2500G) w/Decal	5146972	BB	Pressure Plate (2)	205123	XX	Washer	205044
N	Bearing	205131	CC	Ratchet Wheel	404408	YY	Bolt	205121
			DD	Housing	404476	ZZ	Retainer (B2500G)	206590
			EE	Housing	404479			

*Specify Color When Ordering



B3500 Winch

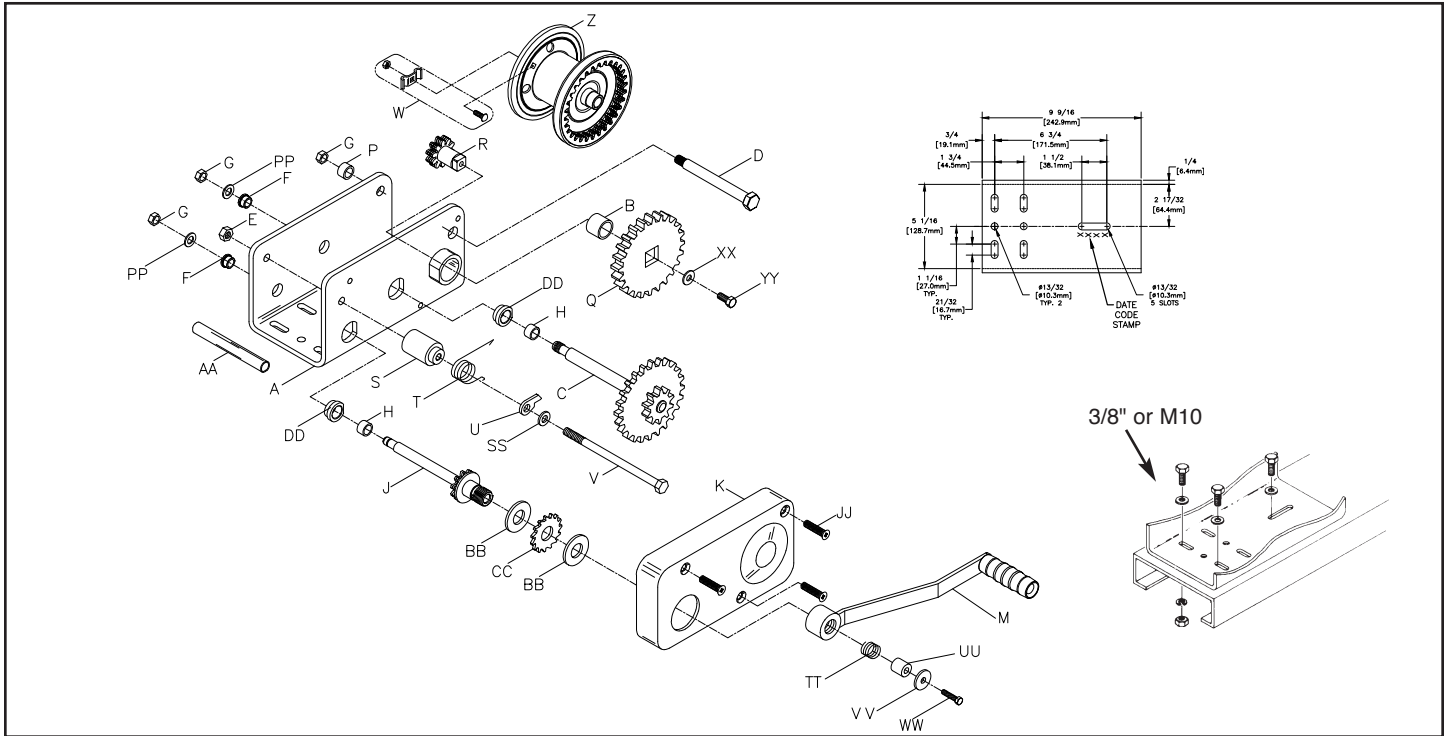

B3500 Winch Parts List

Ref.	Description	Part No.	Ref.	Description	Part No.	Ref.	Description	Part No.
A	Base	304604-PL	M	Handle w/Decal	5703509	AA	Spacer 2 pcs. 404371 & 404723	
B	Bearing	205133	P	Spacer	404718	BB	Pressure Plate (2)	205123
C	Drive Shaft	304599	Q	Gear	304601	CC	Ratchet Wheel	404408
D	Bolt	204145	R	Drive Shaft	304194	DD	Housing (2)	404476
E	Locknut	204803	S	Spacer	404704	JJ	Screw (3)	205125
F	Bearing (2)	204148	T	Spring	204142	PP	Washer (2)	204360-PL
G	Locknut (3)	205015	U	Pawl	404409	SS	Washer	205055
H	Bearing (2)	205183	V	Bolt	404724	TT	Spring	204212
J	Drive Shaft	304595	W	Rope Clamp Kit	304321	UU	Shaft Extension	404122
K	Gear Cover	404703	Z	Reel 3 1/8" Hub	304603-BK	VV	Washer	205119
						WW	Bolt	204213
						XX	Washer	205044
						YY	Bolt	205121