

Model 6121 TRAILER SPARE TIRE BRACKET

The Model 6121 Trailer Spare Tire Bracket fits 3", 4", or 5" rectangular frame members up to 3" wide. Frame members wider than 3" require replacement of existing mounting bolts with bolts of appropriate length. Mounting on a round tongue requires modification to provide a rectangular mounting area. This trailer spare tire bracket is designed for 9" to 14" wheels with either four-hole rims (4" bolt circle) or 5-hole rims (4½" bolt circle). **Maximum tire and wheel size of 14".**

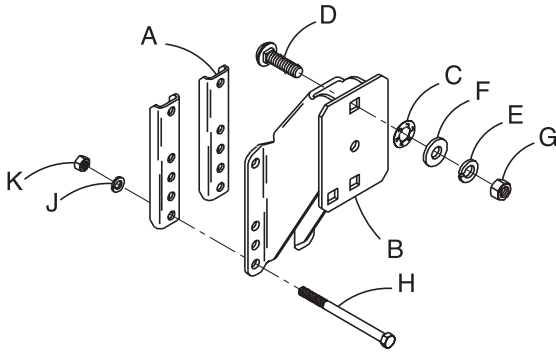

REF. LET.	PART NAME	PART NO.
A	Clamp Plate (2)	403240
B	Bracket Weld Assy.	303532
C	Push Nut (2)	205266
D	Carriage Bolt, ½ x 1½ Lg. (2)	205265
E	Lockwasher - ½ (2)	205264
F	Flat Washer - ½ SAE (2)	205029
G	Hex Nut - ½ (2)	205204
H	Hex Bolt - ¾ - 16 x 4 Lg. (4)	205145
J	Lockwasher - ¾ (4)	205042
K	Hex Nut - ¾ - 16 (4)	205050

INSTALLATION INSTRUCTIONS

Mount the spare tire bracket in a convenient location on the trailer frame or tongue using the two clamp plates and 4" long bolts, lock washers and nuts as shown. Attach carriage bolts (D) through backside of top plate and attach push nuts (C) to keep bolts from falling out. Use the top and bottom center square holes for a four-hole rim and use the top and bottom corner square holes for a five-hole rim. Place the spare tire in position on the mounting bolts and secure with flat washers, lock washers, and nuts as shown.

To guard against theft, a security cable and lock (not included) can be placed through the center hole in the top plate and the center hub hole in the wheel to lock the wheel and bracket to the trailer.



Learn more about spare tire covers and carriers we have.