

DL1800A, DL2000A, DL2500A & DL3200A

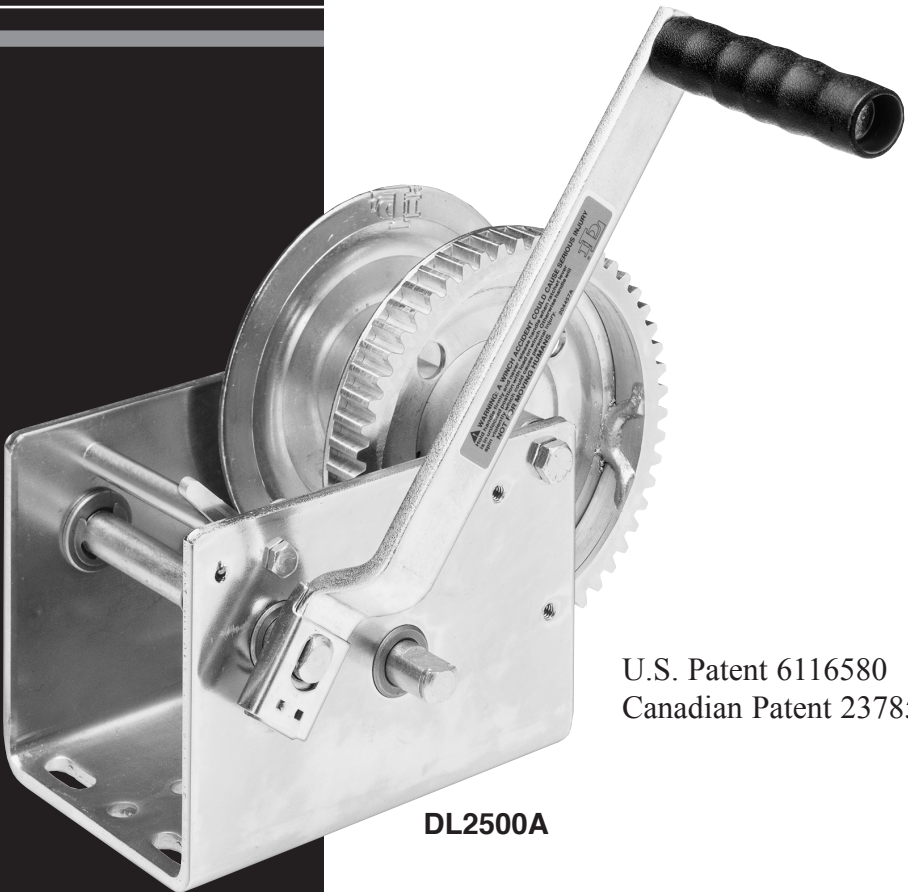

PULLING WINCHES



U.S. Patent 6116580
Canadian Patent 2378538

DL2500A



⚠ WARNING READ INSTRUCTIONS CAREFULLY BEFORE ATTEMPTING TO INSTALL, OPERATE OR SERVICE THIS WINCH. FAILURE TO COMPLY WITH INSTRUCTIONS COULD RESULT IN SERIOUS OR FATAL INJURY. RETAIN THESE INSTRUCTIONS FOR FUTURE REFERENCE.



IMPORTANT SAFETY INFORMATION

- This winch is built for multi-purpose hauling and pulling operations. It is not recommended for lifting applications. For lifting, use a self-locking winch. DL winches are not to be used as hoists for lifting, supporting or transporting people, or for loads over areas where people could be present.
- Respect this winch. High forces are created when using a winch, creating potential safety hazards. It should be operated and maintained in accordance with instructions. Never allow children or anyone who is not familiar with the operation of the winch to use it.
- Maintain a firm grip on the winch handle at all times, and never release the handle when ratchet lever is in unlocked position with a load on the winch. Otherwise, handle will spin violently, which could cause personal injury.
- Check for proper ratchet operation on each use of the winch. Do not use if damaged. Seek immediate repairs.
- Never use the winch handle as a convenient handle for pulling or maneuvering the entire trailer or other equipment. Never pull on the winch handle against a locked ratchet.
- Never exceed rated capacity. Excess load may cause premature failure and could result in serious personal injury. This winch is rated with three layers of line on the hub. Using more layers of line or a large hub increases the load on the winch.
- Never apply load on winch with cable or rope fully extended. Keep at least three full turns of cable or rope on the reel.
- Secure load properly. When winching operation is complete, do not depend on winch to support load.
- Operate with hand power only. This winch should not be operated with a motor of any kind. If the winch cannot be cranked easily with one hand, it is probably over-loaded.

WINCH MOUNTING AND CABLE ATTACHMENT

— For maximum strength and safety, (and compliance with SAE Standard J1853) this winch should be mounted with three $\frac{3}{8}$ " or M10 bolts, washers, and lock washers. (Use grade 5 or 8 for DL2500A, 2500AB, DL3200A & 3200AB). See parts drawing.

Select a winch line with breaking strength at least 1-1/2 times the winch rating and a hook 1-1/2 times stronger than the line. If steel cable is

selected, the optional reel with large hub may extend cable life. (The above combination meets SAE Standard J1853 for boat trailer winches).

Attach cable or rope by either method described in sketch. If nylon strap is used, it should have a loop sewn in one end and be attached using a $\frac{3}{8}$ " x $3\frac{1}{4}$ " long bolt and locknut. Use a locknut, not a nut and lockwasher. Insert bolt through slots in both reel sideplates so that nut is on gear side. Tighten only until snug with bolt in bottom of slot next to reel hub.

OPERATING INSTRUCTIONS

— Attach winch handle securely to primary drive shaft (upper or low speed shaft). Make sure that handle clip engages with groove in drive shaft. Wind line on winch reel by turning winch handle in counterclockwise direction with ratchet lever in "down" position. The ratchet should produce a loud, sharp, clicking noise. Make sure that ratchet lever is in "down" position and holding load before winch handle is released. To unwind or reel out line, securely grip winch handle and apply force in counterclockwise direction so that ratchet lever can easily be moved to "up" position. Carefully turn handle in clockwise direction. Do not lose control. If handle is attached to intermediate (lower or high speed) shaft, operate as described above, reversing clockwise and counterclockwise. The winch can be converted to wind line on to the underside of the reel. To do this, carefully examine ratchet assembly and remove it from winch. Do not

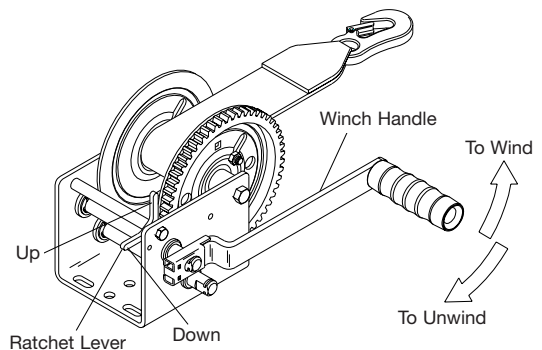

lose small parts. Turn the lever over and reassemble. Do not over tighten bolt. Check operation to insure the ratchet lever rotates fully without binding.

WINCH MAINTENANCE — This winch has been fully lubricated at the factory; but, for continued smooth performance and increased life, occasional greasing of gears and reel shaft and an occasional

drop of oil on drive shaft bearings are recommended. Keep winch in good working order. Damaged or severely-worn parts create unnecessary dangers and could result in personal injury or property damage.

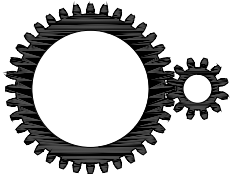

DL1800A – 10.3:1/5.4:1
DL2000A – 12.4:1/5.4:1
DL2500A – 17.3:1/5.4:1
DL3200A – 17.3:1/5.4:1

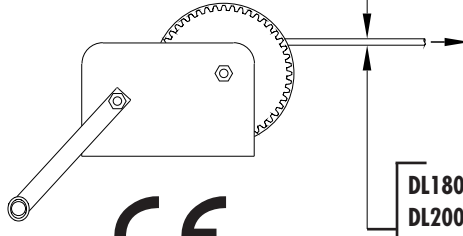

DL1800A – 1800 lbs/817 kg
DL2000A – 2000 lbs/907 kg
DL2500A – 2500 lbs/1134 kg
DL3200A – 3200 lbs/1452 kg

CABLE

DL1800A – $\frac{9}{32}$ " x 58 ft (7 mm x 17.9 m)
DL2000A – $\frac{9}{32}$ " x 58 ft (7 mm x 17.9 m)
DL2500A – $\frac{5}{16}$ " x 47 ft (8 mm x 14.2 m)
DL3200A – $\frac{3}{8}$ " x 30 ft (9 mm x 10.1 m)

ENGLISH – DECLARATION OF CONFORMITY - Dutton-Lainson Company, Hastings, NE 68902-0729 U.S.A. manufactures and declares that the winch identified above fulfills all relevant provisions of the Directive 2006/42/EC. The technical file may be obtained from the persons listed below.



DL1800A, DL2000A, DL2500A, DL3200A

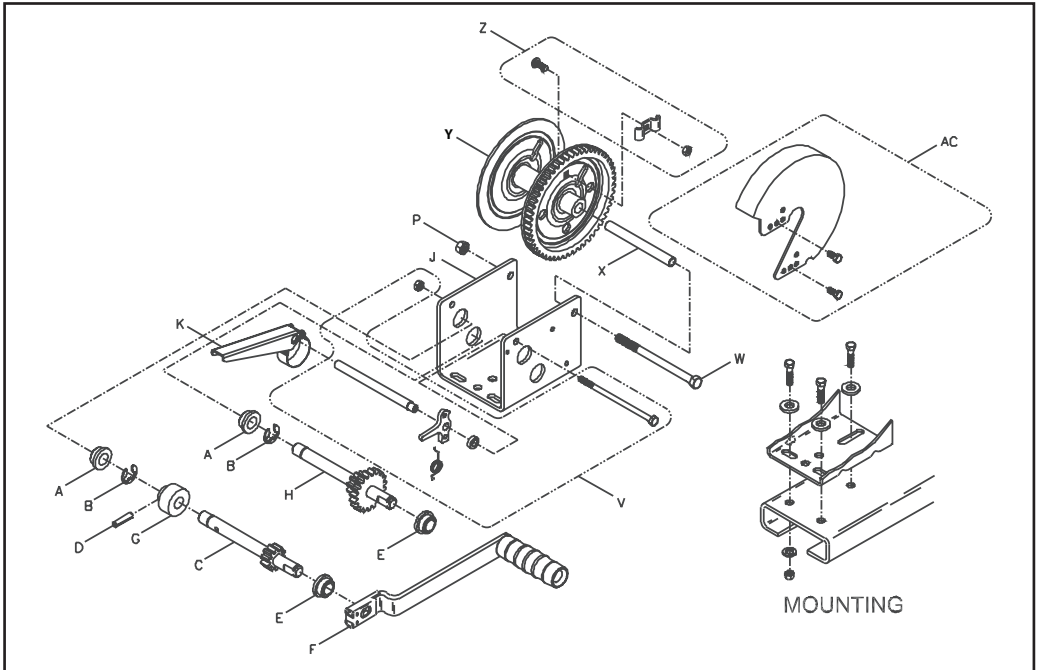

Ref	Description	Part No.
A	Bushing (2)	204009
B	E-Ring (2)	205116
C	Drive Shaft - DL1800A, 2000A, 2500A	304726
C	Drive Shaft - DL3200A	304736
C	Dr. Shaft w/Hole - DL1800A thru 2500A	304780
C	Dr. Shaft w/Hole - DL3200A	304787
D	Pin (Optional)	207255
E	Bushing (2)	204012
F	Handle	5703301
G	Drum (Optional)	404910
H	Drive Shaft - DL1800A	304732
H	Drive Shaft - DL2000A	304733
H	Drive Shaft - DL2500A	304727
H	Drive Shaft - DL3200A	304737
H	Drive Shaft - DL2500A, Spec. Opt.	304781
J	Base - DL1800A	404879*
J	Base - DL2000A	404880*
J	Base - DL2500A	404875*
J	Base - DL3200A	404907*

Ref	Description	Part No.
K	Brake Band/Handle Assy.	304810
P	Locknut	204803
V	Ratchet Kit	5704754
W	Reel Shaft - DL1800A	205127
W	Reel Shaft - DL2500A, 2000A	204804
W	Reel Shaft - DL3200A	205335
X	Spacer (Reel)	204808
Y	Reel (1-1/8" Hub) - DL1800A, 2000A	304730*
Y	Reel (2-1/2" Hub) - DL1800A, 2000A, Opt.	304755*
Y	Reel (1-1/8" Hub) - DL2500A	304728*
Y	Reel (2-1/2" Hub) - DL2500A, Opt.	304783*
Y	Reel (1-1/8" Hub) - DL3200A	304735*
Y	Reel (2-1/2" Hub) - DL3200A, Opt.	304788*
Z	Rope Clamp Kit	5243506
AC	Gear Cover - DL1800A, DL2000A, DL2500A, Opt., Bronze	5240387
AC	Gear Cover - DL1800A, DL2000A, DL2500A, Opt., Plated	5240403

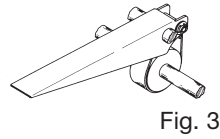
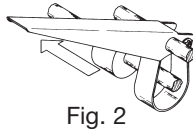
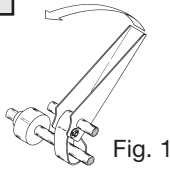
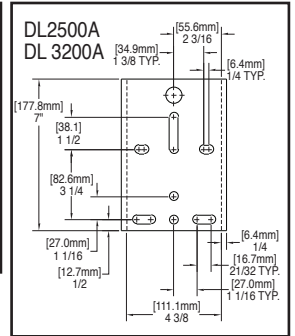
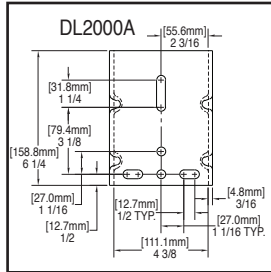
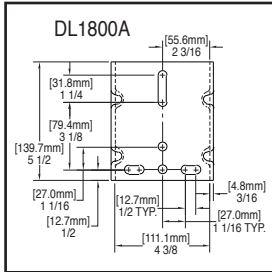
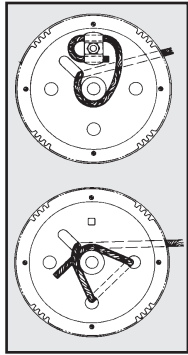

ENGLISH – For Brake Equipped Winches: Initial Use

NOTE: The hand brake has been shipped in a retracted position to eliminate the possibility of damage during shipping. It may be quickly positioned for operation as follows:

1. Rotate the brake handle back from the forward position in FIG. 1 to the nearly horizontal position in FIG. 2.
2. Slide the brake assembly sideways until the band can be guided around the drum. The band should not overhang the drum on either side.
3. Lock the handle in place by pushing it down to the fully horizontal position in FIG. 3. The brake assembly will now stay in place and is ready to use.