



**! WARNING** READ INSTRUCTIONS CAREFULLY BEFORE ATTEMPTING TO INSTALL, OPERATE OR SERVICE THIS WINCH. FAILURE TO COMPLY WITH INSTRUCTIONS COULD RESULT IN SERIOUS OR FATAL INJURY. RETAIN THESE INSTRUCTIONS FOR FUTURE REFERENCE.



## IMPORTANT SAFETY INFORMATION

- This winch is built for multi-purpose hauling and pulling operations. It is not recommended for lifting applications. For lifting, use a self-locking winch. DL winches are not to be used as hoists for lifting, supporting or transporting people, or for loads over areas where people could be present.
- Respect this winch. High forces are created when using a winch, creating potential safety hazards. It should be operated and maintained in accordance with instructions. Never allow children or anyone who is not familiar with the operation of the winch to use it.
- Maintain a firm grip on the winch handle at all times, and never release the handle when ratchet lever is in unlocked position with a load on the winch. Otherwise, handle will spin violently, which could cause personal injury.
- Check for proper ratchet operation on each use of the winch. Do not use if damaged. Seek immediate repairs.
- Never use the winch handle as a convenient handle for pulling or maneuvering the entire trailer or other equipment. Never pull on the winch handle against a locked ratchet.
- Never exceed rated capacity. Excess load may cause premature failure and could result in serious personal injury. This winch is rated with three layers of line on the hub. Using more layers of line or a large hub increases the load on the winch.
- Never apply load on winch with cable or rope fully extended. Keep at least three full turns of cable or rope on the reel.
- Secure load properly. When winching operation is complete, do not depend on winch to support load.
- Operate with hand power only. This winch should not be operated with a motor of any kind. If the winch cannot be cranked easily with one hand, it is probably over-loaded.

## WINCH MOUNTING AND CABLE ATTACHMENT

— For maximum strength and safety, (and compliance with SAE Standard J1853) this winch should be mounted with three  $\frac{3}{8}$ " or M10 bolts, washers, and lock washers. (See parts drawing).

Select a winch line with breaking strength at least  $1\frac{1}{2}$  times the winch rating and a hook  $1\frac{1}{2}$  times stronger than the line. If steel cable is selected, the optional reel with large hub may extend cable life. (The above combination meets SAE Standard

J1853 for boat trailer winches).

Attach cable or rope by either method described in sketch. If nylon strap is used, it should have a loop sewn in one end and be attached using a  $\frac{3}{8}$ " x 3" (DL 1100A & DL1300A) or  $\frac{1}{4}$ " x 2-3/4" (DL600A & DL900A) long bolt and locknut. Use a locknut, not a nut and lockwasher. Insert bolt through slots in both reel sideplates so that nut is on gear side. Tighten only until snug with bolt in bottom of slot next to reel hub.

**OPERATING INSTRUCTIONS** — HANDLE AND NUT MUST BE TIGHTENED AGAINST DRIVE SHAFT BEFORE OPERATING WINCH. Wind line on winch reel by turning winch handle in clockwise direction with ratchet lever in "on" position. The ratchet should produce a loud, sharp, clicking noise. Make sure that ratchet lever is in "on" position and holding load before winch handle is released. To unwind or reel out line, securely grip winch handle and apply force in clockwise direction so that ratchet lever can easily be moved to "off" position. Carefully turn handle in counterclockwise direction. Do not lose control.

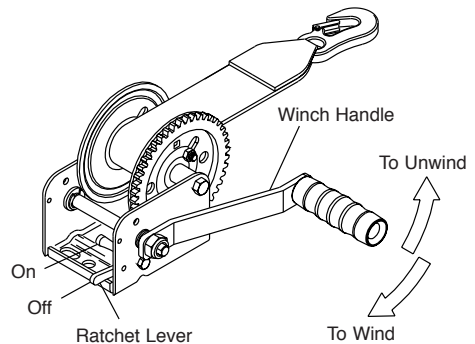

**WINCH MAINTENANCE** — This winch has been fully lubricated at the factory; but, for continued smooth performance and increased life, occasional greasing of gears and reel shaft and an occasional drop of oil on drive shaft bearings are recommended.

Keep winch in good working order. Damaged or severely-worn parts create unnecessary dangers and could result in personal injury or property damage.

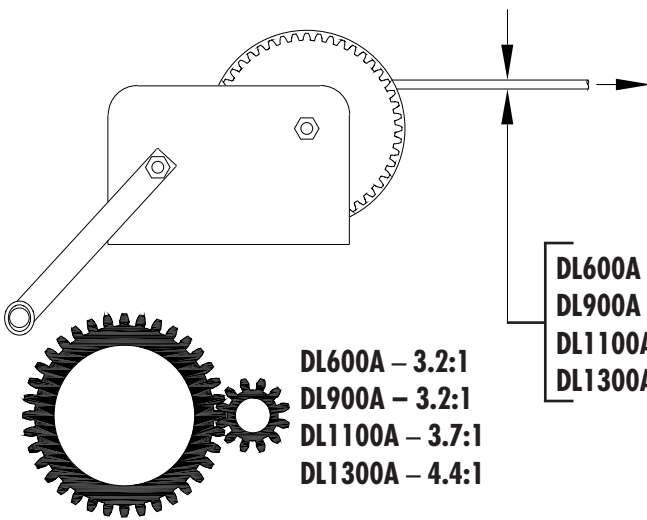

DL600A – 600 lbs/272 kg  
 DL900A – 900 lbs/408 kg  
 DL1100A – 1100 lbs/499 kg  
 DL1300A – 1300 lbs/590 kg

DL600A – 3.2:1  
 DL900A – 3.2:1  
 DL1100A – 3.7:1  
 DL1300A – 4.4:1

**CABLE**

DL600A –  $\frac{5}{32}$ " x 61 ft (4 mm x 19.2 m)  
 DL900A –  $\frac{3}{16}$ " x 40 ft (5 mm x 10.9 m)  
 DL1100A –  $\frac{3}{16}$ " x 79 ft (5 mm x 22.2 m)  
 DL1300A –  $\frac{7}{32}$ " x 56 ft (6 mm x 14.2 m)





# DL600A & DL900A

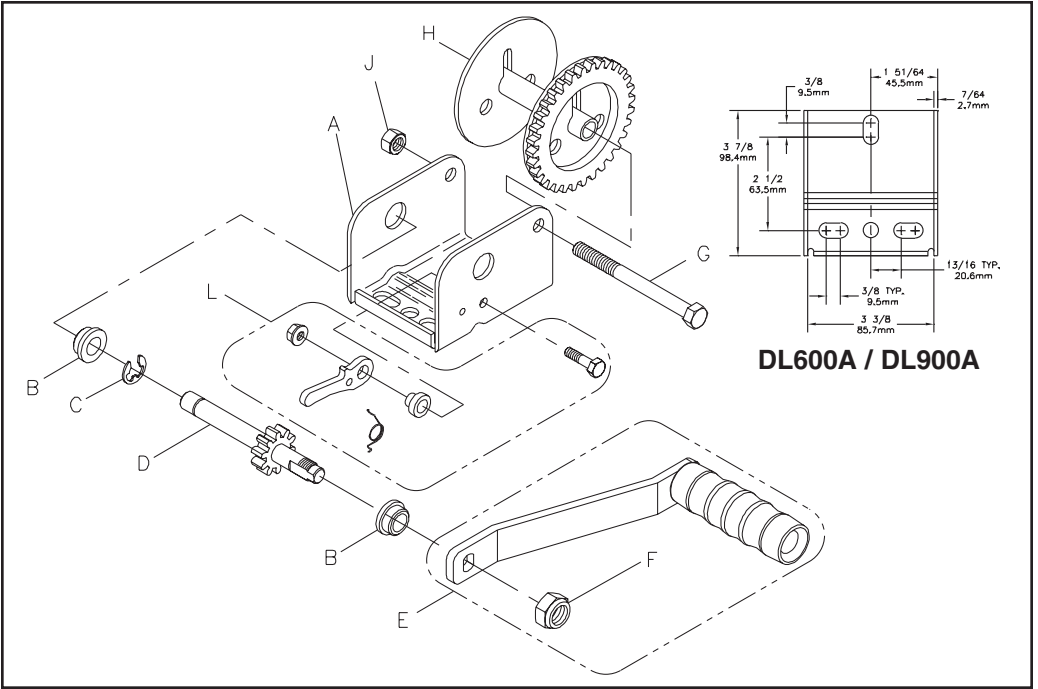

# DL1100A & DL1300A

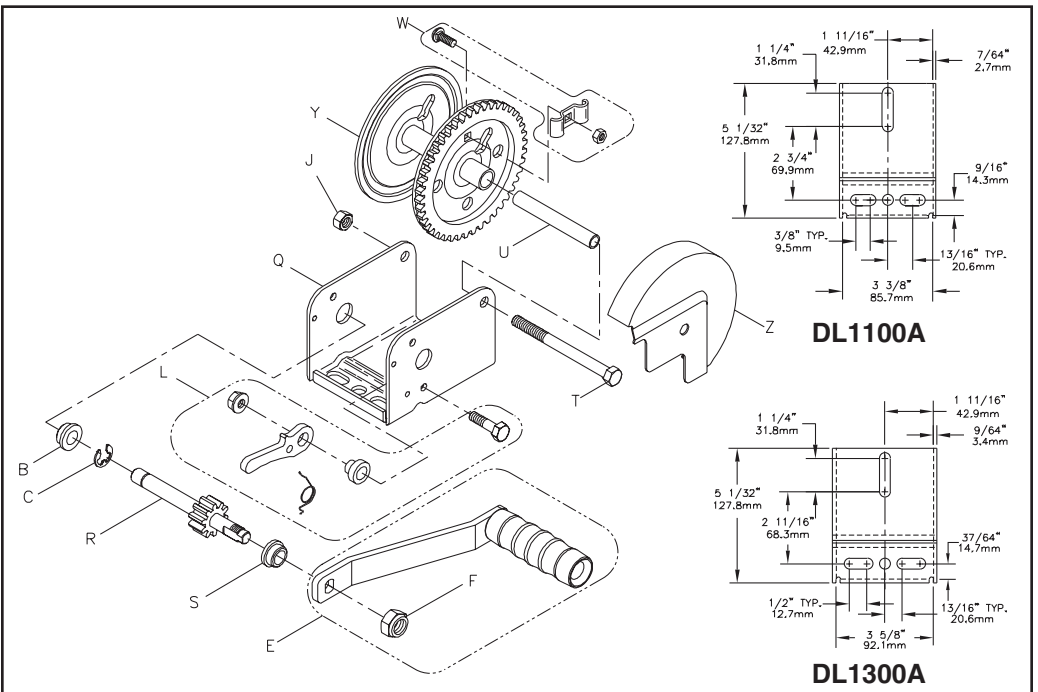

Ref	Description	Part No.
A	Base - DL600A	404882*
A	Base - DL900A	404869*
B	Bushing	204006
C	E-Ring	205012
D	Drive Shaft - DL600A	304720
D	Drive Shaft (DL600A Threaded Both Ends), Opt.	304762
D	Drive Shaft - DL900A	304718
E	Handle 7" w/Nut	5703046
E	Handle 6" w/Nut	5703657
E	Handle 5"	5703442
F	Nut	205015
G	Reel Shaft	204805
H	Reel (5/8" Hub) - DL600A	304721*
H	Reel (1" Hub), Opt. - DL 600A	304750*
H	Reel (5/8" Hub) - DL900A	304719*
H	Reel (1" Hub), Opt. - DL900A	304749*
J	Locknut	204803
L	Ratchet Kit	5704531

\*Specify Color When Ordering

Ref	Description	Part No.
Q	Base - DL1100A	404876*
Q	Base - DL1300A	404883*
R	Drive Shaft - DL1100A	304716
R	Drive Shaft (DL1100A Threaded Both Ends) Opt.	304763
R	Drive Shaft - DL1300A	304722
S	Bushing - DL1300A (1)	204007
T	Reel Shaft - DL1100A	205144
T	Reel Shaft - DL1300A	203161
U	Spacer - DL1100A	206072
U	Spacer - DL1300A	204807
W	Rope Clamp Kit	5243506
Y	Reel (7/8" Hub) - DL1100A	304717*
Y	Reel (1-1/4" Hub ) DL1100A, Opt.	304752*
Y	Reel (7/8" Hub) - DL1300A	304723*
Y	Reel (1-7/8" Hub) - DL1300A, Opt.	306062*
Z	Gear Cover - DL1100A-PL, Opt.	5240247
Z	Gear Cover - DL1100A-BZ, Opt.	5240148
Z	Gear Cover - DL1300A-PL, Opt.	5240197
Z	Gear Cover - DL1300A-BZ, Opt.	5240213

