

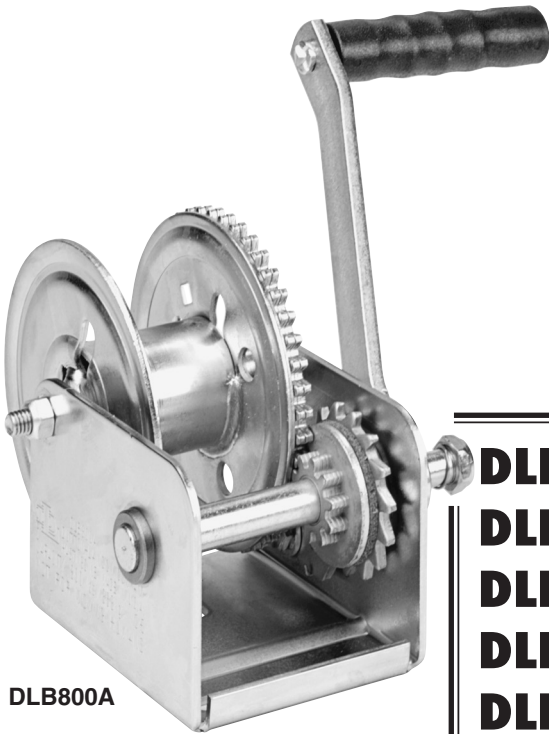

# BRAKE WINCHES



DLB800A

**DLB350A**  
**DLB350AG**  
**DLB800A**  
**DLB800AG**  
**DLB1200A**  
**DLB1200AG**  
**DLB1500A**  
**DLB1500AG**  
**DLB2000AG**  
**DLB2500A**

MANUFACTURED BY

MADE IN U.S.A.



**DUTTON-LAINSON**  
**COMPANY** *SINCE 1886*

**ISO 9001: 2008 REGISTERED Q.M.S.**



**WARNING** READ INSTRUCTIONS CAREFULLY BEFORE ATTEMPTING TO INSTALL, OPERATE OR SERVICE THIS WINCH. FAILURE TO COMPLY WITH INSTRUCTIONS COULD RESULT IN SERIOUS OR FATAL INJURY. RETAIN THESE INSTRUCTIONS FOR FUTURE REFERENCE.



### IMPORTANT SAFETY INFORMATION

- This brake winch is built for multi-purpose hauling and lifting operations. It is not to be used as a hoist for lifting, supporting or transporting people, or for loads over areas where people could be present.
- Respect this winch. High forces are created when using a winch, creating potential safety hazards. It should be operated and maintained in accordance with instructions. Never allow children or anyone who is not familiar with the operation of the winch to use it. A winch accident could result in personal injury.
- Check winch for proper operation on each use. Do not use if damaged. Seek immediate repairs.
- Never exceed rated capacity. Excess load may cause premature failure and could result in serious personal injury. This winch is rated on first layer of cable on the hub. Using more layers of cable increases the load on the winch.
- Never apply load on winch with cable fully extended. Keep at least three full turns of cable on the reel. Check cable on every use. Replace at the first sign of kinks, broken wires, deformation or any other damage.
- Secure load properly. When winching operation is complete, do not depend on winch to support load.
- Operate with hand power only. This winch must not be operated with a motor of any kind. If the winch cannot be cranked easily with one hand, it is probably over-loaded.
- If winch will be used in freezing, icy conditions, apply silicone spray to ratchet pawl and spacer items, V, W, X, or Y. Do not spray other brake mechanism parts.

**ASSEMBLY** – Thread the handle onto the winch drive shaft and be certain that a clicking noise is produced when the handle is turned clockwise. Install the spring and locknut (Items E and G) on the end of the drive shaft as shown on parts drawing. These parts may appear to serve no function, but they provide several important fail-safe features, and must not be altered or removed.

### WINCH MOUNTING AND CABLE ATTACHMENT

– For maximum strength and safety, this winch must be mounted with three 3/8" bolts (M10), washers and lock washers. Use Grade 8 for 1500 lb/680 kg or greater capacity. (See parts drawing). Using fewer bolts or alternate locations will result in damage to the winch base and the winch may malfunction.

Attach cable or rope by method shown in sketch.

**OPERATING INSTRUCTIONS** – Wind cable on winch reel by turning winch handle in clockwise direction. This should produce a loud, sharp, clicking noise. The load will remain in position when the handle is released. Wind cable off the winch reel by turning winch handle counterclockwise (no noise will be produced). The load will remain in position when the handle is released, but for extra security it is recommended that the handle be turned clockwise until at least two clicks are heard. This will add extra tightness to the brake mechanism. Always satisfy yourself that the winch is holding the load before releasing the winch handle.

**! IMPORTANT:** Sufficient load must be applied to the cable to overcome internal resistance and operate the brake properly, otherwise turning the crank handle counterclockwise will only remove the han-

dle from the shaft – the reel will not turn. The minimum operating load requirement is 50 lb (23 kg) for Models DLB350A, DLB350AG, DLB800A, DLB800AG, DLB1200A and DLB1200AG, 75 lb (34 kg) for DLB1500A and DLB1500AG, 175 lb (80 kg) for DLB2000AG and DLB2500A.

A lockout lever for the purpose of 'freewheeling' cable out when there is no load on the winch can be added to all DLB winches except the 350 lb (160 kg) models. To 'freewheel' cable out, simply turn the handle counterclockwise until lockout lever can be engaged behind handle hub. In this condition cable can be easily pulled from the winch drum.

**! WARNING:** Never put winch in freewheel mode if any potential for a load on the cable exists. Engaging the lockout lever keeps the winch from stopping in the event that a load is accidentally applied.

**WINCH MAINTENANCE** – In order to insure maximum performance, a periodic inspection for any necessary preventive maintenance must be made. Check at least once annually and more frequently when the winch is exposed to an environment which is particularly dirty or wet. For continued smooth performance and increased life, occasional grease gears, reel shaft and handle threads. An

occasional drop of oil on the drive shaft bearings is also recommended. If winch will be used in freezing, icy conditions, apply silicone spray to ratchet pawl and spacer items V, W, X or Y. **Note: Do not oil or grease brake mechanism items H and J.**

Keep winch in good working order. Damaged or severely-worn parts create unnecessary dangers and could result in personal injury or property damage.



NOT FOR THE MOVEMENT OF HUMAN BEINGS

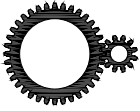
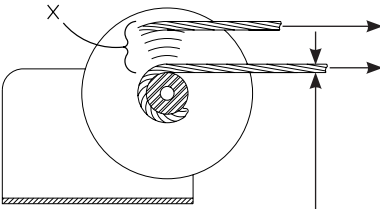

<b>DLB350A</b> <b>DLB350AG</b>	<b>3.2:1</b>
<b>DLB800A</b> <b>DLB800AG</b>	<b>4.4:1</b>
<b>DLB1200A</b> <b>DLB1200AG</b>	<b>5.4:1</b>
<b>DLB1500A</b> <b>DLB1500AG</b>	<b>5.4:1</b>
<b>DLB2000AG</b> <b>DLB2500A</b>	<b>17.3:1</b>

	<b>X</b>	
<b>DLB350A, DLB350AG</b>	<b>10</b>	<b>110 lb/50kg</b>
	<b>1</b>	<b>350 lb/160kg</b>
<b>DLB800A, DLB800AG</b>	<b>9</b>	<b>330 lb/150kg</b>
	<b>1</b>	<b>800 lb/360kg</b>
<b>DLB1200A, DLB1200AG</b>	<b>8</b>	<b>551 lb/250kg</b>
	<b>1</b>	<b>1200 lb/545kg</b>
<b>DLB1500A, DLB1500AG</b>	<b>6</b>	<b>728 lb/330kg</b>
	<b>1</b>	<b>1500 lb/680kg</b>
<b>DLB2000AG</b>	<b>5</b>	<b>959 lb/435kg</b>
	<b>1</b>	<b>2000 lb/905kg</b>
<b>DLB2500A</b>	<b>5</b>	<b>1308 lb/593kg</b>
	<b>1</b>	<b>2500 lb/1134kg</b>

<b>DLB350A</b>	<b>1/8" (2000 lb) x 84'</b>
<b>DLB350AG</b>	<b>3mm (480kg) x 24.9m</b>
<b>DLB800A</b>	<b>3/16" (4200 lb) x 68'</b>
<b>DLB800AG</b>	<b>4mm (1080kg) x 23.0m</b>
<b>DLB1200A</b>	<b>7/32" (5600 lb) x 69'</b>
<b>DLB1200AG</b>	<b>5mm (1640kg) x 19.7m</b>
<b>DLB1500A</b>	<b>1/4" (7000 lb) x 60'</b>
<b>DLB1500AG</b>	<b>6mm (2040kg) x 15.1m</b>
<b>DLB2000AG</b>	<b>7mm (2720kg) x 8.9m</b>
<b>DLB2500A</b>	<b>5/16" (9800 lb) x 34'</b>

**ENGLISH – DECLARATION OF CONFORMITY** - Dutton-Lainson Company, Hastings, U.S.A. manufactures and declares that the winch identified above fulfills all relevant provisions of the Directive 2006/42/EC. 'G' models also conform to harmonized standards EN 13157 and EN ISO 12100. The technical file may be obtained from the persons listed below.





## DLB1200A & DLB1200AG Winch

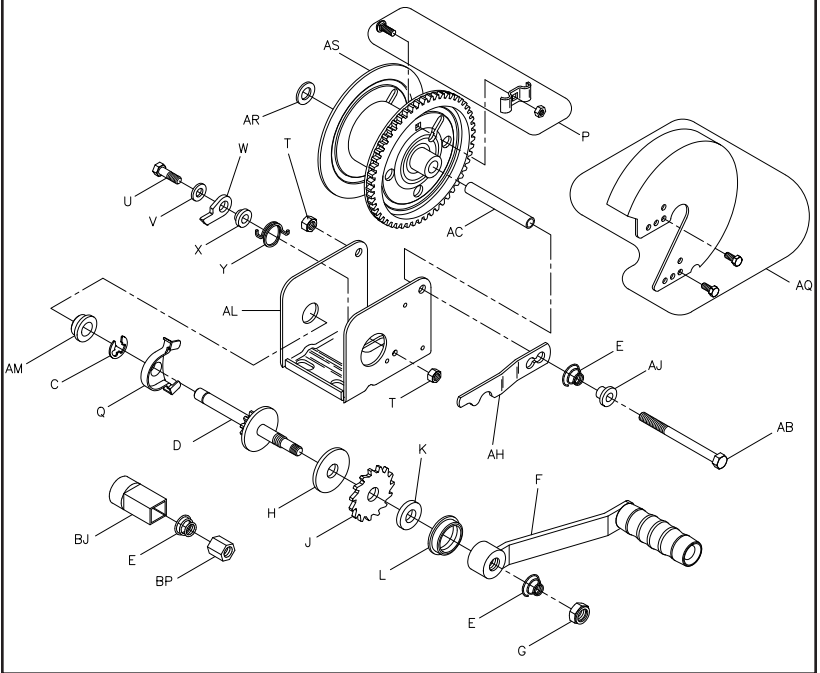

## DLB1500A & DLB1500AG Winch

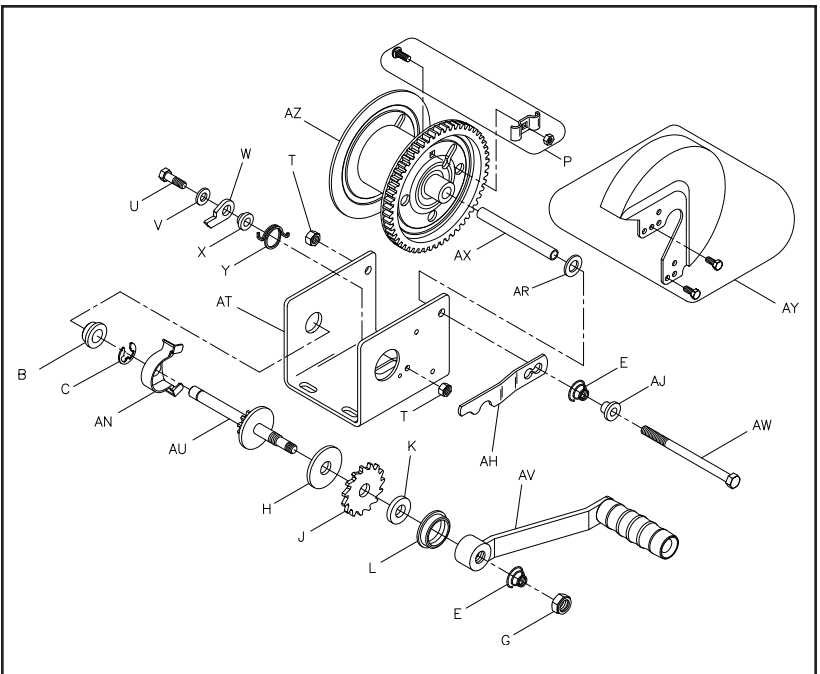



# PARTS LIST

Ref	Description	Part No.
A	Base	404900*
A	Base – DLB 350AG	404945*
B	Bushing	204012
C	“E” Ring	205116
D	Drive Shaft	306061
E	Spring	204364
F	Handle – 7” (DLB350AG)	5703061
	(DLB800AG)	
	Handle – 9-3/8” (DLB1200AG)	5703103
G	Nut	205033
H	Pressure Plate	204362
H	Pressure Plate “G” Series	206620
J	Ratchet Wheel	404164
K	Pressure Washer	404163
L	Bushing	206328
M	Nut	205316
N	Bolt	205332
P	Rope Clamp Kit	5243506
Q	Gear Cover – “G” Series	406114
S	Reel	306075*
	Reel - DLB350AG	306167
T	Locknut	204803
U	Bolt	205167
V	Flat Washer	205055
W	Pawl	404409
	Pawl – “G” Series	404190
X	Spacer	404166
	Spacer – “G” Series	404191
Y	Spring	204363
	Spring – “G” Series	204460
Z	Reel Spacer	207183
AB	Bolt	203161
AC	Reel Spacer	204807
AE	Reel	306062*
AF	Base	404893*
	Base – DLB 800AG	404895*

Ref	Description	Part No.
AH	Lockout Lever (optional)	404579
AJ	Spacer (optional)	406160
AK	Gear Cover (optional)	
	Painted Bronze	5240346
	Plated	5240361
AL	Base	404896*
	Base – DLB 1200AG	404897*
AM	Bushing	204009
AN	Gear Cover – “G” Series	406115
AQ	Gear Cover (optional)	
	Painted Bronze	5240122
	Plated	5240221
AR	Spacer Washer	205120
AS	Reel (DLB1200AG)	304754*
AS	Reel – 1-7/8” (optional)	304768*
AT	Base	404891*
	Base – DLB 1500AG	404892*
AU	Drive Shaft	304760
AV	Handle – 9-3/8” (DLB2000AG)	5703103
	Handle – 12” (DLB1500AG)	5703111
AW	Bolt	204804
AX	Reel Spacer	204808
AY	Gear Cover (optional)	
	Painted Bronze	5240387
	Plated	5240403
AZ	Reel	304755*
BA	Base – DLB2500A	406047*
	Base – DLB 2000AG	404899*
BB	Spacer	404434
BC	Bolt	205006
BD	Flat Washer	205139
BE	Intermed. Drive Shaft	306035
BF	Nut	205014
BH	Reel	304756*
BJ	Drive Hub (Optional)	304562
BM	Handle w/Lock Pin (Opt)	5703426
BN	Handle Hub (Optional)	304630
BP	Special Nut (Optional)	404970
BQ	“E” Ring	206162
BR	Bushing	206163
BS	Bolt	205335

\*Specify Color When Ordering

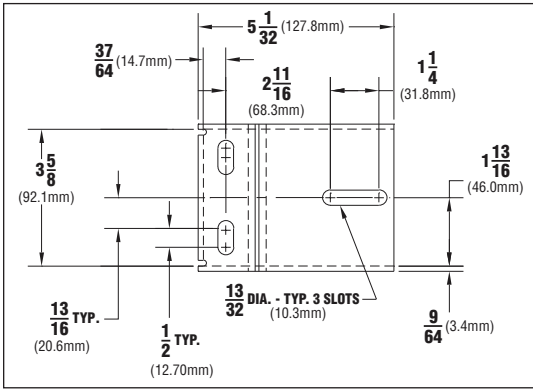

**DLB350A, DLB350AG,  
DLB800A, DLB800AG,  
DLB1200A, DLB1200AG**

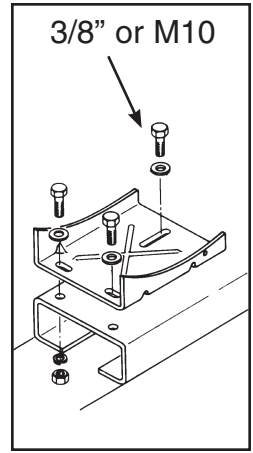

**DLB1500A  
DLB1500AG**

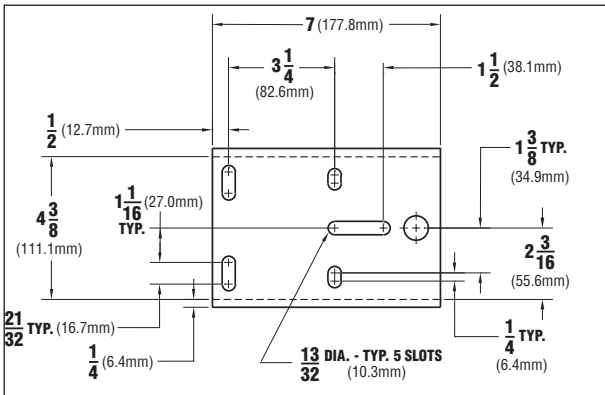
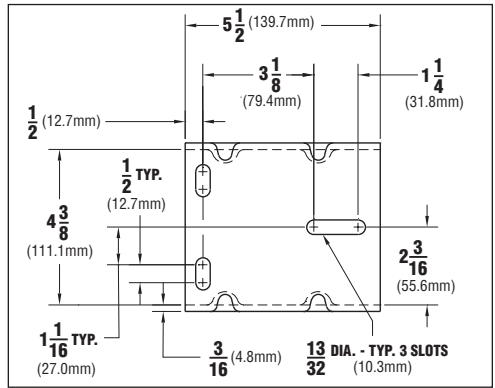

**DLB2000AG  
DLB2500A**

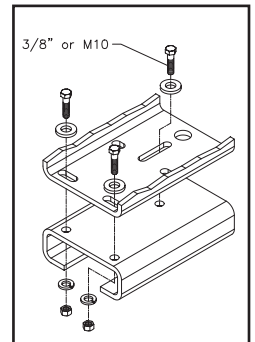

**WARNING** Component parts should not be interchanged with the component parts of any other Dutton-Lainson model or other manufacturer's winches.