

DL1602ADD

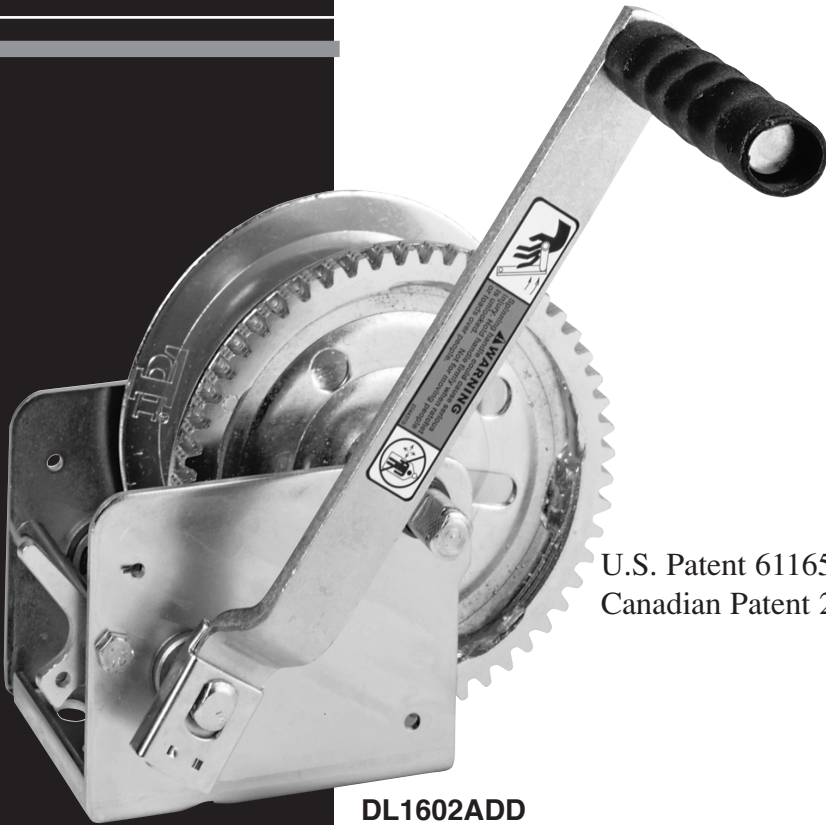

PULLING WINCHES



U.S. Patent 6116580
Canadian Patent 2378538

DL1602ADD



MADE IN
USA

! WARNING READ INSTRUCTIONS CAREFULLY BEFORE ATTEMPTING TO INSTALL, OPERATE OR SERVICE THIS WINCH. FAILURE TO COMPLY WITH INSTRUCTIONS COULD RESULT IN SERIOUS OR FATAL INJURY. RETAIN THESE INSTRUCTIONS FOR FUTURE REFERENCE.



IMPORTANT SAFETY INFORMATION

- This winch is built for multi-purpose hauling and pulling operations. It is not recommended for lifting applications. For lifting, use a self-locking winch. DL winches are not to be used as hoists for lifting, supporting or transporting people, or for loads over areas where people could be present.
- Respect this winch. High forces are created when using a winch, creating potential safety hazards. It should be operated and maintained in accordance with instructions. Never allow children or anyone who is not familiar with the operation of the winch to use it.
- Maintain a firm grip on the winch handle at all times, and never release the handle when ratchet lever is in unlocked position with a load on the winch. Otherwise, handle will spin violently, which could cause personal injury.
- Check for proper ratchet operation on each use of the winch. Do not use if damaged. Seek immediate repairs.
- Never use the winch handle as a convenient handle for pulling or maneuvering the entire trailer or other equipment. Never pull on the winch handle against a locked ratchet.
- Never exceed rated capacity. Excess load may cause premature failure and could result in serious personal injury. This winch is rated with three layers of line on the hub. Using more layers of line or a large hub increases the load on the winch.
- Never apply load on winch with cable or rope fully extended. Keep at least three full turns of cable or rope on the reel.
- Secure load properly. When winching operation is complete, do not depend on winch to support load.
- Operate with hand power only. This winch should not be operated with a motor of any kind. If the winch cannot be cranked easily with one hand, it is probably over-loaded.

WINCH MOUNTING AND CABLE ATTACHMENT – For maximum strength and safety, (and compliance with SAE Standard J1853) this winch should be mounted with three $\frac{3}{8}$ " or M10 bolts, washers, and lock washers. (See parts drawing).

Select a winch line with breaking strength at least 1-1/2 times the winch rating and a hook 1-1/2 times stronger than the line. If steel cable is selected, the optional reel with large hub may

extend cable life. (The above combination meets SAE Standard J1853 for boat trailer winches).

Attach cable or rope by either method described in sketch. If nylon strap is used, it should have a loop sewn in one end and be attached using a $\frac{3}{8}$ " x 3" long bolt and locknut. Use a locknut, not a nut and lockwasher. Insert bolt through slots in both reel sideplates so that nut is on gear side. Tighten only until snug with bolt in bottom of slot next to reel hub.

OPERATING INSTRUCTIONS – Attach winch handle securely to primary drive shaft (low speed shaft). Make sure that handle clip engages with groove in drive shaft. Wind line on winch reel by turning winch handle in clockwise direction with ratchet lever in up position. The ratchet should produce a loud, sharp clicking noise. Make sure that ratchet lever is in up position and holding load before winch handle is released. To unwind or reel out line, securely grip winch handle and apply force in clockwise direction so that ratchet lever can easily be moved to down position. Carefully turn handle in counterclockwise direction. Do not lose control. If handle is attached to direct drive-shaft (high speed shaft) operate as described above, reversing clockwise and counterclockwise. The winch can be converted to wind line on to the underside of the reel. To do this, carefully examine ratchet assembly and

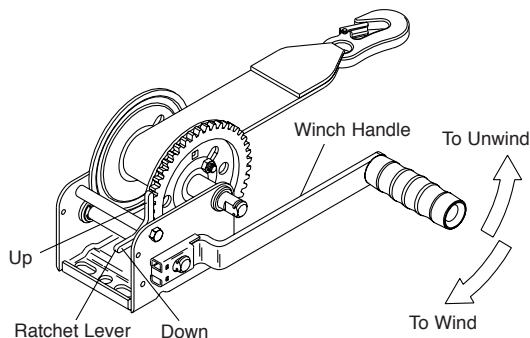

remove it from winch. Do not lose small parts. Turn the lever over and reassemble. Do not over tighten bolt. Check operation to insure the ratchet lever rotates fully without binding.

WINCH MAINTENANCE – This winch has been fully lubricated at the factory; but, for continued smooth performance and increased life, occasional greasing of gears and reel shaft and an occasional drop of oil on drive shaft bearings are recommended.

Keep winch in good working order. Damaged or severely-worn parts create unnecessary dangers and could result in personal injury or property damage.

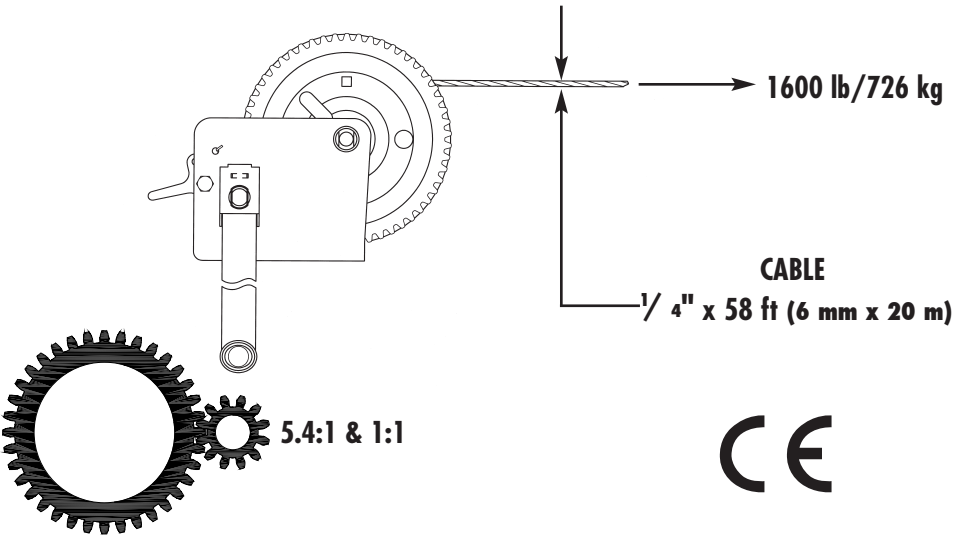

1600 lb/726 kg

CABLE

1/4" x 58 ft (6 mm x 20 m)

5.4:1 & 1:1





DL1602ADD

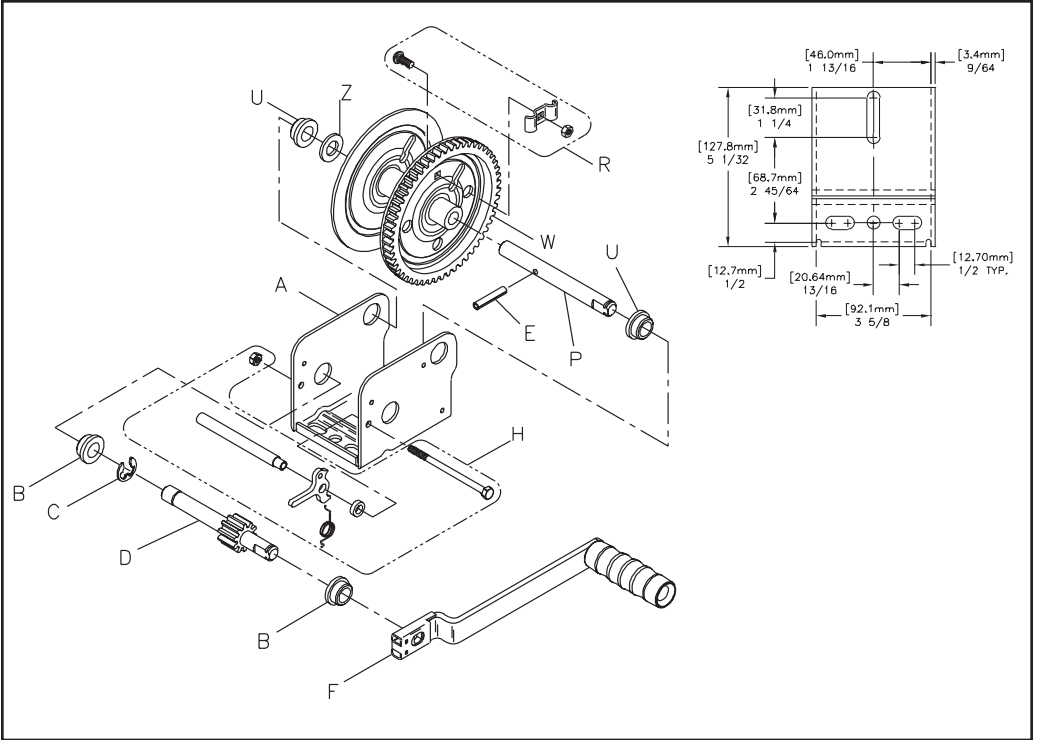

Ref	Description	Part No.
A	Base	404923*
B	Bushing (2)	204009
C	E-Ring	205116
D	Drive Shaft	304818
E	Pin	206042
F	Handle	5703301
H	Ratchet Kit DL1602ADD	5704556
P	Reel Shaft	404625
R	Rope Clamp Kit	5243506
U	Bushing (2)	206335
W	Reel (1-1/8" Hub)	304816*
W	Reel (2-1/2" Hub), Opt.	304817*
Z	Washer	205139

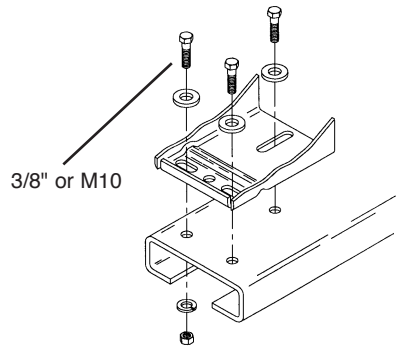

*Specify Color

