



PRO-X8MSIE

8" MIDRANGE LOUDSPEAKER WITH SEALED BACK

MAX Power Handling: 550 Watts

RMS Power Handling: 275 Watts

Frequency Response: 482Hz-11.5KHz

Voice Coil Material: Kapton

Voice Coil Diameter: 1.5" (38.1 mm)

Nominal Impedance: 8 ohms

Mounting Depth: 82 mm (3.23")

Sensitivity (1W/1M): 98.2dB

Magnet Material: Ferrite

Magnet Weight: 33 oz

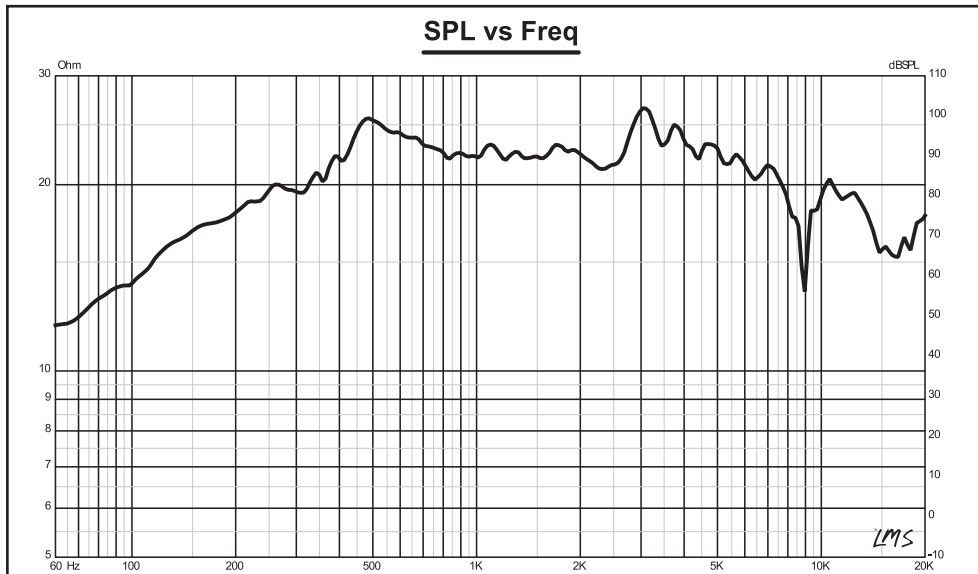

8"

MIDRANGE LOUDSPEAKER WITH SEALED BACK

PRO-X8MSIE

550W MAX

275W RMS

8 OHMS



OWNER'S MANUAL

PRO-X8MSIE

**8" MIDRANGE LOUDSPEAKER
WITH SEALED BACK**

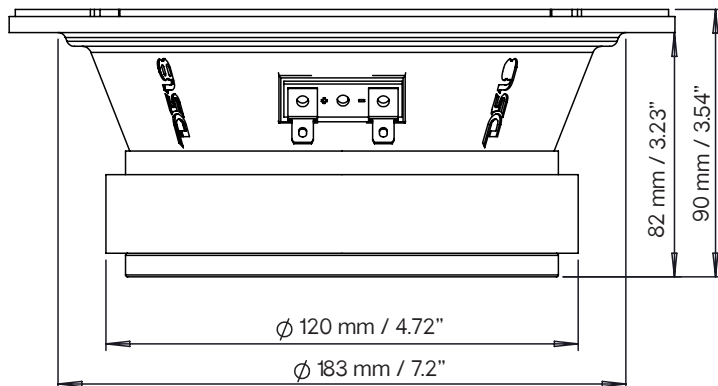
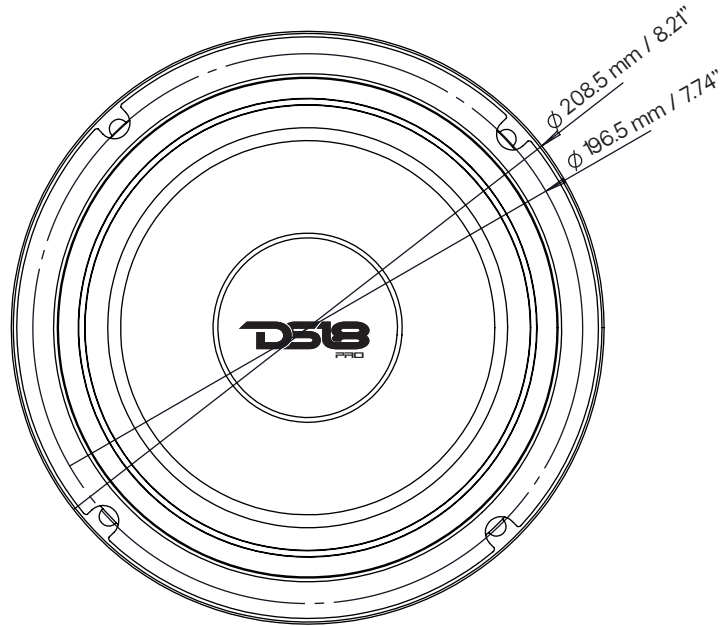

Data Sheet

Specifications:

Nominal Diameter	8" (203.2mm)
Nominal Impedance	8 ohms
RMS Power Handling	275 WATTS
Maximum Power Handling	550 WATTS
Sensitivity (1w/1m)	98.2dB
Frequency Response	482Hz-11.5KHz
Recommended Hi Pass Crossover	500 Hz

Midrange:

Voice Coil Diameter	1.5" (38.1 mm)
Voice Coil Former Material	Kapton
Winding Material	CCAW
Basket Material	Steel
Magnet Weight	33 oz

Thiele & Small Parameters:

Equivalent Volume	Vas	4.457 LTR
Excursion	Xmax	11 mm
Free Air Resonance	Fs	482Hz
Mechanical Factor	Qms	13.552
Electrical Factor	Qes	4.484
Total Factor	Qts	3.369
Dc Resistance	Re	5.2 ohms

Measurements:

Overall Diameter	208.5 mm (8.21")
Front Mount Baffle Cutout	183 mm (7.2")
Mounting Depth	82 mm (3.23")
Overall Depth	90 mm (3.54")

PRO-X8MSIE 8" MIDRANGE LOUD SPEAKER WITH SEALED BACK