

DS18[®]
PRO

PRO-FR69NEO
6X9" NEODYMIUM MID-RANGE
LOUDSPEAKER WITH BULLET

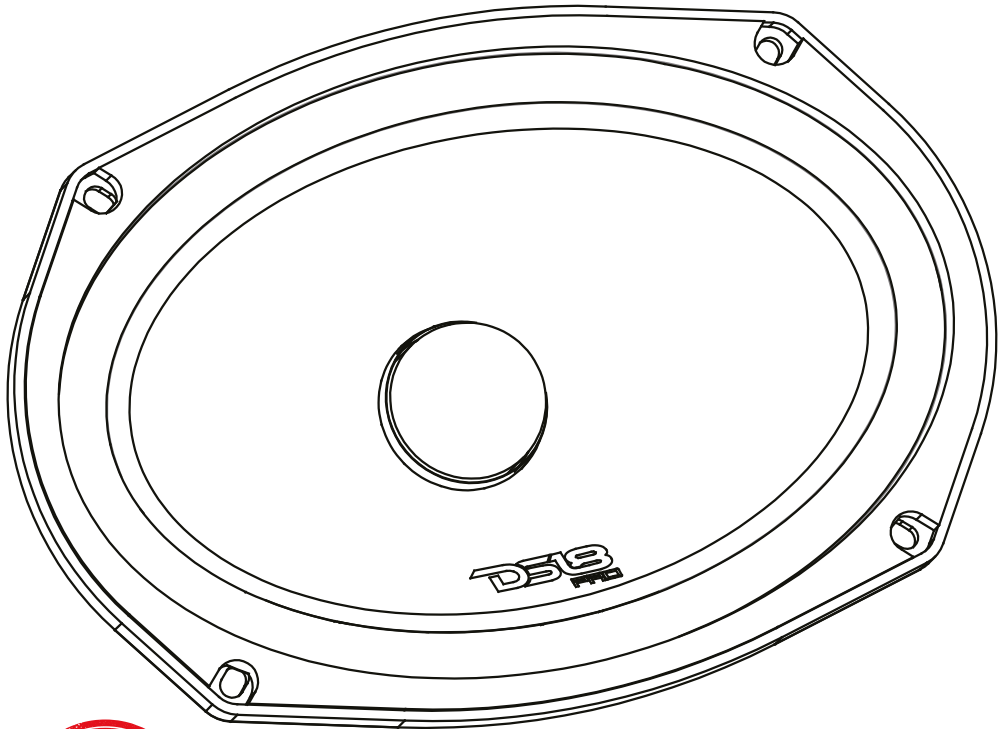

PRO-FR69NEO

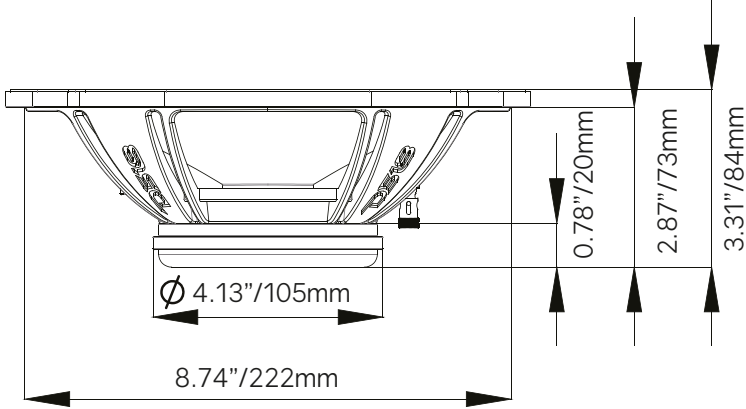
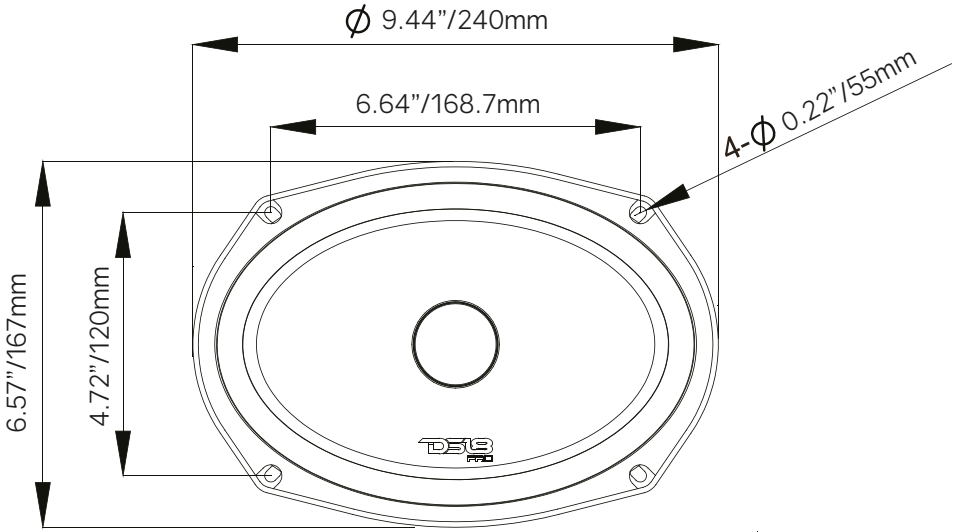

SPL vs Freq

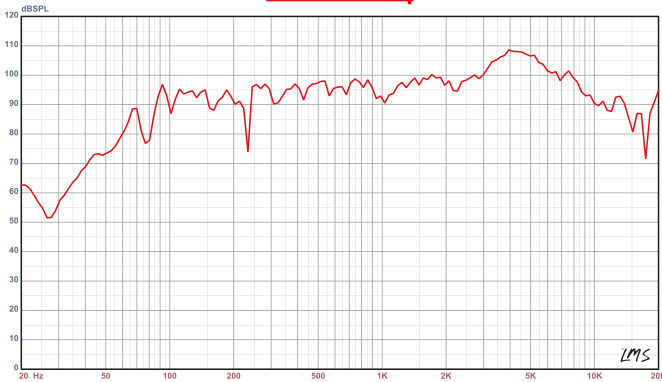



Specifications

Nominal Diamet.....	6x9"
Nominal Impedance	4 OHMS
RMS Power Handling	250w
MAX Power Handling	500w
Sensitivity (1w/1m)	98dB
Frequency Response.....	100Hz - 9KHz
Recommended HI Pass Crossover.....	120Hz

Motor

Voice Coil Diameter.....	38.6mm/1.5"
Voice Coil Former Material.....	Kapton
Winding Material.....	CCAW
Cone Material.....	Paper
Bullet Material.....	Aluminium
Surround Material.....	Cloth
Basket Material.....	Aluminium
Magnet Material.....	Neodymium
Magnet Weight.....	2.8Oz
Displacement Volume.....	0.0524L

Thiele & Small Parameters

Equivalent Volume	Vas.....	17.94Ltr
Excursion (one way)	Xmax.....	6.7mm
Free Air Resonance	Fs	109.95Hz
Mechanical Factor	Qms	7.471
Electrical Factor	Qes.....	0.297
Total Factor	Qts.....	0.286
Mechanical Mass	Mms.....	11.382g
Mechanical Compliance	Cms.....	279.513mm/N
BL Factor	BL.....	8.548
Voice Coil Inductance	Le.....	0.0425ohm
Cone Area	Sd.....	212.6mm ²
CD Resistance	Re.....	3.4 ohms
Mechanical Mass w/o air	Mmd.....	11.471g

Measurements

Overall Diameter.....	9.44X6.57" / 240X167mm
Overall Depth.....	3.31" / 84mm
Front Mount Baffle Cutout.....	8.74X5.97" / 222X152mm
Mouting Depth.....	2.874" / 73mm
Motor Diameter.....	4.13" / 105mm

PRO-FRAGENEO