

# DS18<sup>®</sup>

INFINITE

## BC200L PROCHARGER

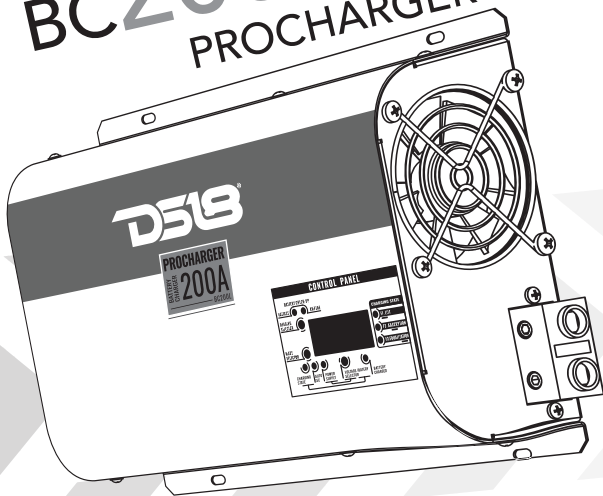

**OWNER'S MANUAL**

# BC200L BATTERY CHARGER

## SELECTION OF OPERATING MODES

The BC200L PROCHARGER is a high performance power supply that is capable to give you a maximum current of 200A and operate in 3 modes:

**Charging Stage Mode:** Charges the battery in 3 phases, (Elevation, Absorption, Equalization). Ideal for recharging the batteries when they are low, thus obtaining maximum efficiency without wearing, which increases the life of the battery.

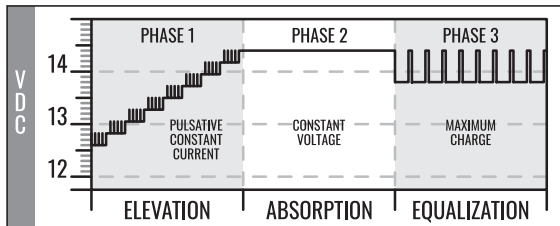

**Auto ICS Mode:** Mode to be used when the system is powered on or fast charged to the battery (s) as it will maintain maximum output power (14.4V) and enter the ICS pulsed system when the battery (s) are loaded and floating.

**Power Supply Mode:** Allows you to digitally choose 8 voltage values at the source output (12.6V / 12.8V / 13.0V / 13.2V / 13.8V / 14.0V / 14.2V / 14.4V).

## INFORMATION

### CHARGING STAGE MODE OPERATION:

1- Phase 1 (Elevation): Raises battery voltage up to 14.4V with maximum current of 20% of set battery nominal.

This phase has 8 steps which are indicated by the frequency of LED F1 from 1 to 8Hz. When the LED lights up constantly, this phase has already been executed.

2- Phase 2 (Absorption): The voltage is constant at 14.4, the battery absorbs charge and when the current decreases to 4% of the set battery nominal, led F2 lights up constantly, going to the next phase.

3- Phase 3 (Equalization): Phase 3 is characterized by decreasing the voltage to 13.8V with pulses of 14.4 every 5 minutes. The battery is charged to its maximum capacity because the equalization is done pulsatively.

**Conclusion:** The discharged battery is charged at 100% charge without heating, which will extend its life and make it possible to put more charge in it.

## SELECTION OF OPERATING MODES

### CHARGING STAGE MODE:

1- Press the MODE selector switch and select CHARGING STAGE

2- Press the BATTERY selector switch and select the ampere capacity of the battery to be charged. If there is more than one battery, add them all up and select the total capacity.

The options are as follows:

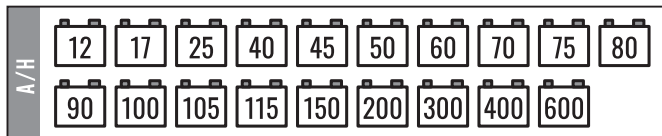

Note 1: If your battery does not fit these options, use the nearest value.

Note 2: If there is more than one source in the system, use only one in charging stage mode. All others should be turned off.

Note 3: When Full Charge is indicated, the battery is already charged.

F1, F2 and F3 indicate which stage is the charging process.

### AUTO ICS MODE:

Press the MODE selector switch and select Auto ICS (Intelligent Charge System).

Allows the power output to operate at 14.4V when the system requires more power. In float it operates with the output voltage in cycles of 13.8V for 5 minutes and 14.4V for 10 seconds. This system prevents the excessive potential of the plates, a chemical phenomenon caused by charge stress (electrolysis), increasing the battery life and efficiency.

### POWER SUPPLY MODE:

1- Press the MODE selector switch and select Output Voltage.

2- Press the Voltage selector switch and select the desired output voltage from the display:



## TABLE MODE / APPLICATION / ADVANTAGES

MODE	APPLICATION	ADVANTAGES
<b>CHARGING STAGE</b>	Charge low batteries Charge batteries 24h before shipments	Cold batteries in the charging process, So there is no wear. Longer life. Batteries with maximum charge and greater instant energy. Stronger bass.
<b>AUTO ICS</b>	When sound is on or the battery is quickly charged	Total power supply at 14.4V. Pulsing system between 13.8 and 14.4V with the sound off, equalizing the battery charge.
<b>POWER SUPPLY</b>	Systems without battery	You can choose an output voltage between 12.6 and 14.4Vdc to power the amplifier or other device.

## TYPES OF READING

**Voltage:** Informs the voltage sent to the system.

**Current:** Shows the current consumed by the system.

**Battery Check-Up:** Informs how much charge has been accumulated by the battery during the charging cycle, with this reading it is possible to know if the battery is in good working order.

The counter can be reset by holding the Read key for 5 seconds. Upon reaching 999 it must be reset to continue reading accumulated battery charge.

## IMPORTANT TIPS

1. Prioritize charging the batteries at a slow charge, thus accumulating more charge and extending the life of the battery.
2. If the batteries are discharged, charge only in charging stage mode, so that they will not wear out or overheat.
3. We advise that when using the sound, immediately turn on the PROCHARGER in AUTO ICS mode. Do not wait for the batteries to discharge before doing so.
4. Use 1 outlet per equipment. Each BC200L battery charger consumes about 3,000W in maximum capacity
5. Use 0 GA at 200A output.
6. Do not install in high vibration environments such as speakers boxes.

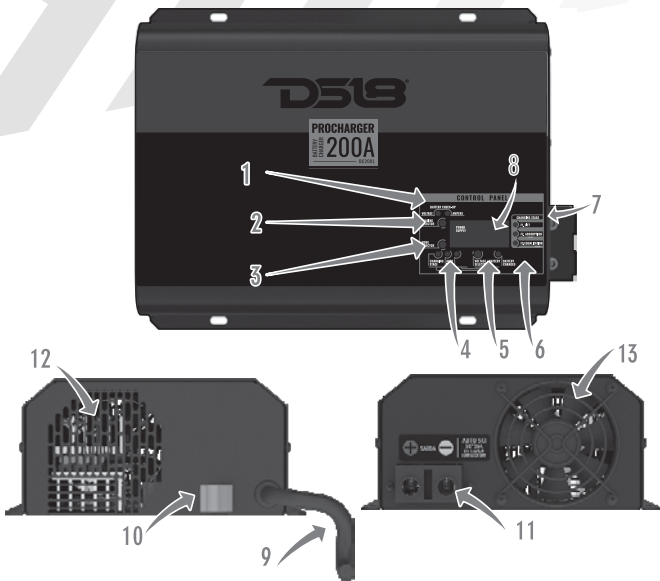

- 1- LEDs that indicate voltage or current monitoring or Check-up of the battery “2 LEDs access”
- 2- Voltage, Current and Ampere Hour reading mode selector switch
- 3- Charging Stage, Auto ICS and Power Supply selector switch
- 4- Leds indicators modes
- 5- Battery Capacity Selector Switch (Charging Stage Mode) or Output Voltage (Power Supply Mode)
- 6- Led full charge indicator
- 7- LEDs indicating the 3 stages of charging
- 8- Display of Voltage or Current indicator or Ampere Hour Counter
- 9- Power input cable
- 10- Circuit breaker acting as an on / off switch
- 11- output connector
- 12- Air outlet (never obstruct)
- 13- Air inlet (never obstruct)

**DIAGRAM OF CONNECTIONS**

Each BC200L battery charger can power about 10000 Watts of music power, using a parallel battery to supply peak consumption.

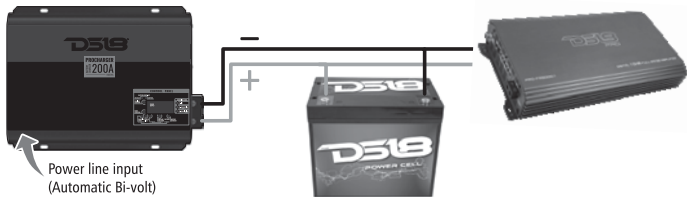

You can use as many BC200L PROCHARGERS as you need to power the sound, with a reference that each keeps about 10,000W RMS of sound playing and it is important to note that when operating at In parallel, the sources must operate in the same MODES as follows:

Auto SCI: All sources must be in SCI.

Power Supply: All sources must have the same output voltage.

Charging Stage: Only one procharger is on, the other prochargers must be off.

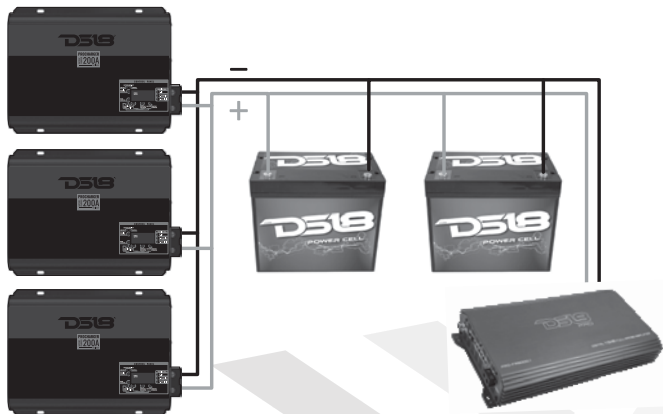

**TECHNICAL SPECIFICATIONS**

Input (Automatic Bi-volt)	90 to 140Vac / 170 to 240Vac
Consumption with maximum load	3000W
Maximum output current	200 Amperes
Maximum Output Voltage	14.4 Vdc
Intelligent charging system	13.8 / 14.4 Vdc cyclic
Accuracy Voltmeter / Amp Meter	99% / 96%
Refrigeration	Forced
Protections	Excess charge, short on output and temperature
Dimensions L x W x D (mm)	295 x 190 x 90 mm/10.19 x 7.48 x 3.54 in
Weight kg	2.750

**SERVICE WARRANTY**

Should your BC200L require service please consult with the dealer from which it was purchased, or DS18 Local Dealer.

Do not attempt to return your BC200L directly to us without first calling for a Return Authorization Number.

Units received without an accompanying Return Authorization Number will be processed slower. Additionally, you must include a copy of your purchase receipt from an authorized dealer for consideration of in-warranty service; otherwise repair charges will apply. Units received without a receipt will be held for 30 days, all units will be returned to you, unrepared.



# DS18<sup>®</sup>

INFINITE

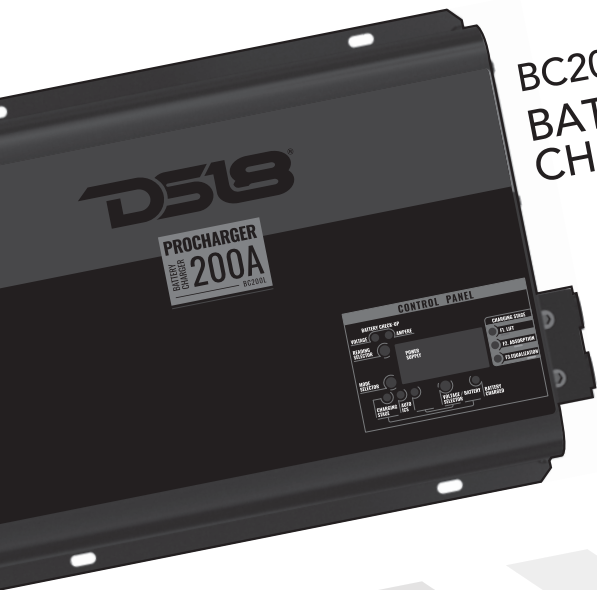

BC200L  
BATTERY  
CHARGER

Check out the collection of batteries & power sources we offer.