

Installation Instructions

Part Numbers:

Nissan Juke AWD

24867

60284

77248

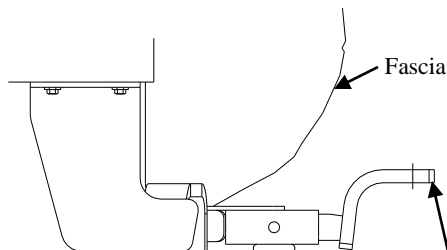

Drawbar Kit:

3593

Drawbar must be used in the **Rise** position only.

**Do Not Exceed Lower of Towing Vehicle
Manufacturer's Rating or**

2000 LB (908 Kg) Max Gross Trailer Weight

200 LB (90.8 Kg) Max Tongue Weight

Hitch Shown In Proper Position

Equipment Required: Lubricant or Soapy water

Fastener Kit: 24867F

Wrenches: 17mm, 18mm, 19mm and 6" extension

Wiring Access Location: SUV 3, 4

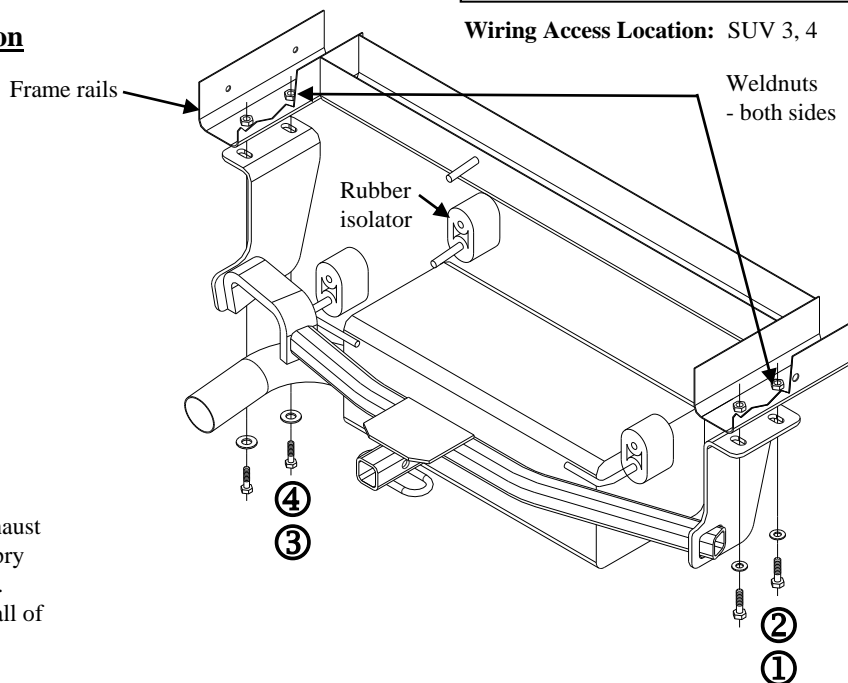

Spray some lubricant on the rubber exhaust hangers and then use a screwdriver or pry bar to remove all of the rubber hangers. Support the system while you remove all of the hangers

①	Qty. (2)	Hex bolt M12 X 1.25 X 35mm CL8.8	③	Qty. (2)	Hex bolt M10 X 1.25 X 30mm CL8.8
②	Qty. (2)	1/2" Conical washer	④	Qty. (2)	3/8" Conical washer

1. Remove and return factory tow hook and fasteners to vehicle owner. (4 Bolts)
2. Lower exhaust system at the rubber isolator (3 places) leaving the rubber isolator attached to muffler. Note: Spraying a lubricant or soapy water on the metal hanger rod and the rubber isolator helps removal. Be careful not to allow muffler to fall under its own weight.
3. Scrape undercoating and caulking from bottom of frame rails large enough to allow the hitch brackets to sit flush against the frame rails. Clean out undercoating from weldnut (do not damage threads). Confirm M10 hex bolt will thread into weldnuts.
4. Raise hitch into position on driver's side and loosely install fastener as shown, installing a hex bolt and conical washer thru elongated hole in hitch into vehicle frame. Raise hitch into position on passenger's side and loosely install fastener as shown, installing hex bolt and conical washer thru elongated hole in hitch into vehicle frame. Center hitch on vehicle and install remaining hardware as shown.
5. Tighten all fasteners to the required torque specification.
6. Reinstall exhaust.

Tighten all M10 CL 8.8 fasteners with torque wrench to 39 Lb.-Ft. (52 N*M)

Tighten all M12 CL 8.8 fasteners with torque wrench to 68 Lb.-Ft. (92 N*M)

Note: check hitch frequently, making sure all fasteners and ball are properly tightened. If hitch is removed, plug all holes in trunk pan or other body panels to prevent entry of water and exhaust fumes. A hitch or ball which has been damaged should be removed and replaced. Observe safety precautions when working beneath a vehicle and wear eye protection. Do not cut access or attachment holes with a torch.

Looking for dependable trailer hitches and towing? Rely on Draw-Tite for quality and long-lasting products.