

Installation Instructions

Part Numbers:

75866

87652

44703

Chevrolet Silverado Pickup 1500 GMC Sierra Pickup 1500 (Requires OEM Bumper)

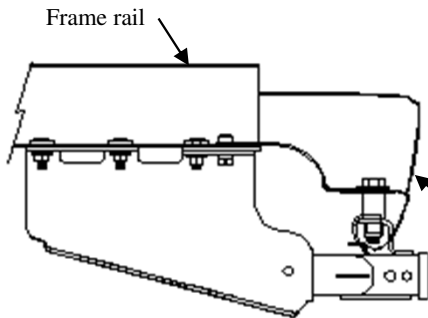

Hitch Shown In Proper Position

Equipment Required:

Fastener Kit: 75866F

Wrenches: 3/4, 22mm, 21mm 1-1/8" open end wrench, & 1-1/8"

Drill Bits: None

Note : Factory installed steel step bumper and brackets must be used in conjunction with this hitch

**Do Not Exceed Lower of Towing Vehicle
Manufacturer's Rating or**

Hitch type	Max Gross Trailer WT (LB)	Max Tongue WT (LB)
Weight Distributing	12,000 (5448 Kg)	1200 (545 Kg)
Weight Carrying Ball Mount	6000 (2724 Kg)	900 (409 Kg)

Wiring Access Location: PU3

Accessory Rating

E

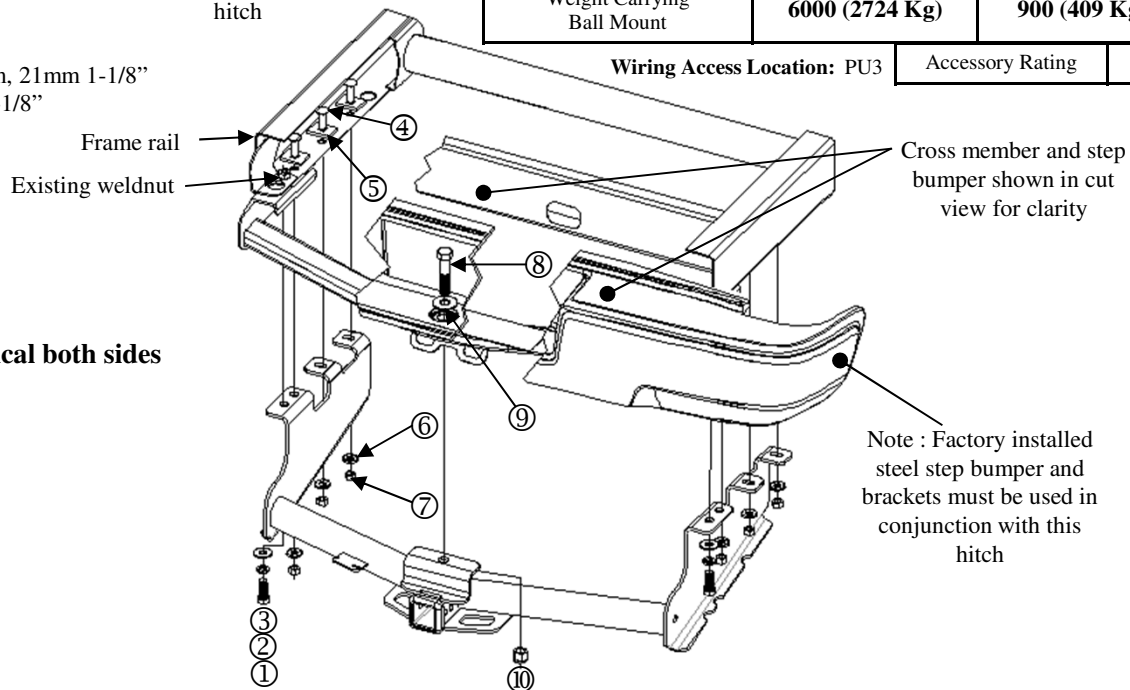

Note: Fasteners typical both sides

Note : Factory installed steel step bumper and brackets must be used in conjunction with this hitch

①	Qty. (2)	Hex bolt M14 X 2.0 X 40mm CL 10.9	⑥	Qty. (6)	Conical washer 1/2"
②	Qty. (2)	Lock washer 9/16"	⑦	Qty. (6)	Hex nut 1/2-13
③	Qty. (2)	Flat washer 9/16"	⑧	Qty. (1)	Hex bolt 3/4-10 X 3.50 GR5
④	Qty. (6)	Carriage bolt 1/2-13 X 1-3/4" GR5	⑨	Qty. (1)	Conical washer 3/4"
⑤	Qty. (6)	Spacer	⑩	Qty. (1)	Hex nut 3/4-10

Fasteners Typical Both Sides of Vehicle

Note: Factory Installed Steel Step Bumper and Brackets Must Be Used In Conjunction with Hitch

Note: Loosen the spare tire for ease of installment

1. Remove or trim out the cap in the step bumper.
2. Remove existing M14 bolts from end of each frame rail.
3. Lift hitch into position, locating rearmost holes in hitch under existing weldnuts in vehicle frame.
4. Install M14 bolts and conical washer, into weldnuts in vehicle frame at the step bumper attachment.
5. Install remaining fasteners as shown.
6. Tighten all fasteners to the required torque specification.
7. Re-tighten the spare tire

Tighten all 1/2-13 GR5 fasteners with torque wrench to 75 Lb.-Ft. (102 N*M)
Tighten all M14 CL10.9 fasteners with torque wrench to 100 Lb.-Ft. (136 N*M)
Tighten all 3/4-10 GR 5 fasteners with torque wrench to 260 Lb.-Ft. (353 N*M)

Note: check hitch frequently, making sure all fasteners and ball are properly tightened. If hitch is removed, plug all holes in trunk pan or other body panels to prevent entry of water and exhaust fumes. A hitch or ball which has been damaged should be removed and replaced. Observe safety precautions when working beneath a vehicle and wear eye protection. Do not cut access or attachment holes with a torch.