

# Installation Instructions

**Mercedes GLK350**

All Models including 4-Matic & RWD

Part Numbers:

**75774, 87636**

**44690, 78303 U-Haul**

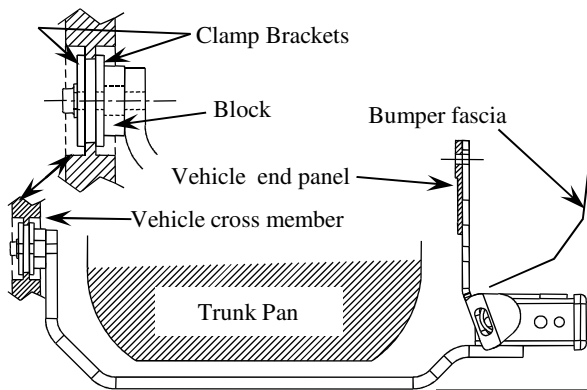

**Do Not Exceed Lower of Towing Vehicle Manufacturer's Rating or**

Hitch type	Max Gross Trailer WT (LB)	Max Tongue WT (LB)
Weight Carrying Ball Mount	<b>4000 (1814 Kg)</b>	<b>600 (272 Kg)</b>

**Wiring Access Location:** SUV 3, SUV 4

## Hitch Shown In Proper Position

### Equipment Required:

**Fastener Kit:** 75774F

**Wrenches:** 3/4", 7/8"

**Drill Bits:** None

**Other Tools:** Tape

**RWD Models-Note!** You may have to insert the clamp bracket with nuts through the crossmember opening from the rearward side and locate on forward side of crossmember.

**Offset hole towards passenger's side of vehicle**

**Vehicle frame cross member**

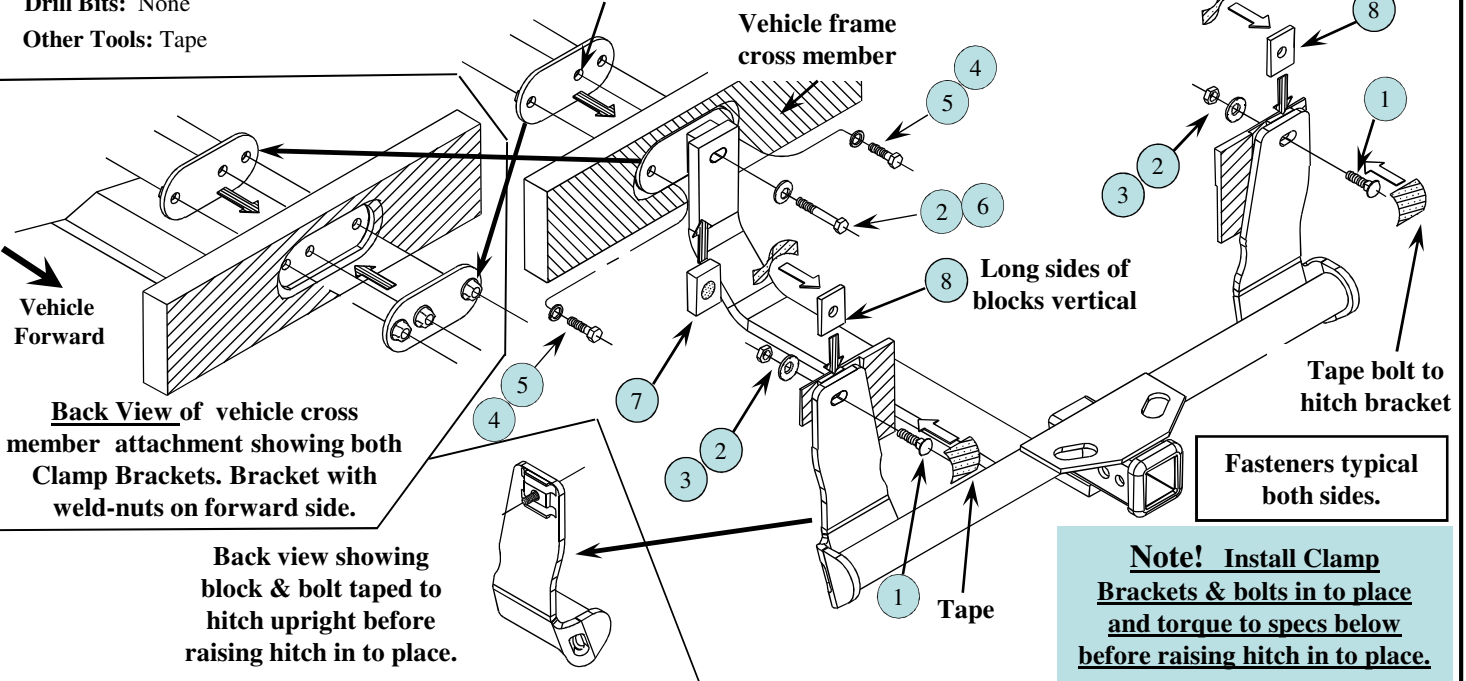

1	Qty. (2)	1/2"-13 X 1-1/2" Gr.5 Carriage Bolt	5	Qty. (2)	1/2" Lock Washer
2	Qty. (3)	1/2" Conical Toothed Washer	6	Qty. (1)	1/2-13 X 3" Gr.5 Hex Bolt
3	Qty. (2)	1/2"-13 Hex Nut	7	Qty. (1)	5/8" X 1-1/2" X 2" Block
4	Qty. (2)	1/2"-13 X 1-1/2" Gr.5 Hex Bolt	8	Qty. (2)	1/4" X 1-1/2" X 2" Block

1. You may have to remove or bend up small plastic fascia tabs sticking out on bottom of bumper fascia before installing hitch. See picture next page.
2. Install Clamp Brackets to vehicle cross member and install bolts and lock washers and torque to specs below before installing hitch. Bracket with weld-nuts goes on forward side of cross member. Be sure to orient offset hole to vehicle passenger's side as shown. See picture next page. See note above regarding RWD models.
3. Tape blocks and bolts to hitch uprights as shown before raising hitch in to place as shown above. Blocks should be positioned with long sides vertical.
4. Raise hitch up under vehicle being careful not to push bolts out of hitch that are taped in to place. Install conical washer & nuts loosely to hold hitch in place. Rotate hitch and insert 5/8" thick block between hitch bar & clamp bracket and install 3" long hex bolt and conical washer. Torque 3" long bolt to specs below. Torque (2) rearward 1/2" nuts to specs below.

Tighten 1/2"-13 Gr.5 bolts /nuts with torque wrench to 75Lb.-Ft. (102 N\*M).

# Installation Instructions

**Mercedes GLK350**

All Models including 4-Matic & RWD

Part Numbers:

**75774, 87636**

**44690, 78303 U-Haul**

## View of Clamp Brackets in place

Looking forward on vehicle showing bolts and lock washers in place. Make sure brackets are vertical inside of cross member depression and then torque to 75ft. lbs. before raising hitch up under vehicle.



## View of bumper fascia tab

Bend up or remove before installing hitch.

