

Part Numbers:

75761

87630

44684

75366 U-HAUL

Installation Instructions

BMW X1

Only fits vehicles with Panoramic Moonroof

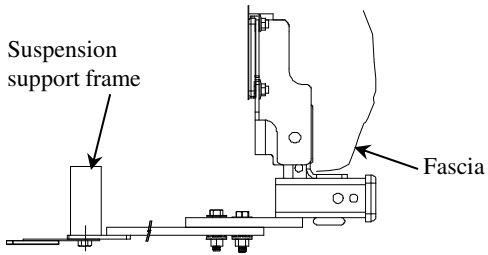

**Do Not Exceed Lower of Towing Vehicle
Manufacturer's Rating or**

| Hitch type | Max Gross Trailer WT (LB) | Max Tongue WT (LB) |
|----------------------------|---------------------------|---------------------|
| Weight Distributing | 4000 (1816 Kg) | 400 (182 Kg) |
| Weight Carrying Ball Mount | 3500 (1589 Kg) | 400 (182 Kg) |

Hitch Shown In Proper Position

Equipment Required: Rivet gun, screwdriver or trim tool, small punch.

Fastener Kit: 75761F

Wrenches: 8mm, 10mm, 18mm, & (2) 3/4"

Drill Bits: NONE

Wiring Access Location: SUV1 & 2

Accessory Rating **C**

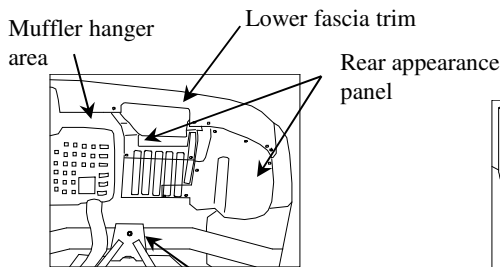

Figure 1. Suspension support frame

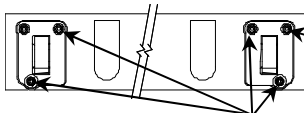

Figure 2. Remove (4) flange nuts.

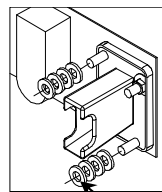

Figure 3.

Note: Loosen existing nut for ease of installation.

Note: Fasteners typical both sides

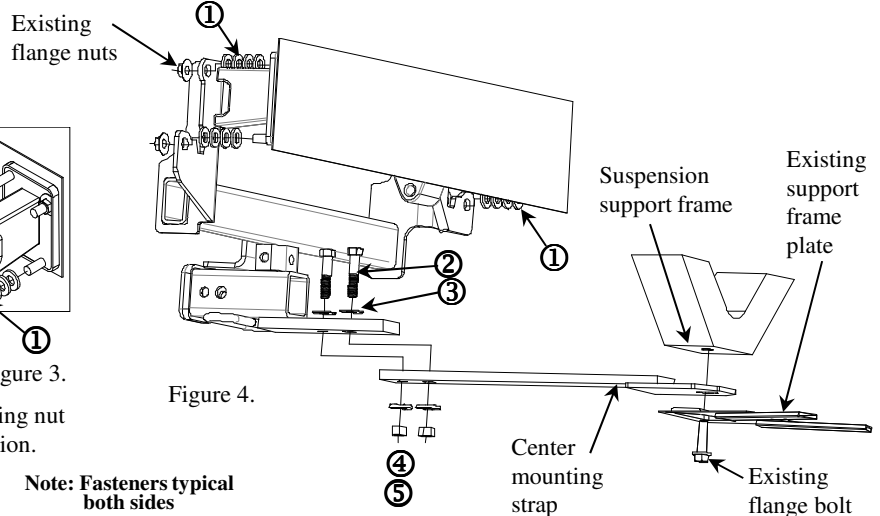

Figure 4.

| | | | | | |
|---|-----------|-------------------------|---|----------|------------------|
| ① | Qty. (16) | Washer 1/2" | ④ | Qty. (2) | Hex nut 1/2-13 |
| ② | Qty. (2) | Bolts 1/2-13 X 2.25 GR5 | ⑤ | Qty. (2) | Flat washer 1/2" |
| ③ | Qty. (2) | Conical washer 1/2" | ⑥ | Qty. (2) | Plastic rivets |

Note: if vehicle is equipped disconnect the back up sensors during installation.

- Remove lower fascia trim on the rear of the vehicle by removing the (5) fasteners and (2) plastic rivets that secure the bottom fascia to the vehicle. Punch out the center of the rivets head by using a small punch or blunt nail. Carefully slide screwdriver or trim panel tool between the panels covering to loosen rivets, and remove remaining rivet head. Working your way from outside (rivet location), slowly pull up fascia trim.
- Remove or loosen the (2) rear appearance panels on the bottom of the vehicle for additional clearance during hitch installation if necessary.
- Remove the inside muffler hanger using a 10mm socket.
- Remove the (4) flange nuts from the bumper. See Figure 2.
- Place (item 1) (4) flat washer onto each studs as shown. See Figure 3. Both sides.
- Lift the hitch into position onto the studs on the driver's side first, going over the exhaust taking extreme caution around ECV valve if present.
- Swing the hitch into place and re-install the existing M12 flange nuts.
- Remove the bolt from the suspension support frame. Slide the center mounting strap between the support and existing plate. Re-install existing M12 bolt as shown.
- Attach the center support bar to the hitch as shown in figure 4.
- Reattach exhaust hanger bolt.
- Reinstall the (2) underbody appearance panels.
- Tighten all fasteners to the required torque specification.
- Reinstall the rear fascia appearance panel. Using the plastic rivets provided

Tighten all M12 fasteners with torque wrench to 68 Lb.-Ft. (92 N*M)
Tighten all 1/2-13 fasteners with torque wrench to 75Lb.-Ft. (102 N*M)

Cequent

