

Installation Instructions

Ford Escape (Includes Hybrid)
Mercury Mariner (Includes Hybrid)
Mazda Tribute

Part Numbers:
75751
87626
44680

**Do Not Exceed Lower of Towing Vehicle
 Manufacturer's Rating or**

Hitch type	Max Gross Trailer WT (LB)	Max Tongue WT (LB)
Weight Distributing	5250 (2383 Kg)	525 (239 Kg)
Weight Carrying Ball Mount	3500 (1589 Kg)	525 (239 Kg)

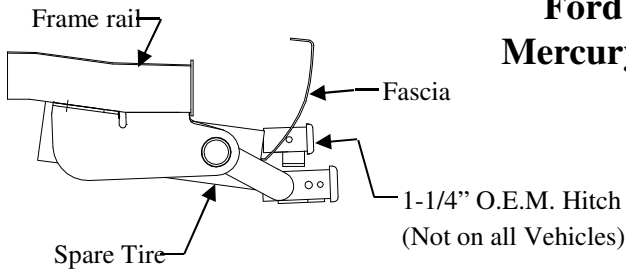

Hitch Shown In Proper Position

Equipment Required: Pullwires (provided)

Fastener Kit: 75751F

Wrenches: 10mm, 18mm, 22mm 5/8"

Drill Bits: none

Wiring Access Location: SUV1, SUV2

WARNING: If vehicle is equipped with O.E.M. hitch **DO NOT** use both Hitches at the same time. This may overload and cause damage to vehicle.

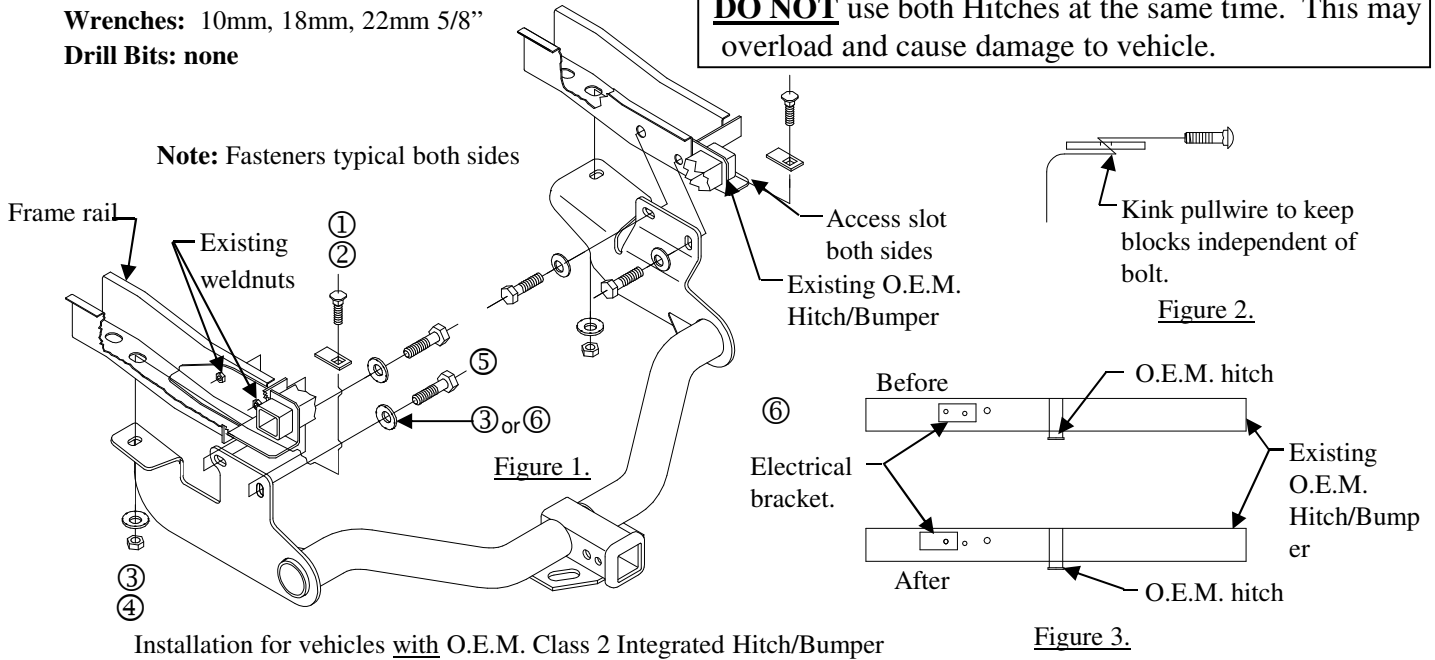

Installation for vehicles with O.E.M. Class 2 Integrated Hitch/Bumper

Figure 3.

①	Qty. (6)	Carriage Bolt 7/16 -14 X 1.75 GR5	④	Qty. (6)	Hex Nut 7/16 - 14
②	Qty. (6)	Block	⑤	Qty. (4)	Bolt M12 X 1.75 X 45 CL10.9 OR M14 X 2.0 X 45 CL10.9
③	Qty. (6)	Conical Washer 7/16"	⑥	Qty. (4)	Conical washer 5/8"

Installation for vehicles with O.E.M. Class 2 Integrated Hitch/Bumper. (Figure 1) – Without O.E.M. hitch, see next page (figure 4)

1. Remove existing bolts from inside frame rails. Return to owner.
2. Relocate existing electrical bracket. Remove (2) screws and shift the bracket toward the drivers side using the inside screw hole on bracket and outside weld nut (See Figure 3).
3. Raise hitch into position and install conical toothed washers and hex bolts into the existing weldnuts.
4. Using the pullwire feed carriage bolts and blocks thru access slot in end of the frame as shown in Figure 1. Using the kink pullwire to keep block independent of bolt (See Figure 2). Feed the pullwire thru the existing slot and hitch.
5. Attach conical toothed washer and hex nuts.

Note: Do Not use both Hitches at the same time. This may overload and cause damage to vehicle.

Tighten all M12 CL10.9 fasteners with torque wrench to 75 Lb.-Ft. (102 N*M)

Tighten all M14 CL10.9 fasteners with torque wrench to 115 Lb.-Ft. (156 N*M)

Tighten all 7/16 - 14 GR5 fasteners with torque wrench to 50 Lb.-Ft. (68 N*M)

Installation Instructions

Ford Escape, (Includes Hybrid)
Mercury Mariner, (Includes Hybrid)
Mazda Tribute

Part Numbers:
75751
87626
44680

Note: Do Not use both Hitches at the same time.
This may overload and cause damage to vehicle.

WARNING: If vehicle is equipped with O.E.M. hitch. **DO NOT** use both Hitches at the same time. This may overload and cause damage to vehicle.

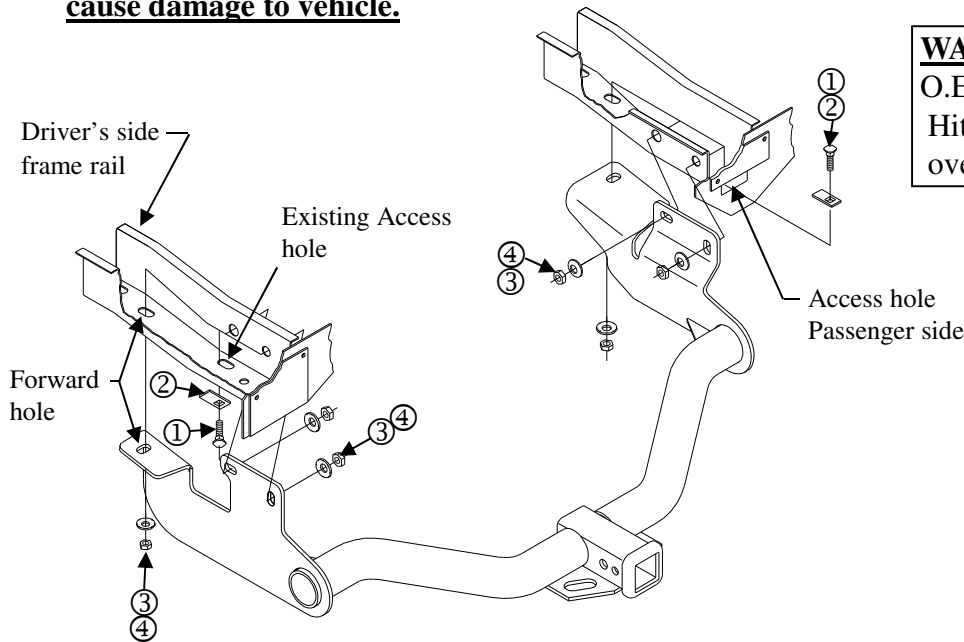

Note: Fasteners typical both sides

Figure 4.

Optional Installation Without existing O.E.M. Class 2 Integrated Hitch/Bumper. See previous page for vehicles with O.E.M. hitch

①	Qty. (6)	Carriage Bolt 7/16 – 14 X 1.75 GR5	④	Qty. (6)	Hex Nut 7/16 - 14
②	Qty. (6)	Block	⑤	Qty. (4)	Bolt M12 X 1.75 X 45 CL10.9
③	Qty. (6)	Conical Washer			

1. Use pullwire to feed 7/16 - 14 carriage bolt and block using the kink pullwire method (Figure 2) into the forward hole, using the access hole on the passengers frame rail. (See Figure 4)
2. Use the pullwire to feed 7/16 - 14 carriage bolt and block into the forward drivers frame rail using existing access hole. (As shown (Figure. 4))

Note: be careful not to push fasteners back into frame.

3. Raise hitch into position and onto carriage bolts and attach with conical toothed washers and nuts. Hand tighten the fasteners.
4. Use pullwire on remaining 7/16 – 14 carriage bolts and blocks into each frame rail (2 each side) using the same access holes as in Step 1 & 2. (See Figure 4)

Tighten all M12 CL10.9 fasteners with torque wrench to 75 Lb.-Ft. (102 N*M)

Tighten all 7/16 - 14 GR5 fasteners with torque wrench to 50 Lb.-Ft. (68 N*M)