

Installation Instructions

Part Numbers:

Volkswagen Tiguan

75658

Note: Fascia Trimming Required. Obtain Vehicle Owner's Approval Before Cutting

44611

87600

Do Not Exceed Lower of Towing Vehicle Manufacturer's Rating or

Hitch type	Max Gross Trailer WT (LB)	Max Tongue WT (LB)
Weight Distributing	Do Not Use With Spring Bars	
Weight Carrying Ball Mount	3500 (1589 Kg)	350 (159 Kg)

Wiring Access Location: PC1, PC2

Hitch Shown In Proper Position

Equipment Required: Utility Knife

Fastener Kit: 75658F

Wrenches: 17mm

Drill Bits: None

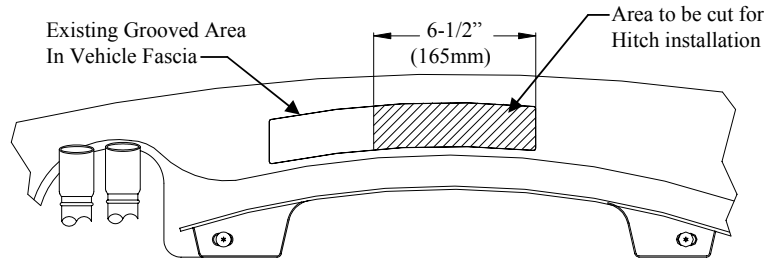

Figure 2 (Looking up from under vehicle)
Fascia trimming diagram

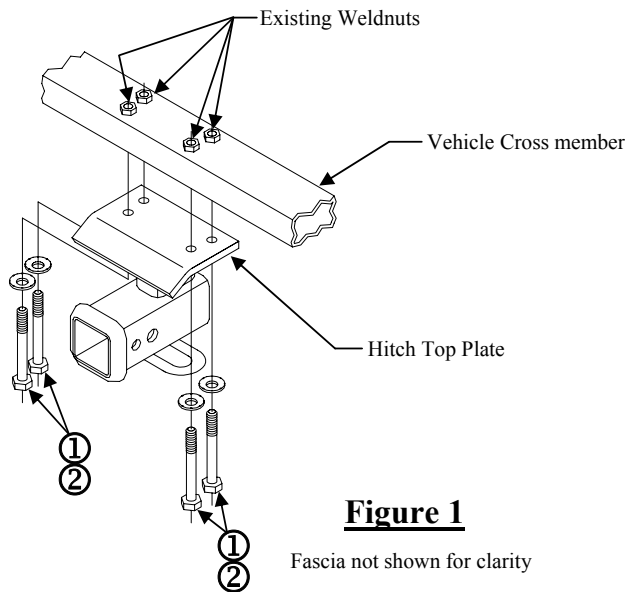

Figure 1

Fascia not shown for clarity

①	Qty. (4)	Hex Bolt M10 x 1.50 x 70mm CL8.8	②	Qty. (4)	Conical Toothed Washer 3/8"
---	----------	----------------------------------	---	----------	-----------------------------

Note: Fascia Trimming Required. Obtain Vehicle Owner's Approval Before Cutting.

1. Locate existing grooved area on bottom of fascia to be cut as shown in Figure 2. Cut fascia as shown to access mounting holes in vehicle cross member.
2. Raise hitch into position, aligning holes in hitch top plate with holes in vehicle cross member.
3. Secure with M10 x 1.50 x 70mm hex bolts and 3/8" conical toothed washers.

Cequent

Tighten all M10 CL8.8 fasteners with torque wrench to 38 Lb.-Ft. (52 N*M)

