



# Installation Instructions

**PART NUMBERS: 75219, 87688, 44770**

### Applications:

Years	Make	Models
2015-Current*	Ram	ProMaster City

\*Visit our website for the most up to date information regarding application years and trim levels.







### Installation Time: **60 min.**

The time listed above is the average time for professional installers. If you do not feel comfortable performing this installation on your own or are in need of assistance, please contact a professional installer.



**Representative Vehicle Photo**

### Equipment Required:

 Safety Glasses	 Ratchet	 15mm Sockets	 Torque Wrench	 12" Socket Extension
 T27 Torxbit Socket	 Philips Screwdriver			

### DO NOT EXCEED LOWER OF TOWING VEHICLE MANUFACTURER'S RATING OR:

Hitch Type	Max Gross Trailer Weight	Max Tongue Weight
Weight Carrying	3500 lb. (1589 kg)	350 lb. (159 kg)
Weight Distributing	N/A	N/A

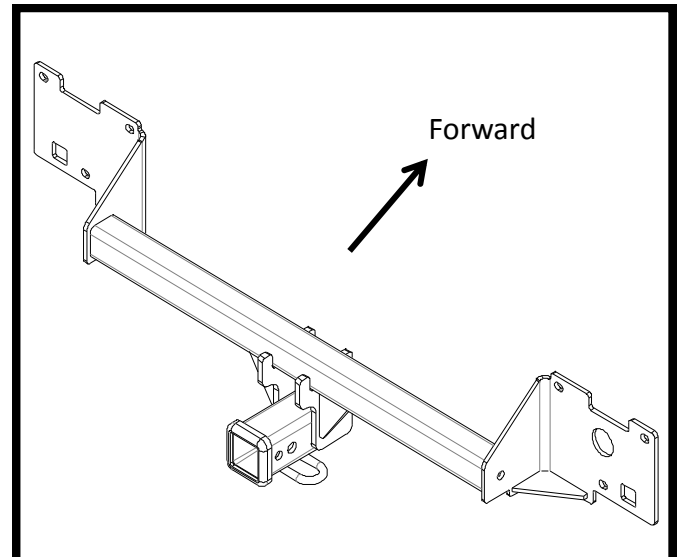

**Hitch Illustration**



Always wear SAFETY GLASSES  
when installing hitch

# Installation Instructions

PART NUMBERS: 75219, 87688, 44770

## FASTENERS TYPICAL ON BOTH SIDES

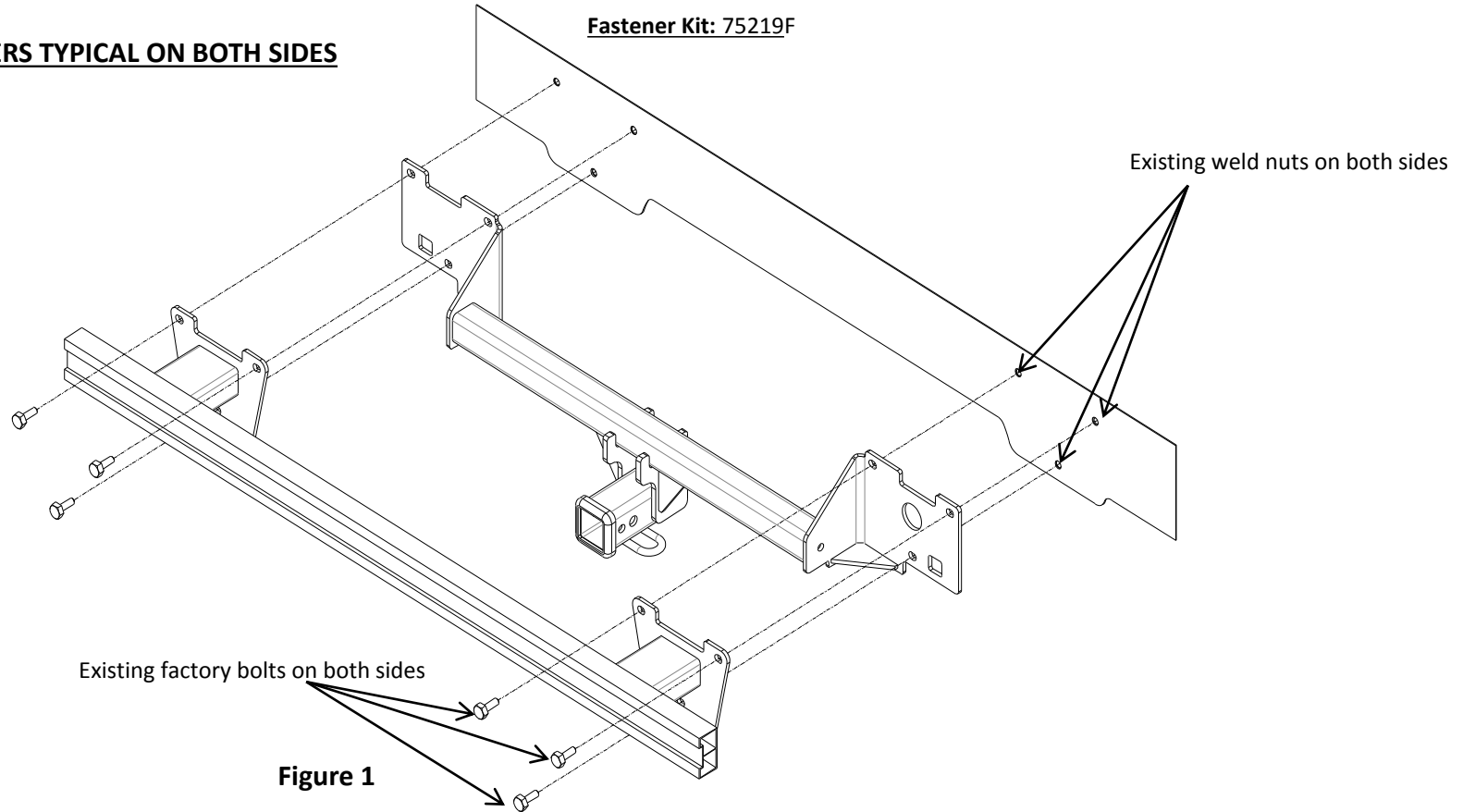

1. Remove (3) bottom bumper cover fasteners with a T27 torxbit socket and (10) wheel well fasteners with a phillips screwdriver.
2. Remove (2) fasteners located at the top of the bumper cover hidden behind the wheel well with a T27 torxbit socket.
3. Remove (4) top bumper cover fasteners with a T27 torxbit socket and (6) taillight fasteners with a phillips screwdriver.
4. Remove (2) final bumper cover fasteners below the taillight with a T27 torxbit socket.
5. Gently pull away the sides of the bumper cover until it detaches from vehicle. Disconnect the harness at the bumper, and put the bumper cover aside.
6. Remove (6) bumper bolts with a 15mm socket and put the bumper aside.
7. Raise the hitch into position, sandwich the hitch between the frame and the bumper, and loosely install the factory bolts.
8. Tighten all M10 fasteners to 42 lb-ft. **Proper torque is needed to keep the hitch secure to the vehicle when towing.**
9. Reinstall the bumper cover, harness and taillights in reverse order.

Note: Check hitch frequently, making sure all fasteners and ball are properly tightened. If hitch is removed, plug all holes in trunk pan or other body panels to prevent entry of water and exhaust fumes. A hitch or ball which has been damaged should be removed and replaced. Observe safety precautions when working beneath a vehicle and wear eye protection. Do not cut access or attachment holes with a torch.

This product complies with safety specifications and requirements for connecting devices and towing systems of the state of New York, V.E.S.C. Regulation V-5 and SAE J684.

1. Remove (3) bottom bumper cover fasteners with a T27 torxbit socket and (10) wheel well fasteners with a phillips screwdriver.



2. Remove (2) fasteners located at the top of the bumper cover hidden behind the wheel well with a T27 torxbit socket.



3. Remove (4) top bumper cover fasteners with a T27 torxbit socket and (6) taillight fasteners with a phillips screwdriver.



4. Remove (2) final bumper cover fasteners below the taillight with a T27 torxbit socket.



5. Gently pull away the sides of the bumper cover until it detaches from vehicle. Disconnect the harness at the bumper, and put the bumper cover aside.



6. Remove (6) bolts with a 15mm socket and put the bumper aside.



7. Raise the hitch into position, sandwich the hitch between the frame and the bumper, and loosely install the factory bolts.

8. Tighten all M10 fasteners to 42 lb-ft.

**⚠ Proper torque is needed to keep the hitch secure to the vehicle when towing.**



9. Reinstall the bumper cover, harness and taillights in reverse order.

