

Front Mounted Receiver Installation Instructions

Part Numbers:

65028

**Chevrolet Silverado 2500/2500HD/3500 2 & 4WD, Suburban 2500 2 & 4WD
GMC Sierra 2500/2500HD/3500 2 & 4WD, Yukon XL 2500 2 & 4WD
(Vehicles With Amber Turn Signals)**

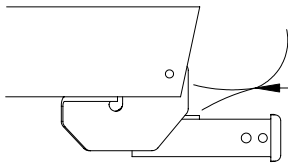

Fascia Has To Be Pushed Up 1-1/2" on 2002 And Later Vehicles

CARGO CAPACITY – DO NOT EXCEED 500 LB. OR VEHICLE FRONT GROSS AXLE WEIGHT RATING. (GAWR)	
9000	LB. MAX. WINCH LINE PULL

Receiver Shown In Proper Position

Hitch Requires 5/8" Pin and Clip

Equipment Required:

Fastener Kit: K65028

Wrenches: 3/4", 7/8", 18mm

Drill Bits: 9/16"

Pull Wire

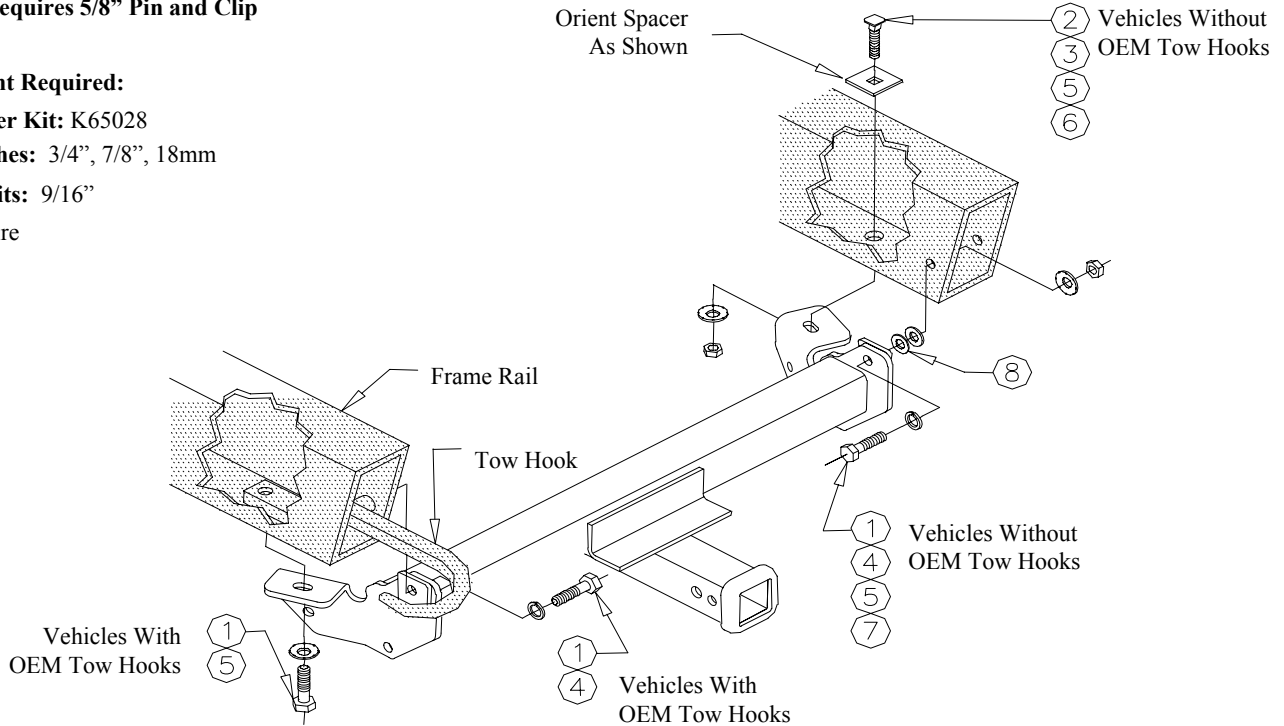

①	Qty. (4)	Hex Nut, M12 x 1.75 x 45	⑤	Qty. (4)	Conical Washer, 1/2"
②	Qty. (2)	Carriage Bolt, 1/2"-13 x 1-3/4"	⑥	Qty. (2)	Hex Nut, 1/2"
③	Qty. (2)	Spacer, 2" x 1.5" x 1/4"	⑦	Qty. (4)	Hex Nut, M12
④	Qty. (2)	Lock Washer, 1/2"	⑧	Qty. (2)	Flat Washer, 1/2"

1. If vehicle is equipped with OEM tow hooks remove tow hook fasteners from inside of frame and bottom of frame and return to vehicle owner.
2. Raise hitch into position and install fasteners as shown above. Use 1/2" flat washers as spacers between hitch and side of frame if necessary.
3. Due to variations in tow hook mounting holes, it may be necessary to enlarge 1/2" holes in hitch to 9/16" holes.

NOTE: Fascia trimming is optional on 2500 h.d./3500 models. CONSULT VEHICLE OWNER BEFORE TRIMMING.

Cequent



Tighten all 1/2" GR5 fasteners with torque wrench to 75 Lb.-Ft (102 N-m).
Tighten all M12 CL10.9 fasteners with torque wrench to 75 Lb.-Ft (102 N-m).