

Front Mounted Receiver Installation Instructions

Part Numbers:
65023

**Chevrolet Silverado Pickup, Suburban 1500 2 & 4WD, Tahoe 1500 2 & 4WD;
GMC Sierra Pickup, Yukon, & Yukon XL 1500 2 & 4WD
(Vehicles With Amber Turn Signals)
WILL NOT FIT 2500 SERIES**

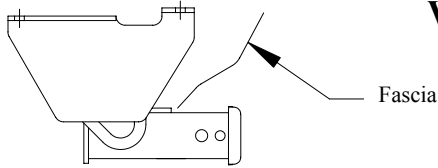

Fascia

Receiver Shown In Proper Position

**CARGO CAPACITY – DO NOT EXCEED
500 LB. OR VEHICLE FRONT GROSS
AXLE WEIGHT RATING. (GAWR)**

9000

LB. MAX. WINCH LINE PULL

Equipment Required:

Fastener Kit: 01131-133

Wrenches: 3/4", 18mm

Drill Bits: 1/2"

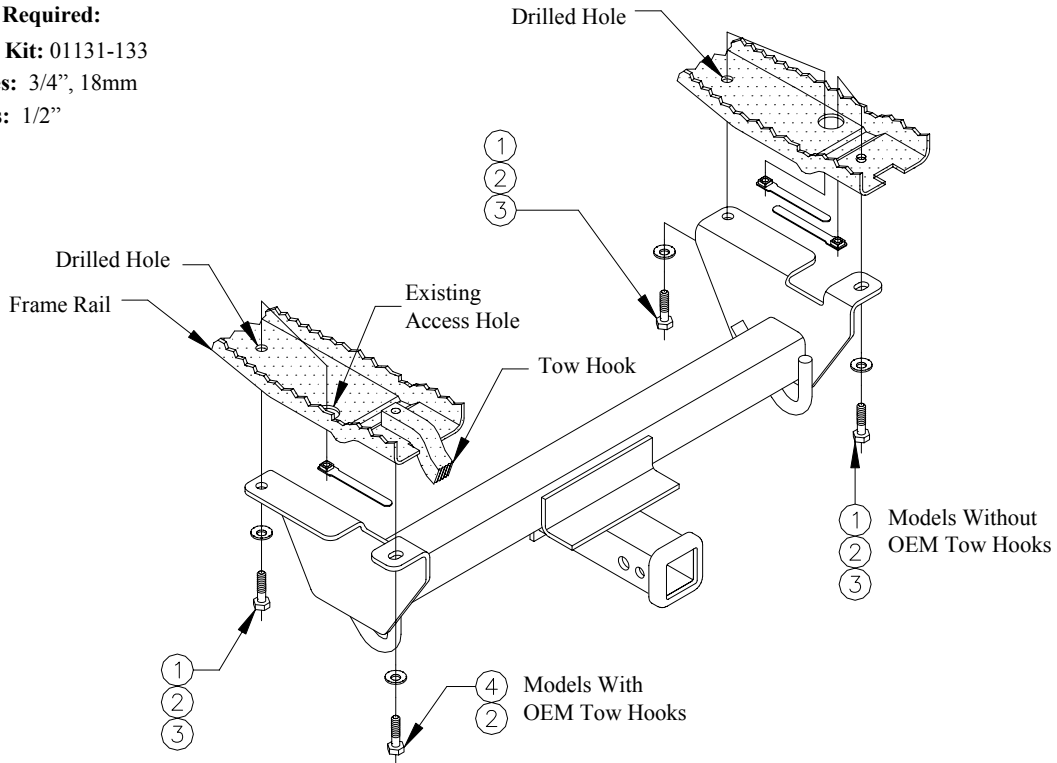

①	Qty. (4)	Hex Bolt, 1/2"-13 x 1-3/4"	③	Qty. (4)	Handle Nut, 1/2"
②	Qty. (4)	Conical Washer, 1/2"	④	Qty. (2)	Hex Bolt, M12 x 1.25 x 35

NOTE: On most 2006 Suburban and Yukon models, air dam must be trimmed. **CONSULT VEHICLE OWNER BEFORE TRIMMING.**

1. Remove the two (2) M12 fasteners from frame rails (for vehicles equipped with factory tow hooks).
2. Place hitch into position. For those models with OEM tow hooks secure with the provided M12 fasteners and washers. For models without tow hooks secure hitch with 1/2" fasteners, washers and handle nuts.
3. Using hitch as template drill two (2) 1/2" holes in frame rails.
4. Install remaining fasteners as shown.

Cequent



Tighten all 1/2" GR5 fasteners with torque wrench to 50 Lb.-Ft (68 N-m).
Tighten all M12 CL10.9 fasteners with torque wrench to 75 Lb.-Ft (102 N-m).