



Front Mounted Receiver Installation Instructions

***Ford Ranger, Ford Explorer**

***Mazda B-Series Truck, *Mazda Navajo**

****See Note Below and Figure 1**

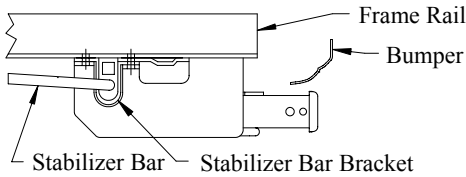

**CARGO CAPACITY – DO NOT EXCEED
300 LB. OR VEHICLE FRONT GROSS
AXLE WEIGHT RATING. (GAWR)**

9000	LB. MAX. WINCH LINE PULL
------	--------------------------

Receiver Shown In Proper Position

Hitch Requires 5/8” Pin and Clip

Equipment Required:

Fastener Kit: K65017

Wrenches: 10mm, 15mm,
17mm, 3/4”

Drill Bits: None

- * 93-97 Ford Ranger With Fog Light Option (Round Light)
- * Mazda B Series Truck & Navajo (Rectangular Light)

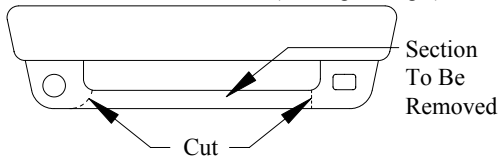

FIGURE 1

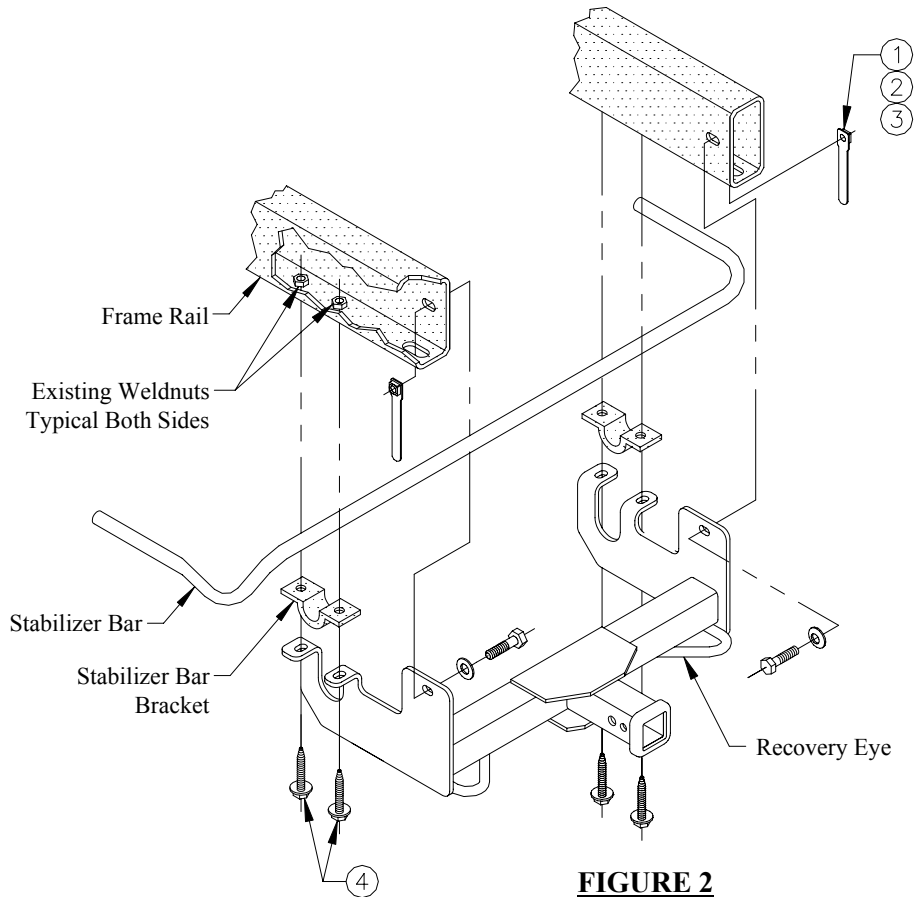

FIGURE 2

①	Qty. (2)	Hex Bolt, 1/2”-13 x 1-3/4”	③	Qty. (2)	Handle Nut, 1/2”
②	Qty. (2)	Conical Washer, 1/2”	④	Qty. (4)	Hex Bolt, M10 x 1.50 x 45

****NOTE: All Mazda vehicles and ‘93 through -97 Ford Rangers with fog light option require extensive fascia cut. See Figure 1. CONSULT VEHICLE OWNER.**

1. Remove front air dam (if present).
2. Remove stabilizer bar fasteners.
3. Raise receiver into position, sandwiching stabilizer bar bracket between receiver and frame rail, and install all fasteners as shown in Figure 2.
4. If desired, trim and reinstall the front air dam. **CONSULT VEHICLE OWNER BEFORE TRIMMING.**

Tighten all M10 fasteners with torque wrench to 42 Lb.-Ft (57 N-m).

Tighten all 1/2” fasteners with torque wrench to 50 Lb.-Ft (68N-m).