

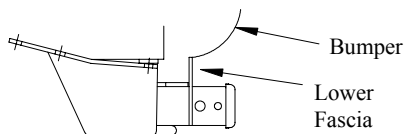

Front Mounted Receiver Installation Instructions Jeep Cherokee, Comanche, Wagoneer (Downsize)



Receiver Shown In Proper Position

**CARGO CAPACITY – DO NOT EXCEED
300 LB. OR VEHICLE FRONT GROSS
AXLE WEIGHT RATING. (GAWR)**

9000	LB. MAX. WINCH LINE PULL
------	--------------------------

Equipment Required:

Fastener Kit: K65009

Wrenches: 15mm, 7/8"

Drill Bits: 1/2"

Hammer

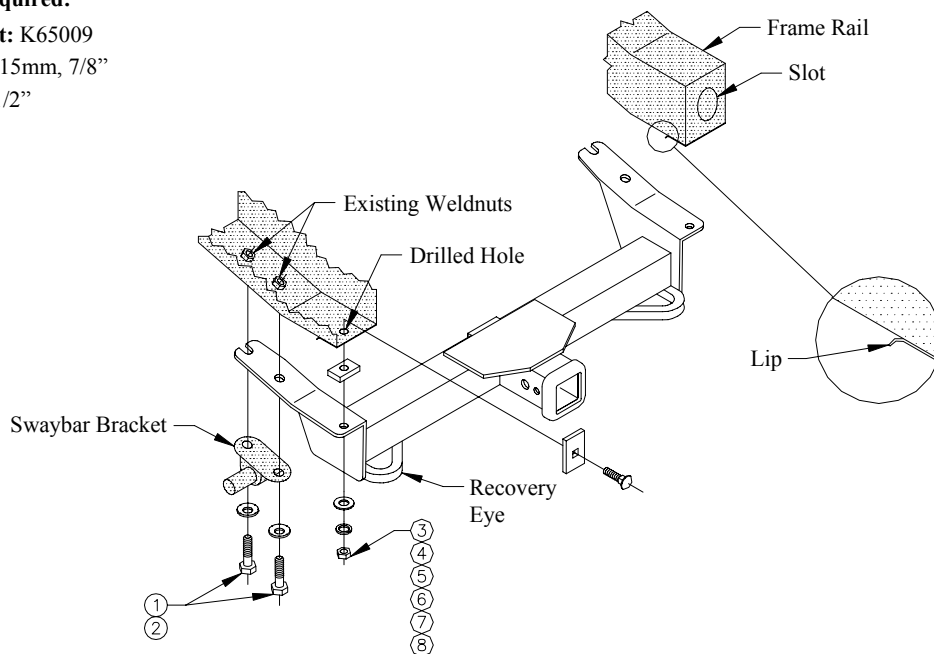

①	Qty. (4)	Hex Bolt, M10 x 1.50 x 35	⑥	Qty. (2)	Flat Washer, 1/2"
②	Qty. (4)	Conical Washer, 3/8"	⑦	Qty. (2)	Lock Washer, 1/2"
③	Qty. (2)	Carriage Bolt, 1/2"-13 x 2-1/4"	⑧	Qty. (2)	Hex Nut, 1/2"
④	Qty. (2)	Spacer, 1-1/2" x 2" x 1/4"	⑨	Qty. (2)	Pull Wire
⑤	Qty. (2)	Spacer, 1" x 2" x 7/16"			

1. If present, remove steel skid shield and return to vehicle owner.
2. Remove lower fascia or trim to clear receiver. **CONSULT VEHICLE OWNER BEFORE TRIMMING.**
3. Lower swaybar bracket on each frame rail.
4. Raise hitch into position and loosely reinstall swaybar bracket as shown above. **NOTE:** The lip on the underside of the frame rail may need to be flattened so block can be installed.
5. Using the receiver as a template drill a 1/2" hole as shown above.
6. Feed the remaining fasteners as shown above through slot in the end of the frame rails using pull wire.

Tighten all M10 CL10.9 fasteners with torque wrench to 42 Lb.-Ft (57 N-m).

Tighten all 1/2" GR5 fasteners with torque wrench to 75 Lb.-Ft (102 N-m).