

Front Mounted Receiver Installation Instructions Dodge Ram*

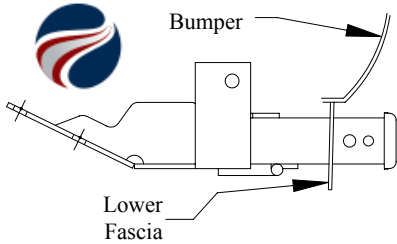

Receiver Shown In Proper Position

**CARGO CAPACITY – DO NOT EXCEED
500 LB. OR VEHICLE FRONT GROSS
AXLE WEIGHT RATING. (GAWR)**

9000	LB. MAX. WINCH LINE PULL
------	--------------------------

Equipment Required:

Fastener Kit: 01131-016

Wrenches: 15mm, 16mm, 18mm,
T-30 Torx® Driver

Drill Bits: None

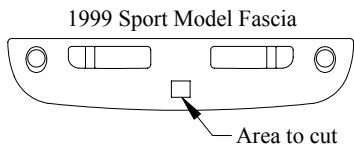

Figure 1

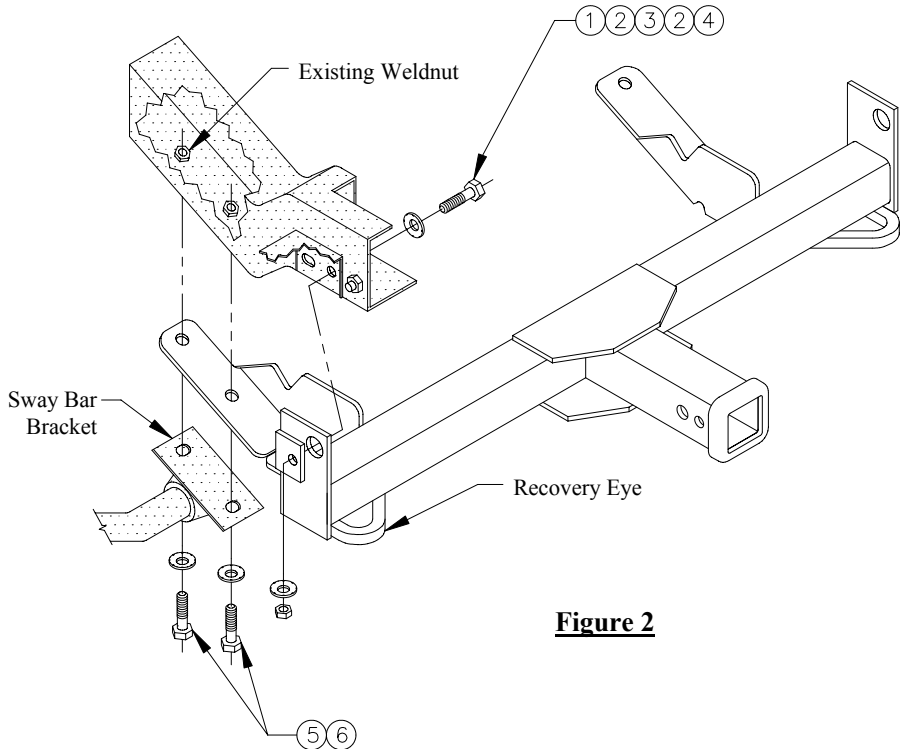

Figure 2

①	Qty. (2)	Hex Bolt, M12 x 1.75 x 45 CL10.9	④	Qty. (2)	Nut, M12 x 1.75
②	Qty. (4)	Conical Washer, 1/2"	⑤	Qty. (4)	Hex Bolt, M10 x 1.5 x 35 CL10.9
③	Qty. (2)	Spacer, 2" x 1-1/2" x 1/4"	⑥	Qty. (4)	Conical Washer, 3/8"

* **NOTE:** 1999 "Sport Model" vehicles require extensive fascia cut. See Figure 1.
CONSULT VEHICLE OWNER BEFORE TRIMMING.

1. If present, remove lower fascia.
 2. Lower sway bar brackets and return fasteners to vehicle owner.
 3. If present, remove any fastener in the forward attachment hole on vehicle.
 4. Raise receiver into position and reattach sway bar brackets placing the receiver between the frame and the sway bar bracket as shown in Figure 2.
 5. Attach forward fasteners as shown in Figure 2.
- NOTE:** Bumper brackets may require repositioning to align with receiver mounting holes.
6. If desired, trim lower fascia and reinstall. **CONSULT VEHICLE OWNER BEFORE TRIMMING.**

Tighten all M10 CL10.9 fasteners with torque wrench to 35 Lb.-Ft (47 N-m).
Tighten all M12 CL10.9 fasteners with torque wrench to 75 Lb.-Ft (102 N-m).