

Installation Instructions

Part Number:
41990

WARNING!

Failure to follow all warnings and instructions may result in product failure, property damage, serious bodily injury, and/or death.

NOTE!

Installer must follow and understand all instructions and warnings for any product(s) to which this product is used in conjunction with or installed.

Service Body Hitch – Long Tube
Requires Bracket kit 4907 or 4916
not included with this product to complete installation.

Do Not Exceed Lower of Towing Vehicle Manufacturer’s Rating or Max Gross Trailer WT / Max Tongue WT ratings below

Hitch type	Max Gross Trailer WT	Max Tongue WT
Weight Carrying Ball Mount	16,000lb. (7264 Kg)	1600lb. (726 Kg)

WARNING! THIS PRODUCT IS NOT TO BE USED WITH A WEIGHT-DISTRIBUTING HITCH SYSTEM.

Use in weight-carrying mode only.

The above weight ratings only apply to this product properly installed in strict accordance to these instructions by trained personnel. It is the responsibility of the installer to assure that all of these and following or subsequent instructions, requirements and warnings are properly met.

NOTE!

Read, understand, follow and save these instructions. Install and use this product only as specified in these instructions. Never allow installation or use of this product by anyone without providing them with these instructions.

This product is authorized for use with appropriate Bulldog, Draw-Tite, Hidden Hitch, Highland, Reese, Rola, & Tow-Ready brand accessories.

Note! The installation of this hitch product must be performed only by experienced and trained mechanics, technicians, welders etc. This product is not intended to be installed by an average consumer not familiar with or experienced in installing towing components on commercial vehicles. Attaching this hitch product to tow vehicle frame may void vehicle manufacturer(s) warranty. Check with vehicle manufacturer(s) before installing this product.

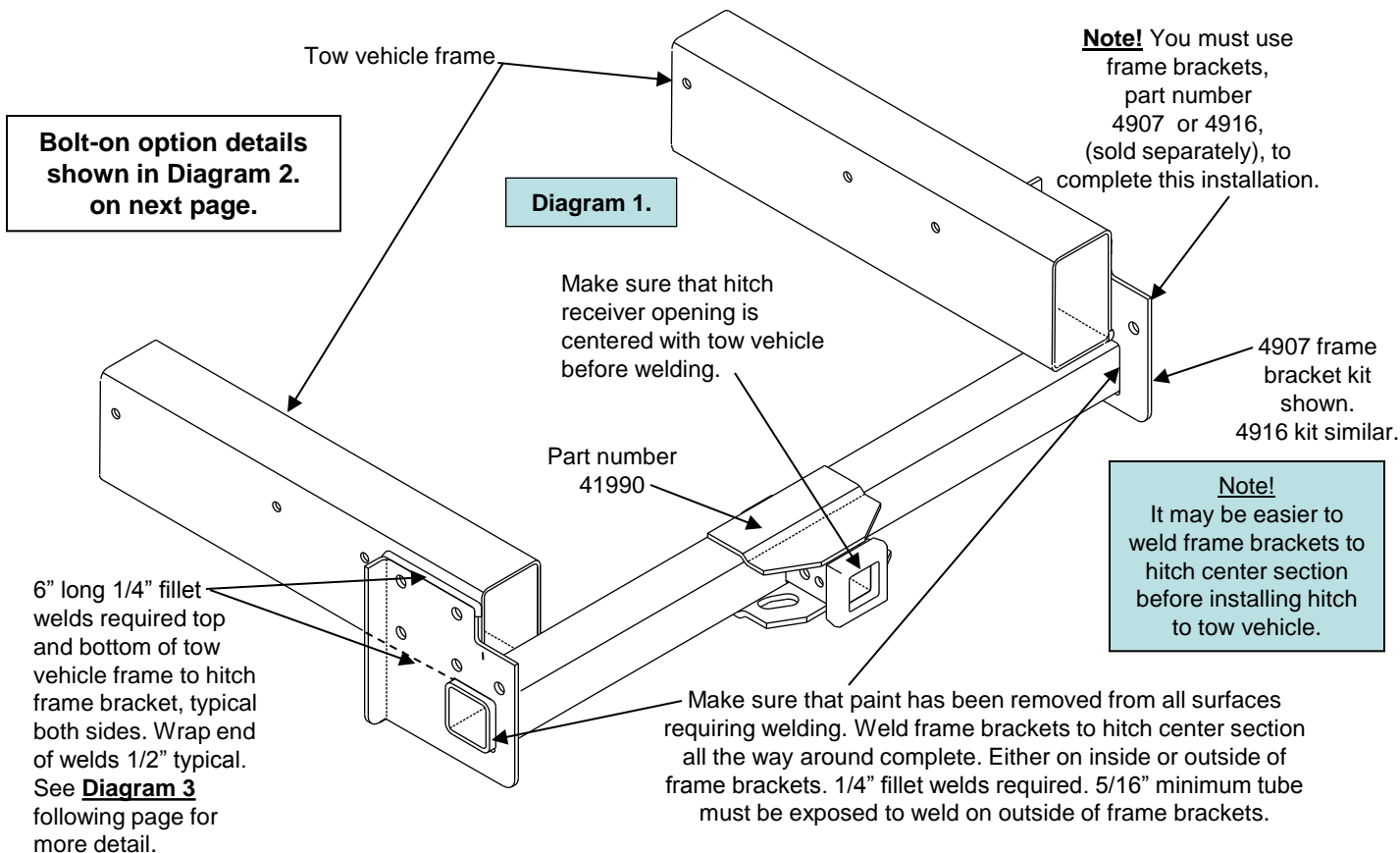

Note: check hitch frequently for damage, making sure hitch ball is properly tightened. A hitch or ball which has been damaged should be removed and replaced. Observe safety precautions when working beneath a vehicle and wear eye protection. Do not cut access or attachment holes with a torch.

Installation Instructions

Part Number:

Service Body Hitch – Long Tube

41990

Requires Bracket kit 4907 or 4916

not included with this product to complete installation.

1. Examine tow vehicle to determine adequate mounting surface to assure that attachments meet requirements of these instructions and warnings. Make sure that no fuel lines, electrical wires, brake lines etc will be smashed, crimped, or damaged in any way by the installation of this hitch product. No cutting, relocation or removal of tow vehicle components can be performed without the approval of tow vehicle manufacturer(s) if required for installation of this product.
2. **Weld-On Option** After determining location of frame brackets relative to center hitch section surfaces must be prepared for welding. Paint and other surface treatments must be removed to allow adequate weld penetration and strength. Be careful to grind paint off of hitch components. Also remove paint and or plating, undercoating, rust, oil etc from vehicle frame. Use a flexible disc grinding wheel to remove paint etc. Using a rigid disc could cause gouging and notching of metal which could cause high stress points and weaken hitch and or frame. All welds must be performed by a A.W.S. certified welder for the type and position of welds being done. **(Refer to [Diagram 3](#), below for minimum weld requirements.)**
3. **Bolt-On Option** Determine location of frame brackets to assure that at minimum (4) 5/8" diameter bolts per side can be installed, and that you have proper clearance for hitch and hitch accessories. Before drilling holes in vehicle frame remove any rust or undercoating to assure that holes can be drilled accurately. It may be easier to clamp frame brackets in place and use the holes in the brackets as guides to drill the frame. Make sure that there are no electrical wires, brake lines, fuel lines and other obstructions inside of frame before drilling. Follow instructions in **[Diagram 2](#), below regarding maximum hole sizes, minimum bolt sizes and strengths and the use of proper locking type nuts.** Make sure to tighten bolts to proper torque using a torque wrench.

This Diagram below shows required minimum requirements for a bolt-on installation. It is the responsibility of the hitch installer to determine the acceptability of the tow vehicle structure for the hitch tow rating.

NOTES:

1. Note all precautions in steps above.
2. Do not drill holes in frame more than 1/32" larger than bolt.
3. Use 5/8" diameter bolts minimum, Grade 5 or stronger only.
4. Use locking type nuts with all bolts.
5. Must use at least (4) 5/8" diameter minimum bolts per side.

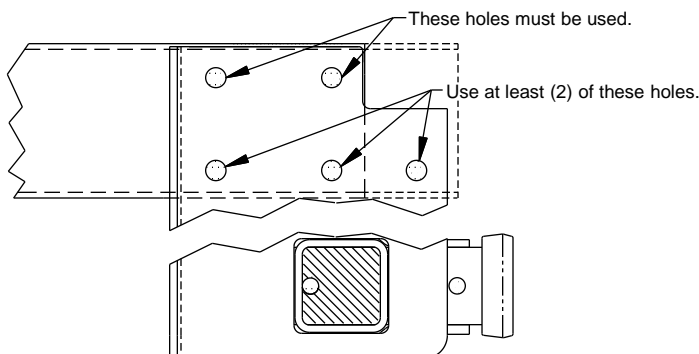

Side view of hitch and tow vehicle frame showing bolt-on installation.

Diagram 2.

This Diagram below shows required minimum weld lengths and fillet sizes for installation. It is the responsibility of the hitch installer to determine the acceptability of the tow vehicle structure for the hitch tow rating.

NOTES:

1. Remove all paint before welding.
2. All welds 1/4".
3. Do not weld near or across holes in hitch.
4. All welds must be done in accordance with A.W.S. specifications.
5. After welding repaint bare metal surfaces.

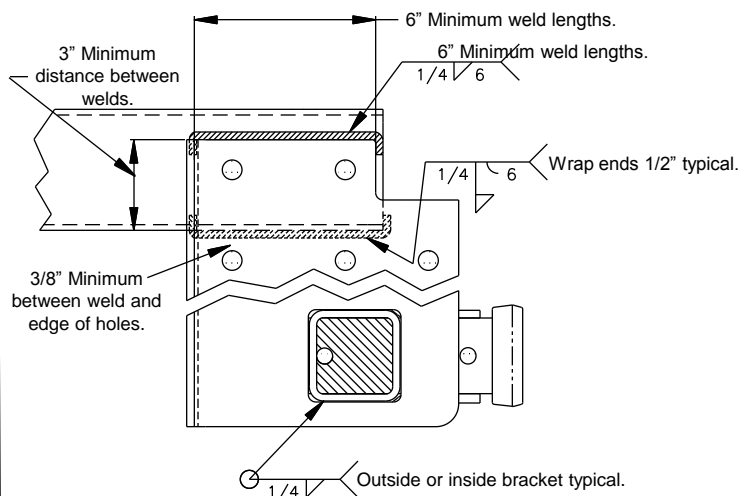

Side view of hitch and tow vehicle frame showing weld-on installation.

Diagram 3.