

INSTALLATION INSTRUCTIONS MULTI-FIT

Product No.

Cequent



41947

SMALL PARTS
PACKAGE 41947F

WARNING: DO NOT LUBRICATE THREADS, BOLT FAILURE MAY OCCUR DUE TO OVER TIGHTENING.
WARNING: DO NOT DRILL OR WELD TO THIS HITCH.

IMPORTANT NOTES
USE ONLY MANUFACTURER'S SUPPLIED OR APPROVED BOLTS, LOCKNUTS, AND WASHERS TO INSTALL THIS HITCH

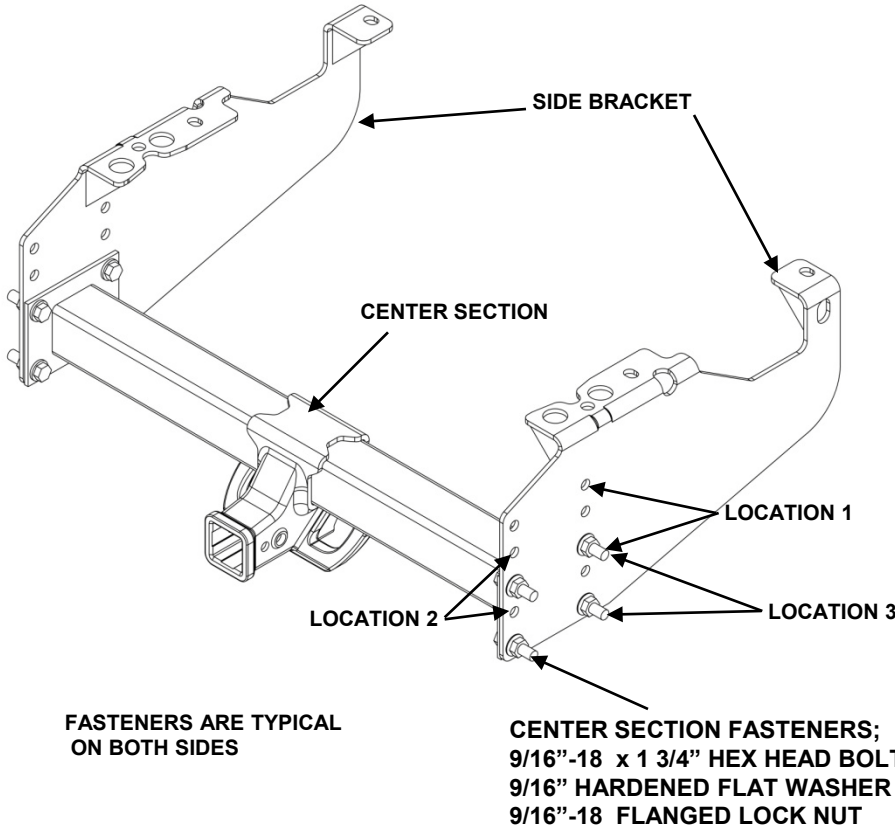

TOOLS REQUIRED

13/16" , 7/8" SOCKET & WRENCH
21mm, 24mm SOCKET & WRENCH
11/16" DRILL BIT
TORQUE WRENCH
SAFETY GLASSES

**3 HEIGHT LOCATIONS
FOR CENTER SECTION
(shown in location 3 – lowest)**

Height from bottom of frame
to top of receiver tube
Location 1 = 6-5/8"
Location 2 = 8-1/4"
Location 3 = 10-1/4"

CENTER SECTION ASSEMBLY

GENERAL INSTRUCTIONS:

1. Remove center section and side brackets from box. Refer to specific instructions for proper position of side brackets.
2. Loosely install side brackets.
3. Install center section
4. Tighten center section fasteners , then frame attachment fasteners

FOR ALL INSTALLATIONS: UNLESS OTHER WISE NOTED

1. Torque all 9/16" grade 5 nuts & bolts to 120 lb.ft. (163 N*M)
2. Torque all 16mm CL10.9 hardware to 210 lb.ft. (285 N*M)





Note; Paint any bare metal to prevent rust.

Do Not Exceed Lower of Towing Vehicle Manufacturer's Rating or

Hitch type	Max Gross Trailer WT (LB)	Max Tongue WT (LB)
Weight Distributing	16,000 (7264 kg)	1,600 (726 kg)
Weight Carrying Ball Mount	15,000 (6810 kg)	1,600 (726 kg)

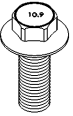
FASTENER KITS CONTAIN THE BELOW ITEMS
La trousse de visserie contient les éléments ci-dessous
El kit de tornillos contiene los siguientes artículos

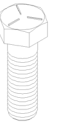
41947N Fastener Kit, Trousse de visserie 41947N, Kit de tornillos 41947N:

(METRIC) 	Qty. Qté. Ctd. (6)	-HEX HEAD BOLT M16X2.00 X 45mm - CL10.9 - BOULON HEXAGONAL M16 X 2.00 X 45mm- CL 10.9 - PERNO HEXAGONAL M16 X 2.00 X 45mm – CL10.9		Qty. Qté. Ctd. (6)	- LOCKNUT FLANGED M16X2.0 CL10 - ÉCROU COLLERETTE M16X2.0 CL10 - BRIDA TUERCA M16x2.0 CL10
	Qty. Qté. Ctd. (8)	- HEX HEAD BOLT 9/16-18 X 1.75" – GR5 - BOULON HEXAGONAL 9/16 x 1-3/4 po - GR5 - PERNO HEXAGONAL 9/16" x 1 3/4 – GR5		Qty. Qté. Ctd. (8)	- FLANGED LOCK NUT 9/16 – 18 - CONTRE-ÉCROU À EMBASE 9/16 po - TUERCAS CON ARANDELA 9/16"
	Qty. Qté. Ctd. (8)	- FLAT WASHER 9/16" HARDENED - RONDELLE PLATE TREMPÉE 9/16 po - ARANDELA PLANA 9/16			

DODGE 3500/4500/5500 **STERLING 4500/5500** **CAB AND CHASSIS ONLY**

TOOLS REQUIRED

13/16", 7/8" SOCKET
21mm, 24mm SOCKET
11/16" DRILL BIT
TORQUE WRENCH
SAFETY GLASSES

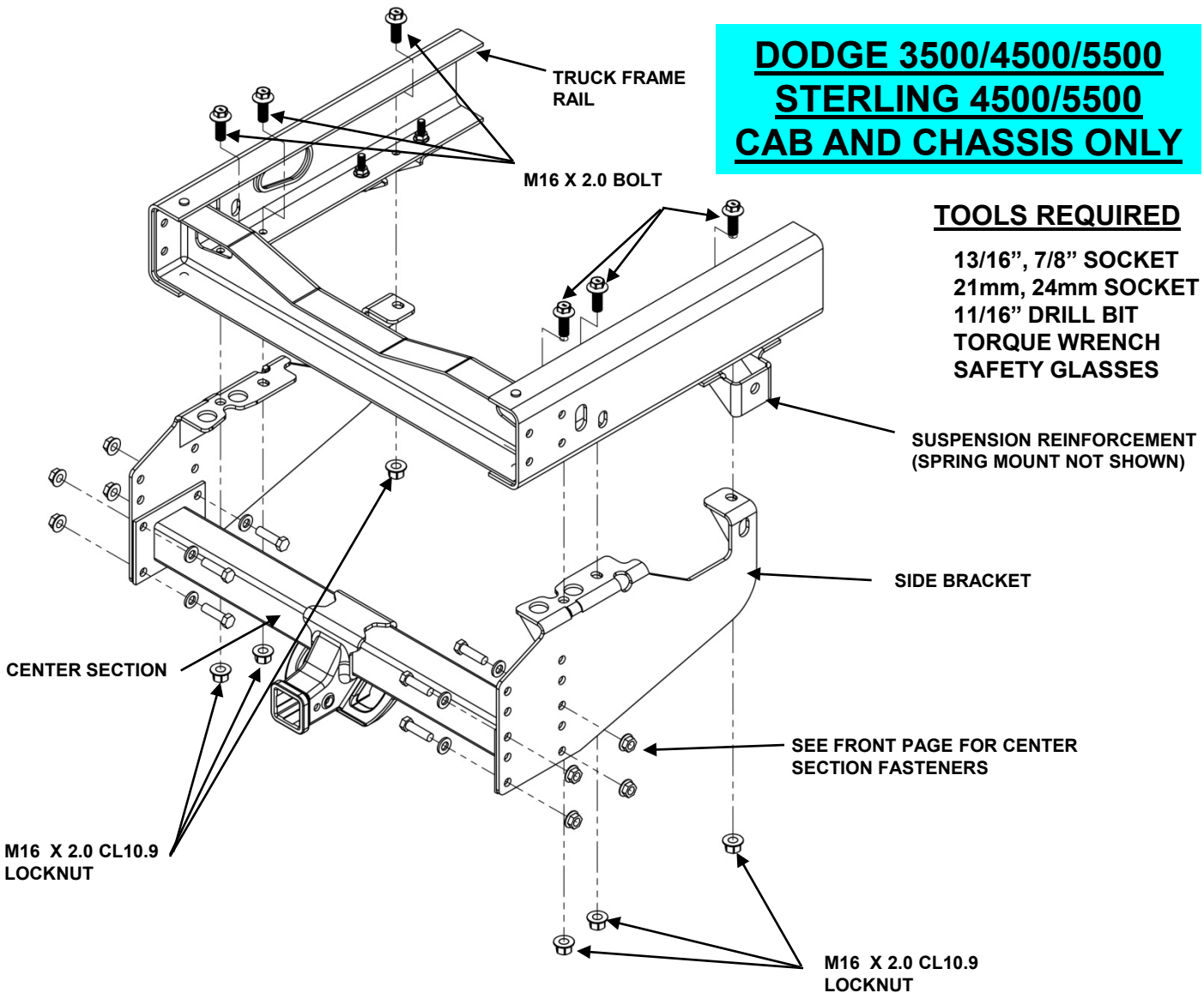

NOTE:

General assembly - loosely install side brackets on vehicle (this page); install center section assembly and tighten all fasteners to proper specifications (page 1)

07-12 DODGE / STERLING 3500, 4500, 5500 CAB AND CHASSIS ONLY (34" FRAME)

1. Fuel tank location varies per vehicle. Center fuel tank between frame rails
2. Raise and clamp hitch side brackets into position, by centering forward attachment between suspension reinforcement and flush with outside of frame rail.
3. Using the side bracket as a template, mark the frame at the center of each attachment hole.
Warning; Do not drill into fuel or electrical lines, take appropriate precaution before step 4.
4. Remove the side bracket and drill 9/16" holes in frame. Hint; a small pilot hole is recommended.
5. Install side bracket loosely with the fasteners shown above.
6. Raise center section of hitch for vehicle requirements. Install center section with (8) 9/16" x 1-3/4" bolts, washers, and flanged locknuts.
7. Tighten hitch side brackets to center section. Tighten hitch side brackets to truck frame.

FORD F-350, F-450, F-550 CAB AND CHASSIS ONLY

TOOLS REQUIRED

13/16", 7/8" SOCKET
21mm, 24mm SOCKET
11/16" DRILL BIT
TORQUE WRENCH
SAFETY GLASSES

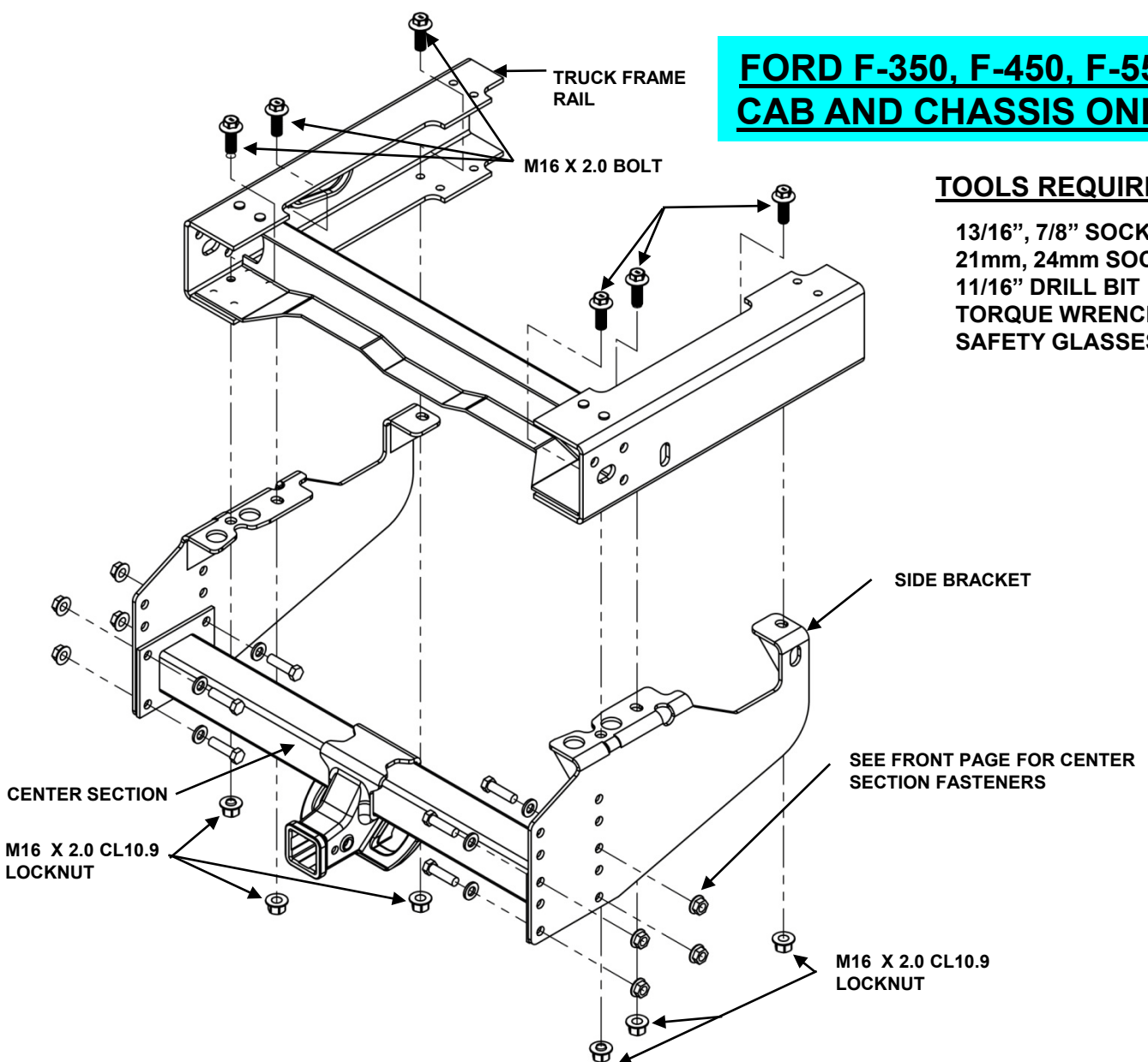

NOTE:

General assembly - loosely install side brackets on vehicle (this page); install center section assembly and tighten all fasteners to proper specifications (page 1)

99-12 FORD F-350, F-450, F-550 CAB AND CHASSIS ONLY (34" FRAME)

1. Raise and clamp hitch side brackets into position, by centering on forward attachment hole between suspension reinforcement and around frame rivets at rear crossmember.
2. Using the side bracket as a template, mark the frame at the center of each remaining attachment hole.
Warning; Do not drill into fuel or electrical lines, take appropriate precaution before step 3.
3. Remove the side bracket and drill 9/16" holes in frame. Hint; a small pilot hole is recommended.
4. Install side bracket loosely with the fasteners shown above.
5. Raise center section of hitch for vehicle requirements. Install center section with (8) 9/16" x 1-3/4" bolts, washers, and flanged locknuts.
6. Tighten hitch side brackets to center section. Tighten hitch side brackets to truck frame.

GMC / CHEVY 3500 CAB AND CHASSIS ONLY

TOOLS REQUIRED

9/16", 3/4" SOCKET
21mm, 24mm SOCKET
11/16" DRILL BIT
TORQUE WRENCH
SAFETY GLASSES

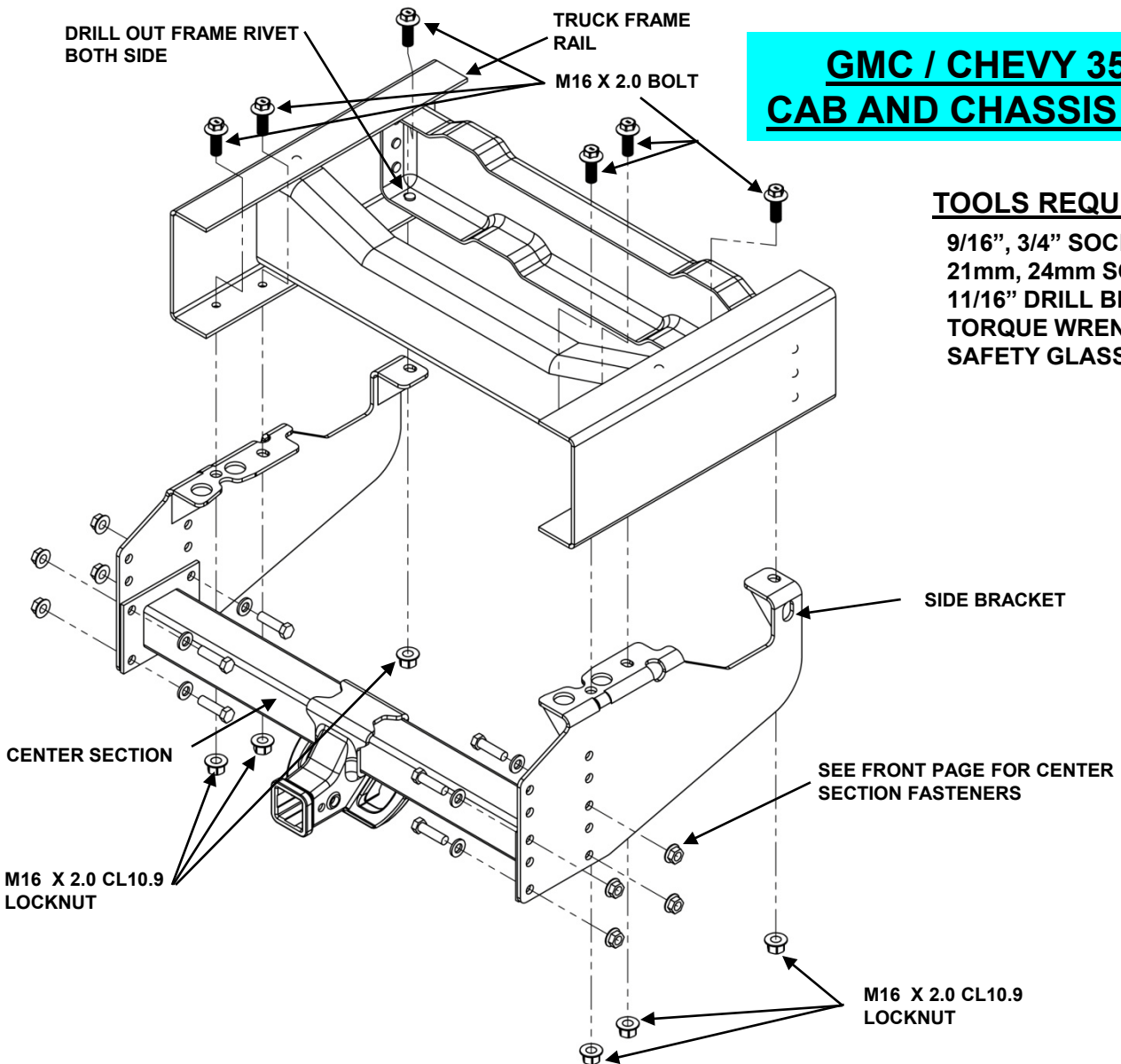

NOTE:

General assembly - loosely install side brackets on vehicle (this page); install center section assembly and tighten all fasteners to proper specifications (page 1)

85-13 GMC / CHEVY 3500 CAB AND CHASSIS ONLY (34" FRAME)

1. Raise and clamp hitch side brackets into position, by centering the forward attachment hole over frame rivet and flush with outside of frame.
2. Using the side bracket as a template, mark the frame at the center of each remaining attachment hole and rivet.

Warning; Do not drill into fuel or electrical lines, take appropriate precaution before step 3.

3. Remove the side bracket and drill 9/16" holes in frame and frame rivet. Rivet will be removed and its hole is used to attach hitch. Hint; a small pilot hole is recommended.
4. Install side bracket loosely with the fasteners shown above.
5. Raise center section of hitch for vehicle requirements. Install center section with (8) 9/16" x 1-3/4" bolts, washers, and flanged locknuts.
6. Tighten hitch side brackets to center section. Tighten hitch side brackets to truck frame.

**GMC / CHEVY 4500,
5500, 6500, 7500, 8500
CAB AND CHASSIS ONLY**

TOOLS REQUIRED

1/4" & 9/16" DRILL BIT
9/16", 3/4" SOCKET, WRENCH
21mm, 24mm SOCKET, WRENCH
11/16" DRILL BIT
TORQUE WRENCH

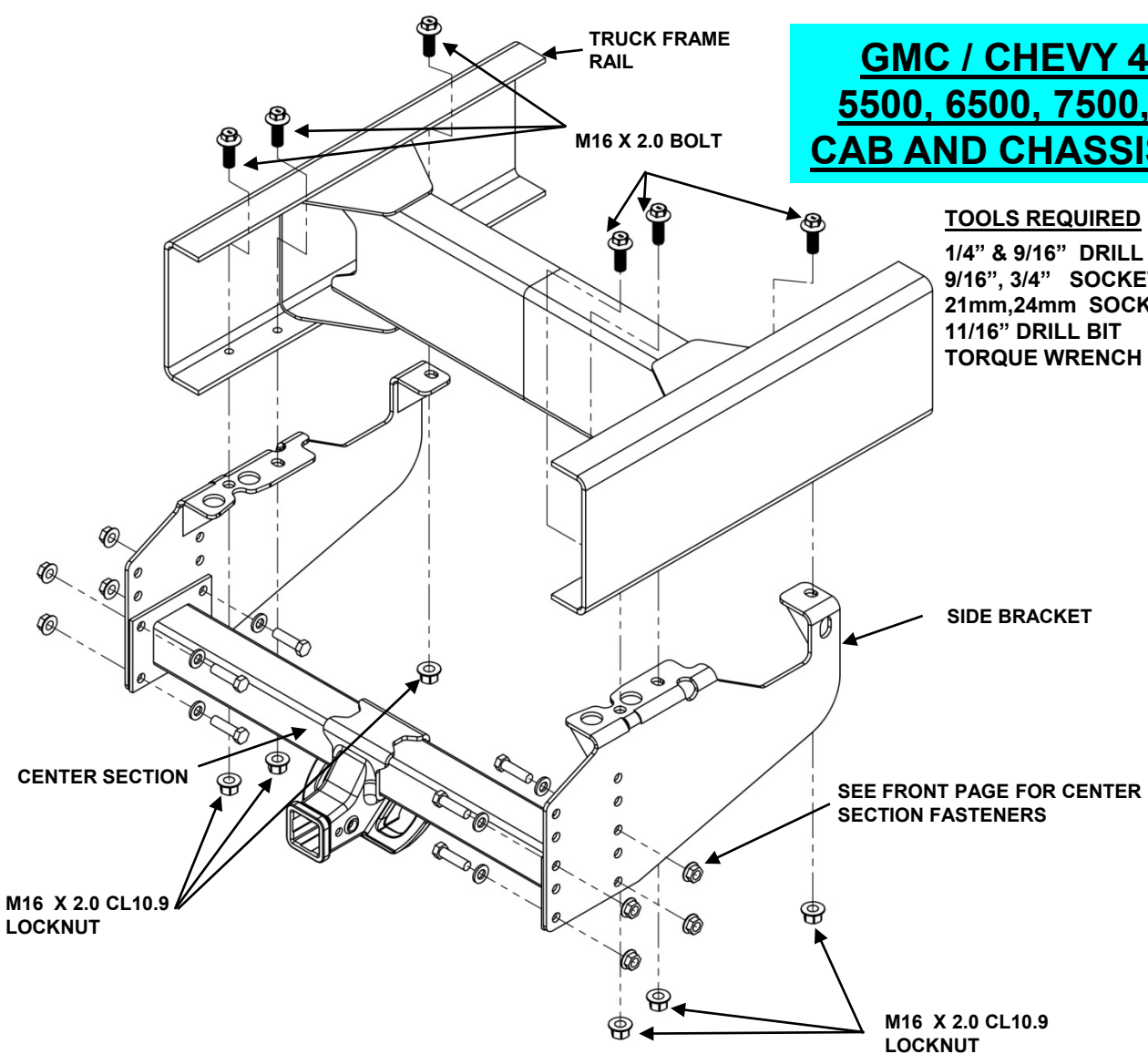

NOTE:
General assembly - loosely install side brackets on vehicle (this page); install center section assembly and tighten all fasteners to proper specifications (page 1)

**99-10 GMC / CHEVY 4500, 5500, 6500, 7500, 8500 (TOPKICK / KODIAK)
CAB AND CHASSIS ONLY (34" FRAME)**

1. Raise and clamp hitch side brackets into position, flush with outside of frame and located so drilled attachment hole do not interfere with frame cross members and allow flat bolting surface.
2. Using the side bracket as a template, mark the frame at the center of each attachment hole.
Warning; Do not drill into fuel or electrical lines, take appropriate precaution before step 3.
3. Remove the side bracket and drill 9/16" holes in frame. Hint; a small pilot hole is recommended.
4. Install side bracket loosely with the fasteners shown above.
5. Raise center section of hitch for vehicle requirements. Install center section with (8) 9/16" x 1-3/4" bolts, washers, and flanged locknuts.
6. Tighten hitch side brackets to center section. Tighten hitch side brackets to truck frame.

GMC / CHEVY PICKUP **8 FT BED ONLY**

TOOLS REQUIRED

9/16", 3/4" SOCKET
21mm, 24mm SOCKET
11/16" DRILL BIT
TORQUE WRENCH
SAFETY GLASSES

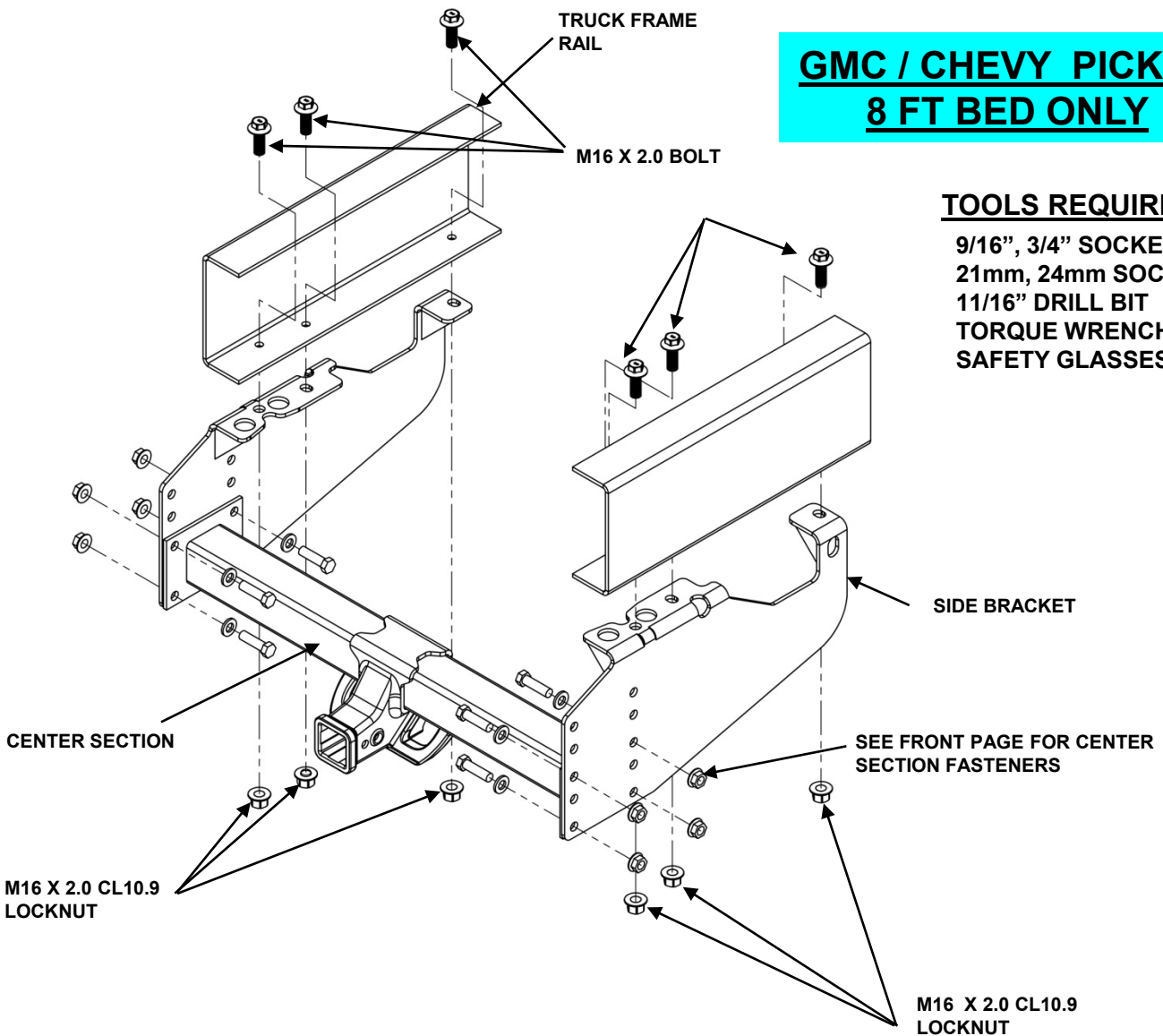

NOTE:

General assembly - loosely install side brackets on vehicle (this page); install center section assembly and tighten all fasteners to proper specifications (page 1)

63-87 GMC / CHEVY PICKUP 8 FT BED ONLY; **88-91 GMC / CHEVY CREW CAB PICKUP 8 FT BED ONLY**

1. Raise and clamp hitch side brackets into position, by aligning side bracket to miss frame and suspension components. Measurement from outside of side bracket to outside of other side bracket will be 34".
2. Using the side bracket as a template, mark the frame at the center of each attachment hole.
Warning; Do not drill into fuel or electrical lines, take appropriate precaution before step 3.
3. Remove the side bracket and drill 9/16" holes in frame. Hint; a small pilot hole is recommended.
4. Install side bracket loosely with the fasteners shown above.
5. Raise center section of hitch for vehicle requirements. Install center section with (8) 9/16" x 1-3/4" bolts, washers, and flanged locknuts.
6. Tighten hitch side brackets to center section. Tighten hitch side brackets to truck frame.