



Installation Instructions

Ford Econoline Van

Part Numbers:

41945

All Models

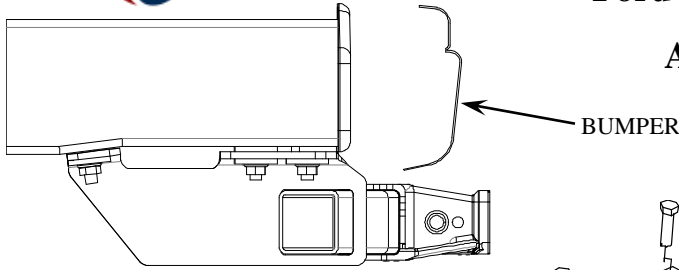

BUMPER

Hitch Shown In Proper Position

Equipment Required:

Fastener Kit: 41945F

Wrenches: 13/16", 7/8"

Drill Bits: NONE

**Do Not Exceed Lower of Towing Vehicle
Manufacturer's Rating or**

Hitch type	Max Gross Trailer WT (LB)	Max Tongue WT (LB)
Weight Distributing	12000 (5448 Kg)	1200 (545 Kg)
Weight Carrying Ball Mount	10000 (4540 Kg)	1500 (681 Kg)

Wiring Access Location: SUV1, SUV2

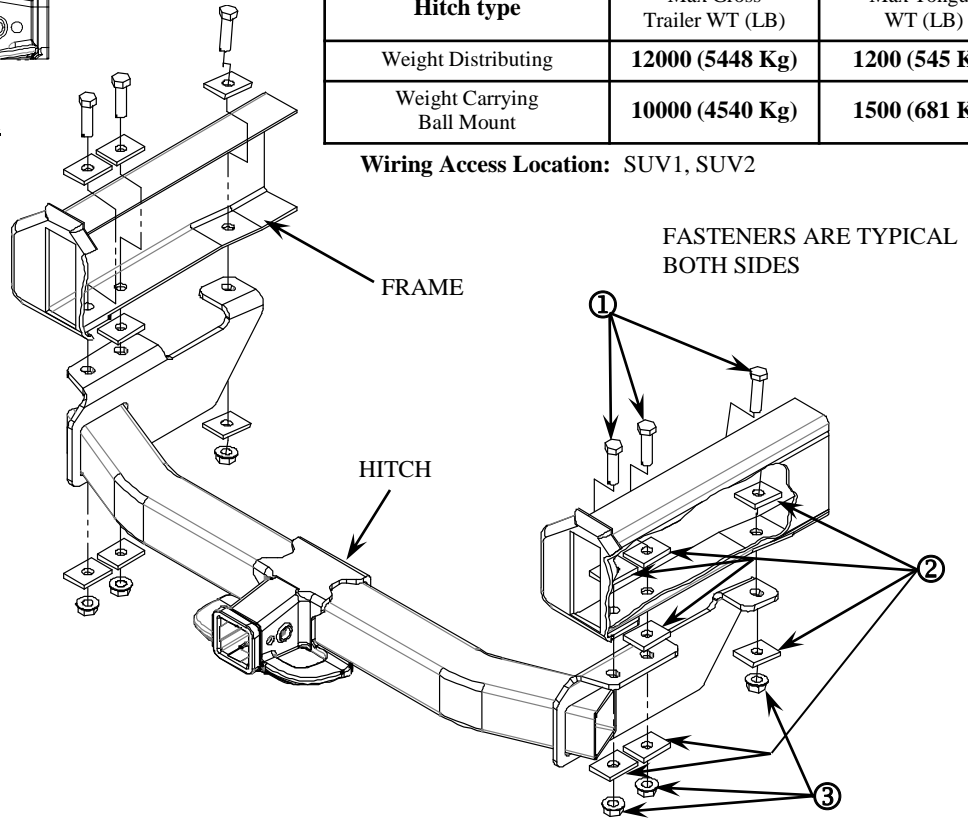

①	Qty. (6)	BOLT- HEX HEAD 9/16-18 X 2.00 GR5	③	Qty. (6)	LOCKNUT – FLANGED 9/16-18
②	Qty. (14)	BLOCK – 1.50 X 2.00 X .250			

- IF PRESENT, LOWER CARBON CANISTER FROM DRIVER'S SIDE FRAME RAIL.
- DISCONNECT FROM BUMPER, FACTORY INSTALLED OPTIONAL DRIVER'S SIDE TRAILER WIRING CONNECTOR.
- RAISE HITCH INTO POSITION AND ATTACH WITH FASTENERS AS SHOWN ABOVE.
MAKE SURE TO SANDWICH A BLOCK BETWEEN HITCH AND FRAME AT MIDDLE ATTACHMENT.
- REINSTALL FACTORY TRAILER WIRING CONNECTOR TO CLEAR HITCH
- REATTACH CARBON CANISTER IF PRESENT – CARBON CANISTER MUST NOT CONTACT BOLT HEAD, IF IT DOES, LOOSEN CANISTER FASTENERS AND REPOSITION TO ENSURE CLEARANCE WITH BOLT HEAD.

Tighten all 9/16-18 grade 5 fasteners with torque wrench to 120 Lb.-Ft. (163 n*m)