

Cequent



Installation Instructions

CHEVROLET SILVERADO PICKUP GMC SIERRA PICKUP

Part Numbers:

41932

81587

VEHICLES W/ AMBER TURN SIGNALS AND FACTORY BUMPER

NOTE!-FACTORY INSTALLED STEEL STEP BUMPER AND BRACKETS MUST BE USED IN CONJUNCTION WITH HITCH.

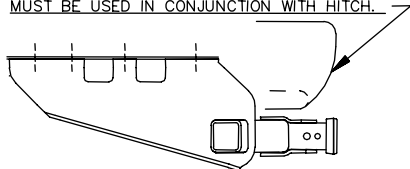

Hitch Shown In Proper Position

Equipment Required:

Fastener Kit: 41932N

Wrenches: 7/8", 21mm

Drill Bits: NONE

NOTE!-FACTORY INSTALLED STEEL STEP BUMPER AND BRACKETS MUST BE USED IN CONJUNCTION WITH HITCH.

NOTE: ALL FASTENERS TYPICAL BOTH SIDES OF VEHICLE

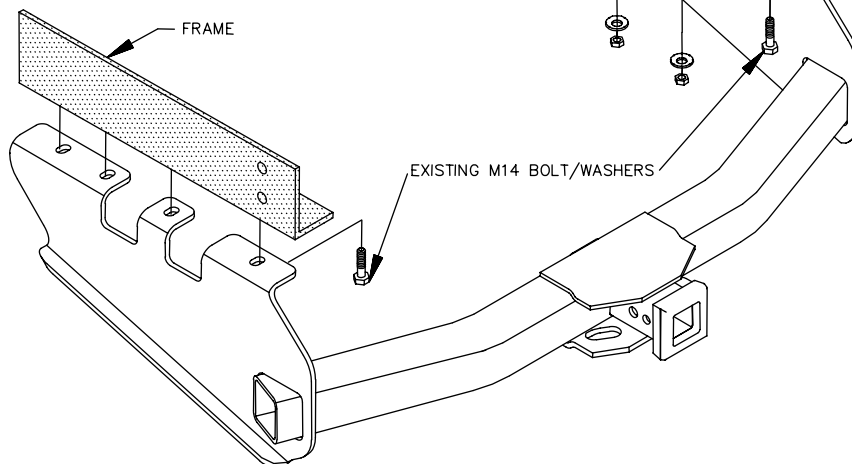

**Do Not Exceed Lower of Towing Vehicle
Manufacturer's Rating or**

Hitch type	Max Gross Trailer WT (LB)	Max Tongue WT (LB)
Weight Distributing	14,000 (6356 Kg)	1400 (636 Kg)
Weight Carrying Ball Mount	12,000 (5448 Kg)	1200 (545 Kg)

Wiring Access Location: PU3

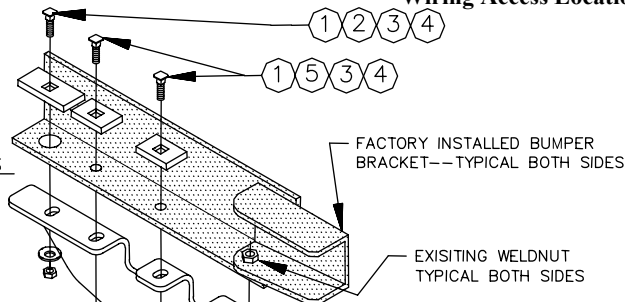

①	Qty. (6)	1/2"-13 X 1-3/4" GR 5 CARRIAGE BOLT	④	Qty. (6)	HEX NUT
②	Qty. (2)	1/4" X 1-1/2" X 3" BLOCK	⑤	Qty. (4)	1/4" X 1-1/2" X 2" BLOCK
③	Qty. (6)	CONICAL TOOTHED WASHER			

1. Remove existing M14 bolts from end of each frame rail.
2. Lift receiver into position, locating rearmost slots in receiver under existing weldnuts in vehicle frame.
3. Reinstall existing M14 bolts through receiver and frame into existing weldnuts.
4. Install remaining fasteners as shown.

Tighten all M14 fasteners with torque wrench to 115 Lb-Ft. (156 N*M)

Tighten all 1/2" GR 5 fasteners with torque wrench to 75 Lb.-Ft. (156 N*M)