

Installation Instructions

Part Numbers:

36524
90219
06147

Ford Escape

Drawbar Kit:
36071

**Do Not Exceed Lower of Towing Vehicle
Manufacturer's Rating or**

3500 LB (1589 Kg) Max Gross Trailer Weight
300 LB (136 Kg) Max Tongue Weight

Accessory Rating

B

Wiring Access Location: SUV 1 & 2

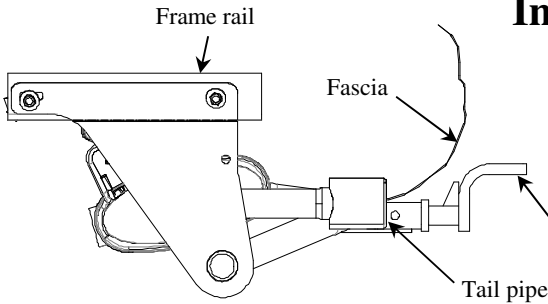

Drawbar must be used in the **Rise** position only.

Hitch Shown In Proper Position

Equipment Required:

Fastener Kit: 36524F

Wrenches: 11/16"

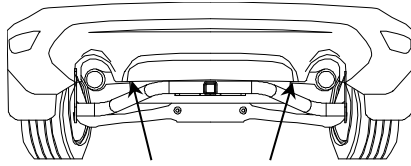

Lift gate sensor reduced to this area on vehicles with the "Hand free lift gate" option.

Figure 2

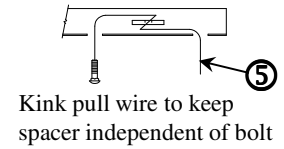
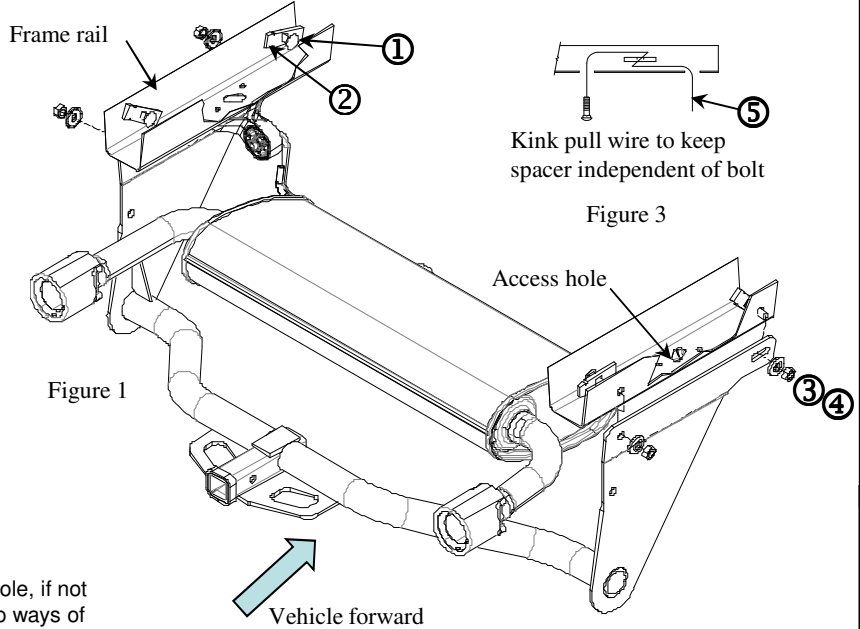
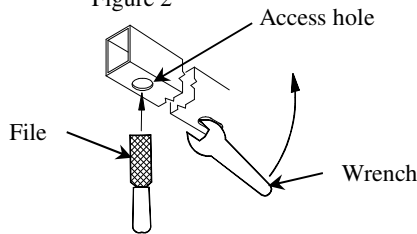

Figure 3

INSTRUCTIONS:

1. Check to see if spacer and bolt head will fit through access hole, if not modify hole to accept hardware, the illustration above shows two ways of achieving this, the first is using a file, the second is by inserting a wrench or prying as shown. **Enlarge hole just enough to get hardware through.**

Note: Fasteners typical both sides

①	Qty. (4)	Carriage bolt 7/16-14 X 1.50 GR5	④	Qty. (4)	Hex nut 7/16-14 GR2
②	Qty. (4)	Spacer 1/4 X 7/8 X 3.00	⑤	Qty. (4)	Pull wire 7/16
③	Qty. (4)	Conical washer 7/16			

Note: With the hitch installed on vehicle with "Hands free lift gate" options it will only work in limited area. See Figure 2.

1. Feed spacers and carriage bolts into position using the pull wires provided (both rail). Leave pull wire attached. Note: It is much easier if bolt and spacer are not engaged while inserting them into frame, refer to illustration. See Figure 3.
2. Push (only) fasteners back into frame rail leaving pull wire and the extra wire sticking out of the frame rail.
3. Raise hitch into position between frame rails, feed pull wires thru adjacent holes in the hitch. On the passenger side raise the forward end of the bracket over the hoses crossing the frame rail (not shown).
4. Pull fastener back through access holes and hitch.
5. Remove pull wires and attach conical washers and nut (be careful not to push fastener back into frame rail).
6. Tighten to specification.

Tighten all 7/16-14 GR5 fasteners with torque wrench to 50 Lb.-Ft. (68 N*M)

Note: check hitch frequently, making sure all fasteners and ball are properly tightened. If hitch is removed, plug all holes in trunk pan or other body panels to prevent entry of water and exhaust fumes. A hitch or ball which has been damaged should be removed and replaced. Observe safety precautions when working beneath a vehicle and wear eye protection. Do not cut access or attachment holes with a torch.