

Installation Instructions

Mitsubishi Outlander Sport / RVR

Part Numbers:
36509
90210
06131

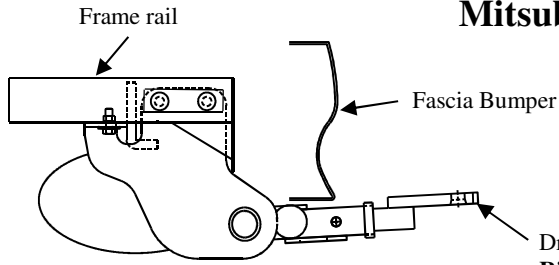

Drawbar Kit:
36051
 Drawbar must be used in the **Rise** position only.

Do Not Exceed Lower of Towing Vehicle Manufacturer's Rating or

3500 Lb. (1589 kg) Max Gross Trailer Weight
300 Lb. (136 kg) Max Tongue Weight

Wiring Access Location: SUV 1, SUV 2

Hitch Shown In Proper Position

Fastener Kit: 36509F

Equipment Required: N/A

Wrenches: 14mm, 17mm, 3/4 or 7/8

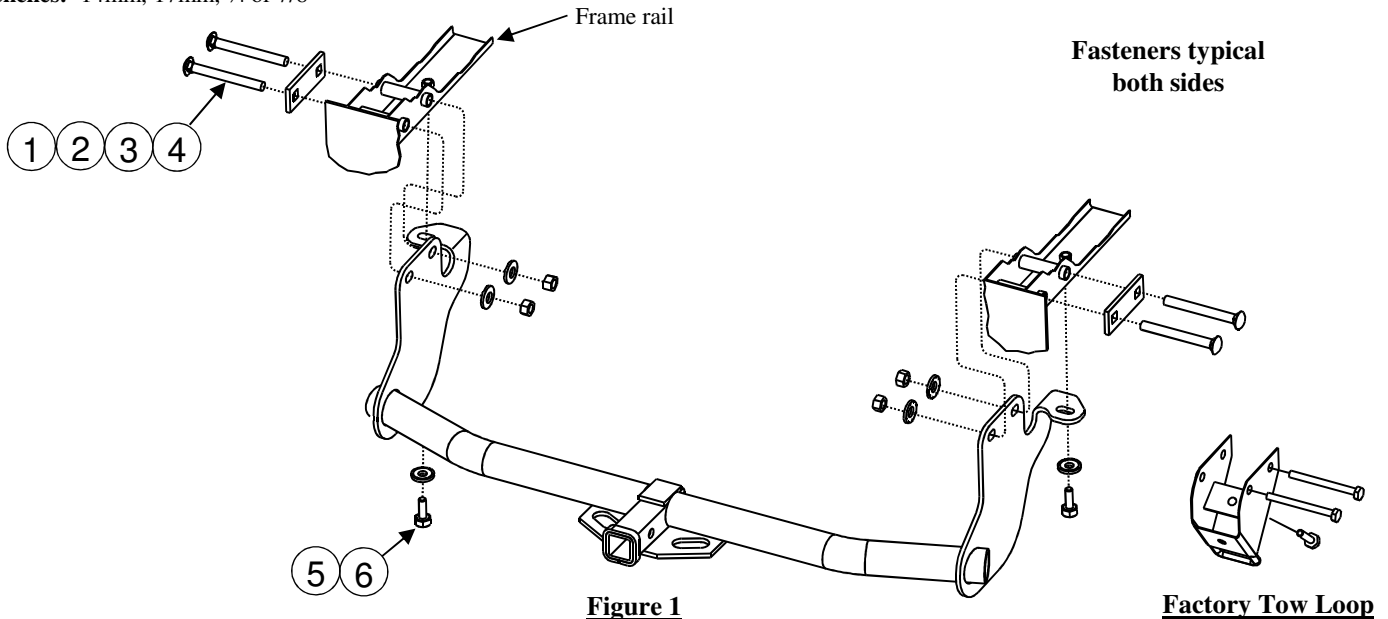

Figure 1

Factory Tow Loop

①	Qty. (2)	Block .250 x 1.50 x 4.00 (2 square holes)	⑤	Qty. (2)	Bolt M10 x 1.25 x 30mm CL8.8
②	Qty. (4)	Carriage bolt 1/2-13 x 4.50 Long Gr5	⑥	Qty. (2)	7/16 Conical Washer
③	Qty. (4)	1/2 Conical washer			
④	Qty. (4)	Hex nut 1/2-13			

- Remove (3) bolts and factory tow loop from passenger's side frame rail. Return bolts and tow loop to vehicle owner..
- Insert carriage bolts and blocks into existing holes in the side of frame rails. Adjust carriage bolts to be flush with inside of frame rails.
 Note: On the driver's side, the carriage bolts are installed by reaching between the bumper fascia and over the top the carbon canister.
- Raise the hitch into position and push the carriage bolts through the holes in hitch. Loosely install the 1/2 conical washers and hex nuts onto carriage bolts.
 Tip: For ease of installation, raise the driver's side of hitch first, guiding the flange on side bracket around the carbon canister. Then raise the passenger's side into position.
- Loosely install the M10 hex bolts with 7/16 conical washers into existing weld nuts in the bottom of frame rails.
- First, tighten the 1/2-13 GR5 carriage bolts to specifications.
- Then, tighten the M10 CL8.8 bolts to specifications.

Cequent



Tighten all 1/2-13 GR5 fasteners with torque wrench to 75 Lb.-Ft. (102 N*M)

Tighten all M10-1.25 CL8.8 fasteners with torque wrench to 42 Lb.-Ft. (57 N*M)