

Installation Instructions

Part Numbers:

Subaru Legacy and OutBack
All models

36493

06669

90208

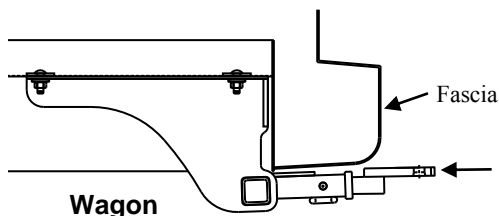

Drawbar Kit-Wagon

36051

Supplied with hitch

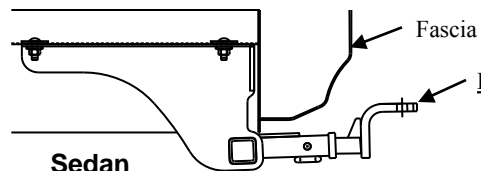

Drawbar Kit - Sedan

36071

Sold separately

**Do Not Exceed Lower of Towing Vehicle
Manufacturer's Rating or**

Hitch type	Max Gross Trailer WT (LB)	Max Tongue WT (LB)
Weight Carrying Ball Mount	3500 (1589 Kg.)	300 (136 Kg.)

Hitch Shown In Proper Position

Equipment Required: Tin snips, Spray lubricant

Fastener Kit: 36493F

Wrenches: 10mm, 11/16"

Drill Bits: 1-1/8" Hole Saw

Drawbar must be used in the Rise position only.

Wiring Access Location: PC3

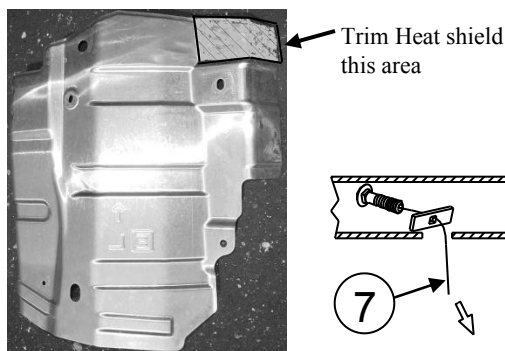

Figure 2.

Figure 3.

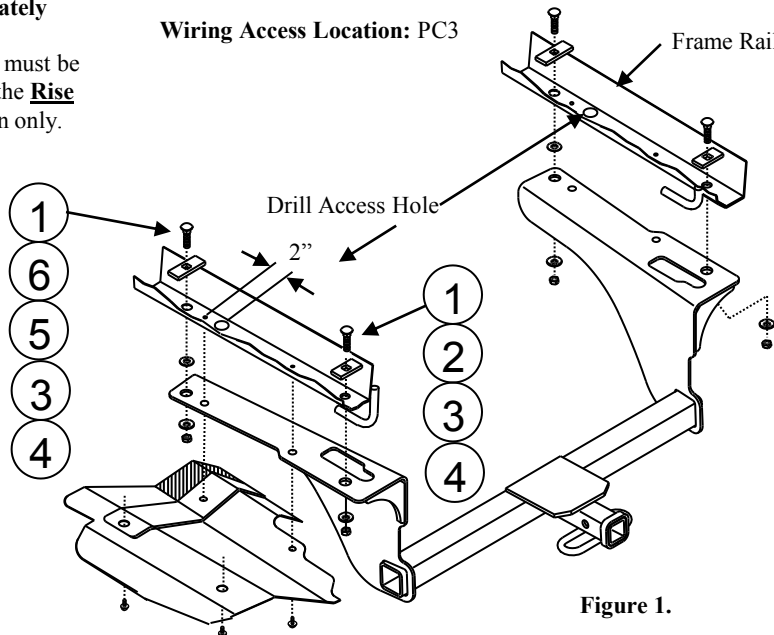

Figure 1.

①	Qty. (4)	Carriage Bolt 7/16-14 x 1.50 GR5	⑤	Qty. (2)	Flat washer, 7/16
②	Qty. (2)	Spacer 3/16" x 1 x 2	⑥	Qty. (2)	Spacer 1/4" x 1 x 3
③	Qty. (4)	Conical Toothed Washer 7/16"	⑦	Qty. (4)	Fish wire, 7/16
④	Qty. (4)	Hex Nut 7/16-14			

- Temporarily lower exhaust system by removing the two rubber isolators from muffler hangers and one below rear axle.
Notes: Spray hangers for ease of removal. Typical both sides for models with dual exhaust system.
- Temporarily lower heat shields by removing four (4) M6 bolts. Save bolts to re-install heat shields.
- Remove rubber plugs from holes in bottom of frame.
- Drill a 1-1/8" access hole in bottom of frame approximately 2" from forward heat shield attachment, see figure 1.
- Fish-wire carriage bolt and 1 x 2 block through access hole and down through rearmost hole in bottom of frame.
- Fish-wire carriage bolt and 1 x 3 block through access hole down through forward hole in bottom of frame.
Note: Leave fish-wires attached to bolts and feed end of wires through holes in hitch.
- Raise hitch into position aligning the holes in the hitch over the carriage bolts. Be careful not to push bolts back up into frame.
- Loosely install the conical toothed washers & hex nuts onto rearmost carriage bolts.
- Place flat washer (item 5) on forward carriage bolt between frame and hitch bracket.
- Install the conical toothed washers & hex nuts onto forward carriage bolts. Tighten fasteners to specifications below.
- Trim heat shields around area near forward attachment bolt so that the heat shield sits flat against the hitch bracket.
- Re-attach heat shields on top of hitch brackets using the four (4) M6 bolts.
- Raise exhaust system back into position, re-attaching rubber isolators including under axle.

Tighten all 7/16 GR5 fasteners with torque wrench to 50 Lb.-Ft. (68 N*M)