

Installation Instructions

**Acura CSX
Acura ILX**

Part Numbers:
**24861
60277
77247
24888 U-Haul**

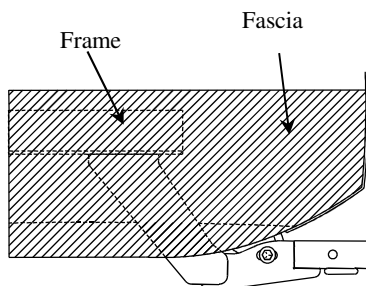

Drawbar Kit:
3593

**Do Not Exceed Lower of Towing Vehicle
Manufacturer's Rating or**

2000 LB (908 Kg) Max Gross Trailer Weight

200 LB (90.8 Kg) Max Tongue Weight

Accessory Rating

A

Hitch Shown In Proper Position

Equipment Required: Small screwdriver, Tape,
Utility Knife, Tape Measure & Marking Pencil.

Fastener Kit: 24861F

Wrenches: 3/4, 7/8, 10mm

Wiring Access Location: CSX- PC3, PC4
ILX-PC1, PC2

Note! Torque is different for bolts in to frame than bolt through tow hook. See torque spec below.

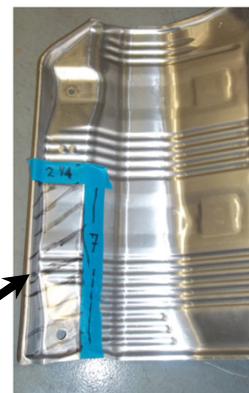
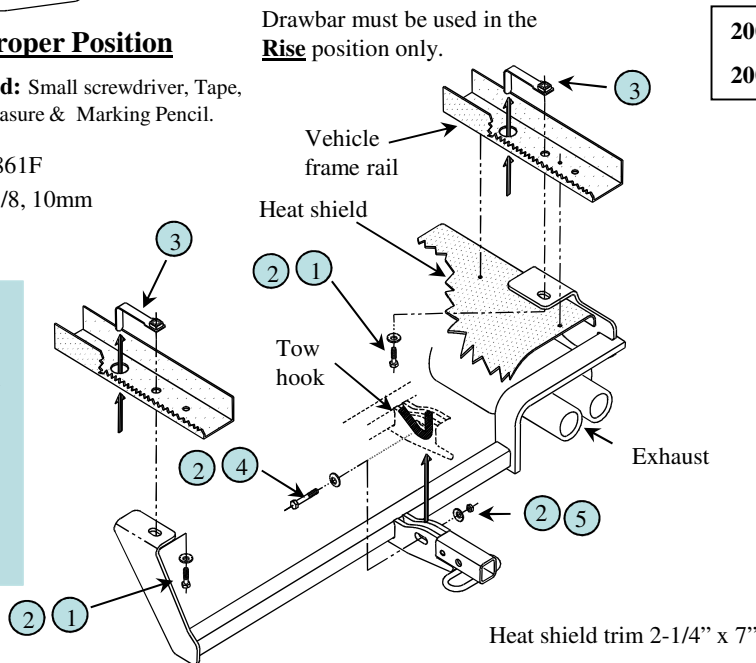

①	Qty. (2)	1/2"-13 x 1-1/4" Hex Bolt Gr.5 , (Torque to 50 Ft. Lb.)	④	Qty. (1)	1/2-13 x 2-1/4" Hex Bolt Gr.5, (Torque to 75 Ft. Lb.)
②	Qty. (4)	1/2" Conical Toothed Washer	⑤	Qty. (1)	1/2-13 Lock Nut
③	Qty. (2)	1/2"-13 Handle Nut			Another Fine Cequent Performance Products Hitch

Note: instructions for Acura CSX

1. Lower vehicle exhaust by removing tailpipe tangs out of rubber exhaust hanger at rear of vehicle.
2. On the Passenger's side remove the (4) bolts that attach the exhaust heat shield to the vehicle. (Do not Discard).
3. On the Driver's side, remove the plastic rivet and nut that hold the plastic shroud to the frame rail. (Do not Discard).
4. Raise hitch into position with frame bracket flanges between the frame rail and plastic shroud on the Driver's side and between the frame rail and exhaust heat shield on the Passenger's side. Make sure that tailpipe tangs are above hitch bar while raising hitch in to place. On some vehicles it may be necessary to remove chrome decorative ring off of end of tailpipe to allow muffler to slide sideways toward middle of vehicle to allow better wrench access.
5. Insert 1/2"-13 handle nuts through the large holes in vehicle frame rails and install fasteners as shown above.
6. Insert the 1/2-13 x 2-1/4" bolt and toothed washer through the slot in the hitch then through the vehicle tow hook and back through the hitch. Install toothed washer on other side then locknut. (see above).
7. Pull hitch rearward as far as possible to allow muffler clearance with hitch bar on passenger's side. Tighten all fasteners to the required torque specifications shown below.
8. Reinstall exhaust heat shield over hitch. Heat shield may require trimming. Reattach exhaust to hanger & replace rivet and nut holding plastic shroud on driver's side. Reattach chrome decorative ring to tailpipe if removed.

Note: instructions for Acura ILX – Do Not lower exhaust – 2 persons install.

1. Remove appearance panel. Remove multiple fasteners (4) plastic rivets and (3) bolts. To remove the plastic rivets remove the center of the rivet with a screwdriver. Remove the appearance panel and return it to the owner. Reinstall all fasteners removed.
2. Remove heat shield (4) bolts and trim as shown. (Do not discard).
3. Insert 1/2-13 handle nuts through the large holes in both vehicle frame rails bending the handle as shown.
4. Raise hitch into position, starting on the passenger side slide the bar on the hitch over the exhaust tail pipe pulling downward on the exhaust for additional clearance, being careful not to scratch the fascia. Slide the hitch into position on the passenger's side and install the 1/2-13 X 1-1/4" bolt and conical washer.
5. Rotate the hitch into position on the tow hook and insert the 1/2-13 x 2-1/4" bolt and toothed washer through the slot in the hitch then through the vehicle tow hook and back through the hitch. Install toothed washer on other side then locknut. (See above).
6. Install remaining hardware on the drivers side. Pull hitch rearward as far as possible to allow muffler clearance with hitch bar on passenger's side. **Tighten all fasteners to the required torque specifications shown below.**
7. Reinstall the trimmed heat shield over exhaust.

Tighten 1/2"-13 x 1-1/4" Hex Bolts with torque wrench to 50 Lb.-Ft. (68 N*M) Tighten 1/2"-13 x 2-1/4" Hex Bolt to 75Lb.-Ft. (102 N*M)

Cequent

