

Installation Instructions

Hyundai Santa Fe GLS/Limited (6/7 Passenger)

Part Numbers:

75776

44691

87637

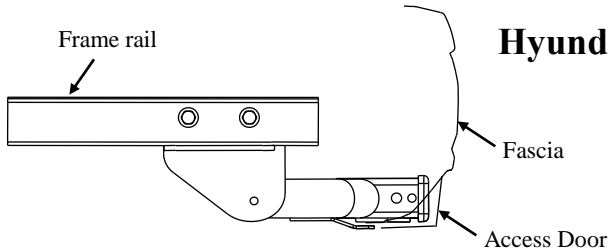

**Do Not Exceed Lower of Towing Vehicle
Manufacturer's Rating or**

| Hitch type | Max Gross Trailer WT (LB) | Max Tongue WT (LB) |
|----------------------------|---------------------------|--------------------|
| Weight Distributing | 7000 Lb (3401 Kg) | 750 Lb (340 Kg) |
| Weight Carrying Ball Mount | 5000 Lb (2267 Kg) | 750 Lb (340 Kg) |

Hitch Shown In Proper Position

Equipment Required: #2 Phillips Screwdriver

Fastener Kit: 75776F

Wrenches: 17mm, 19mm

Drill Bits: None

Wiring Access Location: SUV1, SUV2

Accessory Rating

C

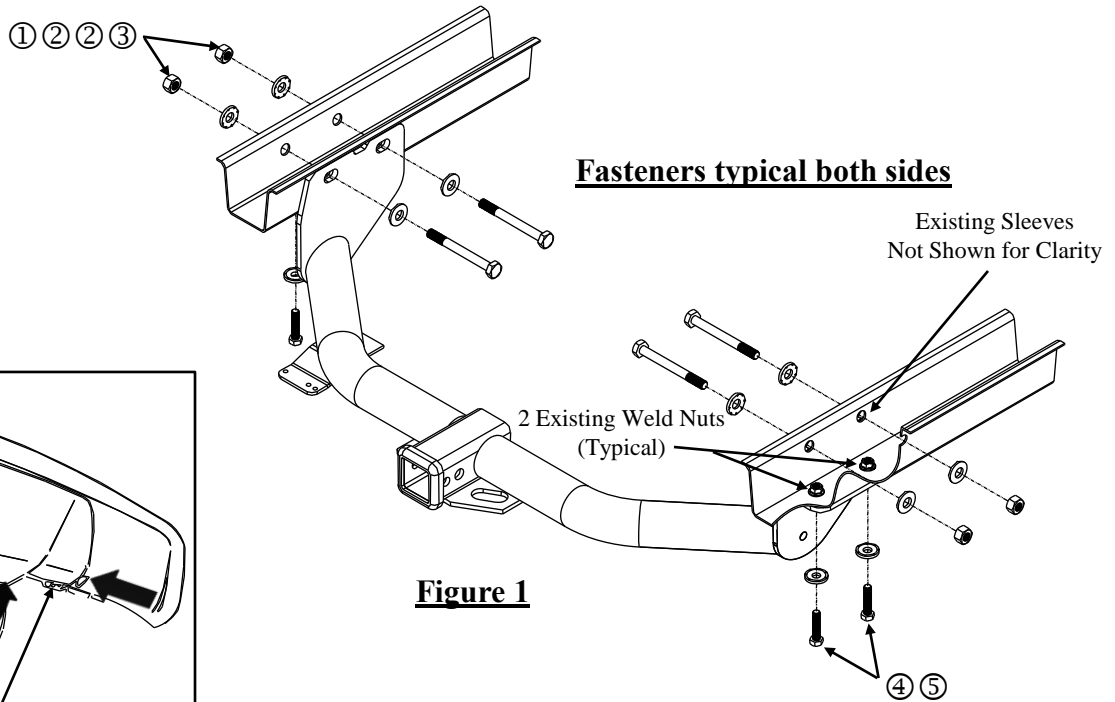
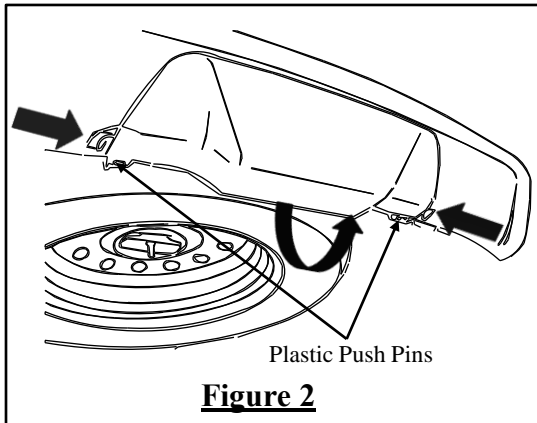

Figure 1



Plastic Push Pins

Figure 2

| | | | | | |
|---|----------|-----------------------------|---|----------|-----------------------------|
| ① | Qty. (4) | M12 x 1.75 x 120 Bolt CL8.8 | ④ | Qty. (4) | M10 x 1.25 x 30 Bolt CL10.9 |
| ② | Qty. (8) | 1/2" Conical Washer | ⑤ | Qty. (4) | 7/16" Conical Washer |
| ③ | Qty. (4) | M12 x 1.75 Nut CL10 | | | |

1. Lower and remove spare tire from vehicle. The tire release is located underneath the storage compartment in the back of the vehicle.
2. Remove the access door on rear fascia by removing the two plastic push pins with a #2 phillips screwdriver and pushing the two outside tabs inward. (Figure 2)
3. Raise hitch into position and insert M12 bolts through the bracket and frame as shown in Figure 1. Note: The plastic bumper locator pin may interfere with the hitch hardware. If necessary, trim the locator pin at the shoulder to allow proper hardware clearance.
4. Insert M10 bolts through bracket and into the frame as shown in Figure 1 (Hand tighten).
5. Torque M10 bolts first and then M12 bolts to the specifications below.
6. Reinstall spare tire and make sure it is seated properly.
7. Reinstall access door removed in Step 2

Tighten all M10 CL10.9 fasteners with torque wrench to 40 Lb.-Ft. (54 N*M) Tighten all M12 CL8.8 fasteners with torque wrench to 72 Lb.-Ft. (98 N*M)

Note: check hitch frequently, making sure all fasteners and ball are properly tightened. If hitch is removed, plug all holes in trunk pan or other body panels to prevent entry of water and exhaust fumes. A hitch or ball which has been damaged should be removed and replaced. Observe safety precautions when working beneath a vehicle and wear eye protection. Do not cut access or attachment holes with a torch.