

# Installation Instructions

## Ford F-150

Part Numbers:

**75691**

**87583**

**44645**

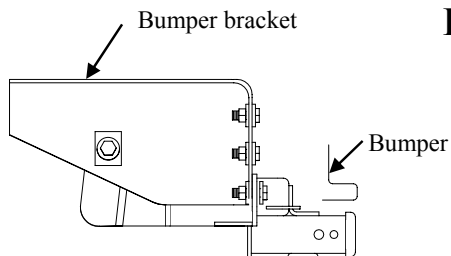

**Do Not Exceed Lower of Towing Vehicle  
Manufacturer's Rating or**

Hitch type	Max Gross Trailer WT (LB)	Max Tongue WT (LB)
Weight Distributing	<b>12,000 (5448 Kg)</b>	<b>1200 (545 Kg)</b>
Weight Carrying Ball Mount	<b>6000 (2724 Kg)</b>	<b>600 (272 Kg)</b>

### Hitch Shown In Proper Position

#### Equipment Required:

**Fastener Kit:** 75691F

**Wrenches:** Open end 3/4 wrench & 7/8"

**Wiring Access Location: PC3**

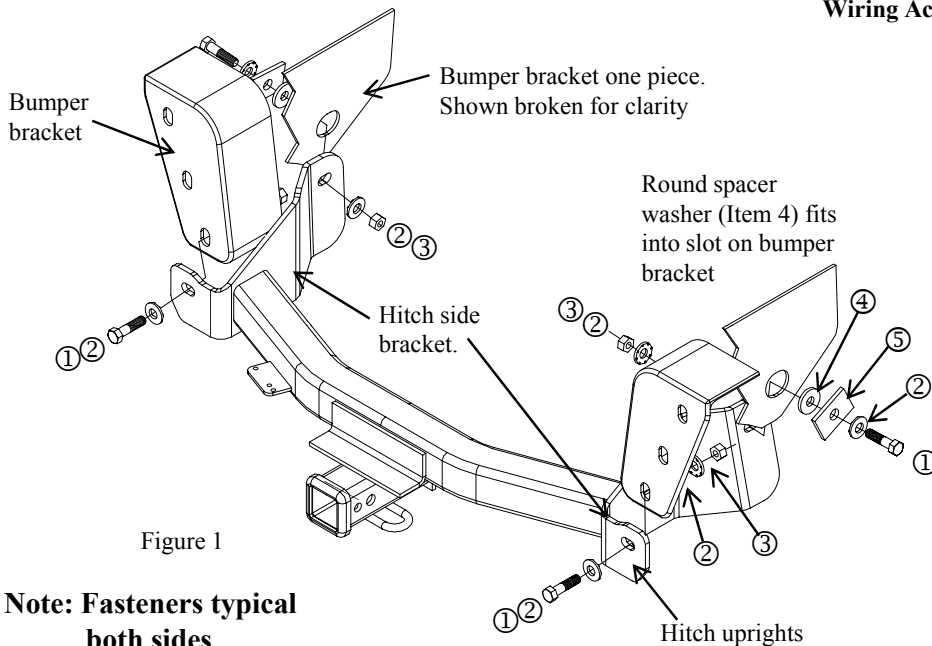

Figure 1

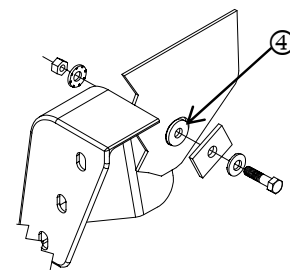

Figure 2

Item 4 must be sandwiched inside slot on bumper bracket.

**Note: Fasteners typical both sides**

①	Qty. (4)	Hex bolt, 1/2-13 X 2.0 Gr5	④	Qty. (2)	Spacer round
②	Qty. (8)	Conical washer	⑤	Qty. (2)	Spacer 1/4" X 2.50 X 1.75
③	Qty. (4)	Hex nut, 1/2-13			

Removal of the spare tire can make installation easier, however, removal not necessary.

1. Raise hitch into position as shown in Figure 1. Use fasteners to attach the hitch uprights to the bumper bracket.
2. Attached remaining fasteners as shown. Item 4 must be sandwiched inside slot on bumper bracket. The hitch brackets and the vehicle bracket will be drawn together.
3. Torque all fasteners to specifications shown below.
4. Reinstall spare tire, if it was removed prior to hitch installation. Make sure spare tire does not contact bolts.

**Tighten all 1/2 GR5 fasteners with torque wrench to 75 Lb.-Ft (102 N-m).**

Note: check hitch frequently, making sure all fasteners and ball are properly tightened. If hitch is removed, plug all holes in trunk pan or other body panels to prevent entry of water and exhaust fumes. A hitch or ball which has been damaged should be removed and replaced. Observe safety precautions when working beneath a vehicle and wear eye protection. Do not cut access or attachment holes with a torch.