

# Installation Instructions

Part Numbers:

## Volvo XC60

75671

87566

44629

Do Not Exceed Lower of Towing Vehicle  
Manufacturer's Rating or

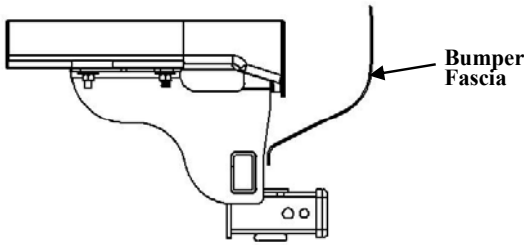

### Hitch Shown In Proper Position

Equipment Required: USE ONLY 8.5" LONG X  
3/4" RISE X 2" DROP BALL MOUNT

Fastener Kit: 75671F

Wrenches: 13mm, 11/16"

Drill Bits: none

Fishwire - provided

Tin snips

Foam tape  
over holes

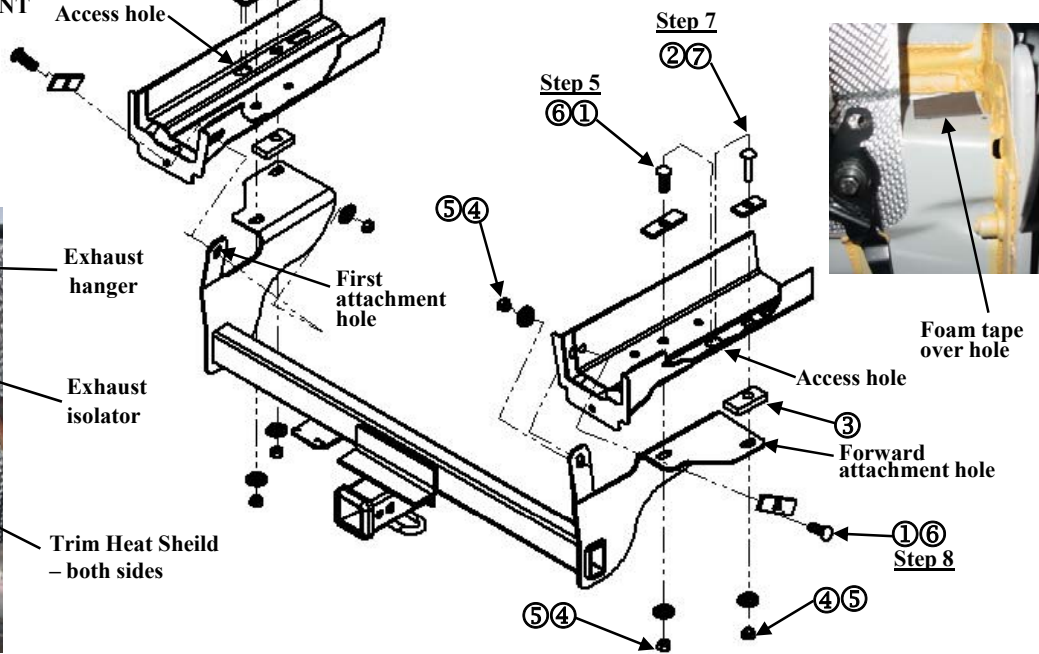

Wiring Access Location: SUV 3,4

Hitch type	Max Gross Trailer WT (LB)	Max Tongue WT (LB)
Weight Distributing	4,500 (2043 kg)	450 (204 kg)
Weight Carrying Ball Mount	4,000 (1816 kg)	400 (181 Kg)

①	Qty. (4)	Bolt – carriage 7/16" – 14 x 1-1/2" gr 5	⑤	Qty. (6)	Nut – 7/16" - 14
②	Qty. (2)	Bolt – carriage 7/16" – 14 x 2" gr 5	⑥	Qty. (4)	Block – 1/4" x 1" x 3"
③	Qty. (2)	Block – 1/2" x 1-1/4" x 2-1/2"	⑦	Qty. (2)	Block – 3/16" x 1" x 2"
④	Qty. (6)	Washer – 7/16" conical	⑧	Qty. (2)	Fish wire – 7/16"

1. Raise vehicle.
2. Lower exhaust by removing rubber isolator from muffler support. Temporarily remove exhaust hanger for ease of heat shield trimming and hitch installation.
3. Trim heat shield (both sides) with tin snips as shown above. **Caution**, edges are sharp.
4. Remove foam tape covering holes on the bottom and on the inside of the frame (shown above). Keep tape to cover unused holes.
5. Using the fish wire provided, install item 1 and 6 into location shown through access hole (both sides).
6. Gently lifting the rear fascia and slide hitch over exhaust into position. Raise hitch up to frame making sure not to push fasteners back into frame. Loosely install conical washers and nuts.
7. Slide block item 3 between the hitch and frame on the forward attachment. Fish wire item 2 and 7 through access hole and through forward attachment holes. Install conical washers and nuts as shown
8. Insert the coil end of fish wire through first attachment hole in hitch and into the frame. Angle the wire back so it comes out the end of the bumper. Insert item 1 and 6 into the first attachment hole and install conical washers and nuts.
9. Pull hitch rearward as much as possible and tighten fasteners.
10. Re-install the muffler hanger removed in step 2. Re-attach muffler to the rubber isolators. Cut foam tape and cover unused holes in frame

Tighten all 7/16" fasteners with torque wrench to 50 Lb.-Ft. (68 n-m)

Note: check hitch frequently, making sure all fasteners and ball are properly tightened. If hitch is removed, plug all holes in trunk pan or other body panels to prevent entry of water and exhaust fumes. A hitch or ball which has been damaged should be removed and replaced. Observe safety precautions when working beneath a vehicle and wear eye protection. Do not cut access or attachment holes with a torch.