

# Installation Instructions

03-08 Honda Element, all inc. \*SC model

\*SC requires plastic bumper fascia trimming.

Part Numbers:  
75659, 87506,  
44612

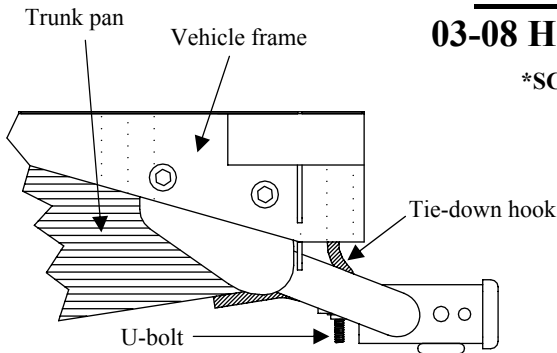

## Hitch Shown In Proper Position

### Equipment Required:

**Fastener Kit:** 75659F

**Wrenches:** 3/4", 7/8"

**Drill Bits:** None

Do Not Exceed Lower of Towing Vehicle Manufacturer's Rating or

Hitch type	Max Gross Trailer WT (LB)	Max Tongue WT (LB)
Weight Distributing	N/A	N/A
Weight Carrying Ball Mount	3500 (1589 Kg)	350 (159 Kg)

Wiring Access Location: 2003-04 SUV2 / 2005-Current SUV1-2

3/4" flat washers; ④, slide over end of tube spacer after inserting into frame, between inside of vehicle frame and outside of hitch bracket.

This side shows how to install bolts, flat washers & tube spacers before raising hitch into place. Typical both sides.

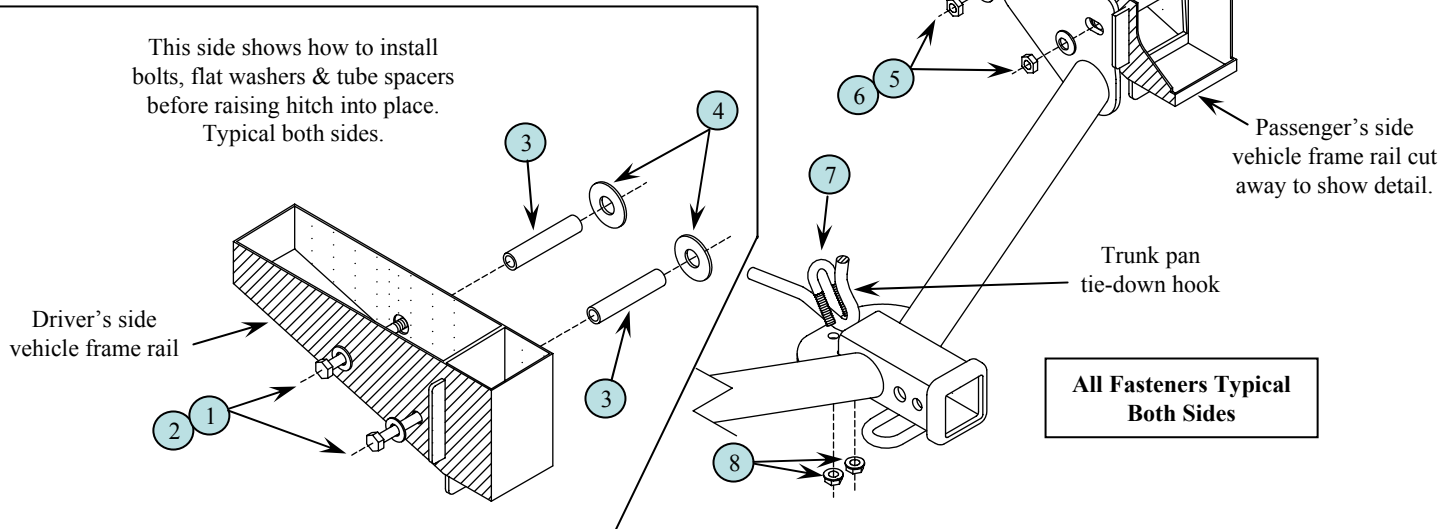

①	Qty. (4)	1/2"-13 X 5-1/2" Gr. 5 Hex Bolt	⑤	Qty. (4)	1/2" Conical Toothed Washer
②	Qty. (4)	1/2" Flat Washer	⑥	Qty. (4)	1/2" Hex Nut
③	Qty. (4)	Tube Spacer	⑦	Qty. (1)	3/8" U-Bolt
④	Qty. (4)	3/4" Flat Washer	⑧	Qty. (2)	3/8" Flanged Hex Locknut

1. Install 1/2" bolts and 1/2" flat washers from outside of vehicle frame as shown above. Install tube spacers and 3/4" flat washers from inside of frame as shown above. Pull bolts back so that they barely stick through. Do this both sides of vehicle.
2. Raise hitch into position carefully without knocking washers down that were installed in Step 1. As an alternative you can slide 3/4" flat washers into place after raising hitch. They go over tube spacers between vehicle frame and hitch brackets.
3. Carefully push 1/2" bolts through hitch brackets on both sides making sure that 3/4" flat washers are over tube spacers and between inside of vehicle frame and outside of hitch frame bracket. Install conical washers and hex nuts. Loosely tighten.
4. Install 3/8" u-bolt over vehicle trunk pan tie-down hook and down through center hitch bracket. See diagram above.
5. Install 3/8" flanged hex locknuts on u-bolt so that it draws up evenly. Tighten u-bolt first. Then tighten (4) 1/2" bolts.

Tighten 1/2" bolts with torque wrench to 75 Lb.-Ft. (102 N\*M) Tighten 3/8" u-bolt with torque wrench to 30 Lb.-Ft. (41 N\*M)

Note: check hitch frequently, making sure all fasteners and ball are properly tightened. If hitch is removed, plug all holes in trunk pan or other body panels to prevent entry of water and exhaust fumes. A hitch or ball which has been damaged should be removed and replaced. Observe safety precautions when working beneath a vehicle and wear eye protection. Do not cut access or attachment holes with a torch.