

Installation Instructions

Part Numbers:

BMW X5

75600

87455

44590

Note: Fascia trim required

Do Not Exceed Lower of Towing Vehicle
Manufacturer's Rating or

Hitch type	Max Gross Trailer WT (LB)	Max Tongue WT (LB)
Weight Distributing	6000 (2724 Kg)	600 (272 Kg)
Weight Carrying Ball Mount	6000 (2724 Kg)	600 (272 Kg)

Hitch Shown In Proper Position

Equipment Required: Utility Knife, Small center punch, 5/32" Rivet tool

Fastener Kit: 75600F

Wrenches: 10mm, 18mm Deep Socket

Wiring Access Location: SUV3 & SUV4

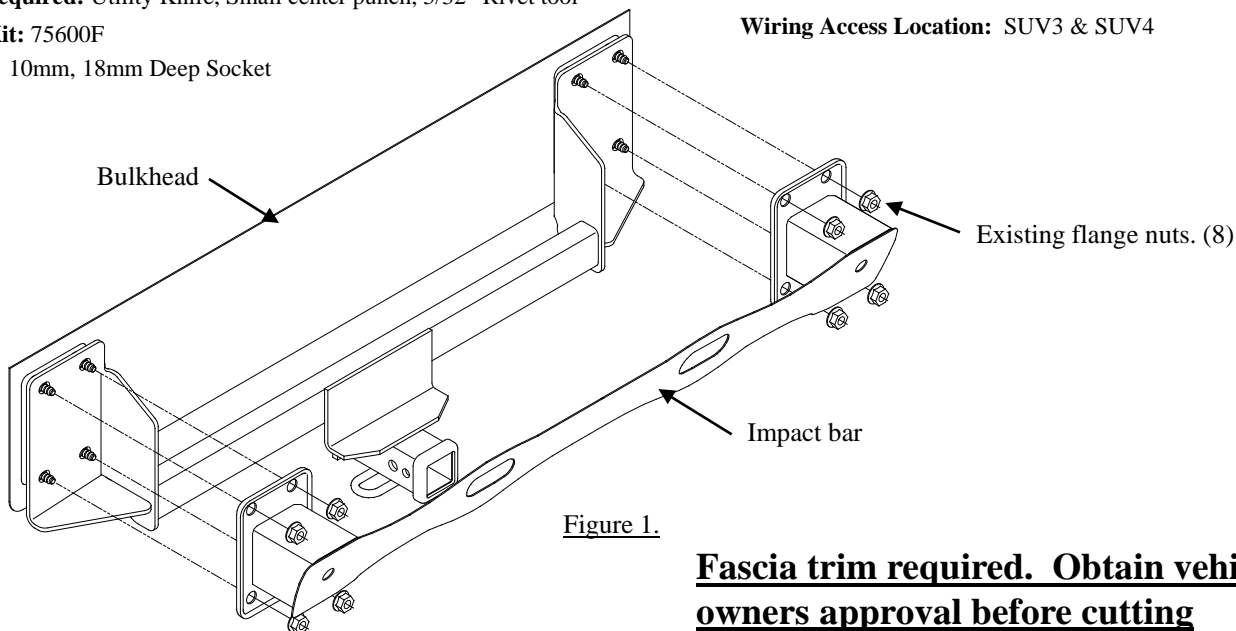

Figure 1.

Fascia trim required. Obtain vehicle owners approval before cutting

①	Qty. (4)	Plastic rivet (Not shown)
---	----------	---------------------------

1. Remove rear bumper fascia. Disconnect back-up sensor wiring if present. (Not shown)
 - a. Remove 2 plastic pop rivets (each side) from the plastic wheel well molding (See Figure 2). Rivets can not be re-used. Replacements supplied. To remove rivet, insert small center punch or drill bit into center to push pin through.
 - b. Gently pull back wheel well molding to locate and remove fascia screws (See Figure 4). One each side.
 - c. Remove 6 screws from bottom of fascia.
 - d. Remove reflectors, (Reflector can be removed by releasing the clip that holds it in place, access under the bumper) (Figure 2).
 - e. Remove the screws behind the reflectors (See Figure 3).
 - f. Gently pull the fascia from the wheel wells outwards and rearward from the rear of the vehicle.
2. Remove impact bar using 18mm deep socket. Lower tailgate to access upper mounting fasteners.
3. Raise hitch into position.
4. Re-install impact bar over hitch brackets, and re-install existing flange nuts (See Figure 1). Center hitch on vehicle.
5. Tighten all fasteners to torque specifications. Tighten all M12 fasteners with torque wrench to 65 Lb.-Ft. (88 N*M)
6. Trim fascia using utility knife. Locate bottom center of the fascia mark 4" wide side to side x 2" high. (overall 8" wide X 2" high) (See Figure 5). Fascia trim required. Obtain vehicle owners approval before cutting
7. Reattach bumper fascia. Reconnect wiring. (Not shown)

Tighten all M12 fasteners with torque wrench to 65 Lb.-Ft. (88 N*M)

Note: check hitch frequently, making sure all fasteners and ball are properly tightened. If hitch is removed, plug all holes in trunk pan or other body panels to prevent entry of water and exhaust fumes. A hitch or ball which has been damaged should be removed and replaced. Observe safety precautions when working beneath a vehicle and wear eye protection. Do not cut access or attachment holes with a torch.

Installation Instructions

BMW X5

Note: Fascia trim required

Part Numbers:

75600

87455

44590

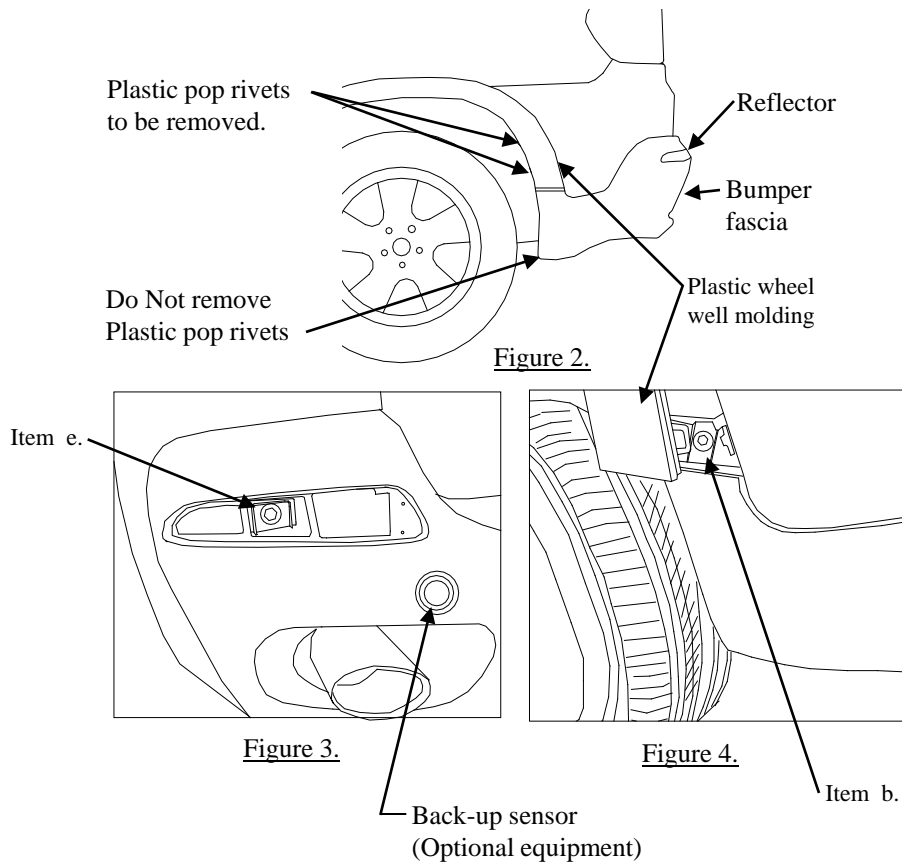

Fascia trim required.
Obtain vehicle owners
approval before cutting

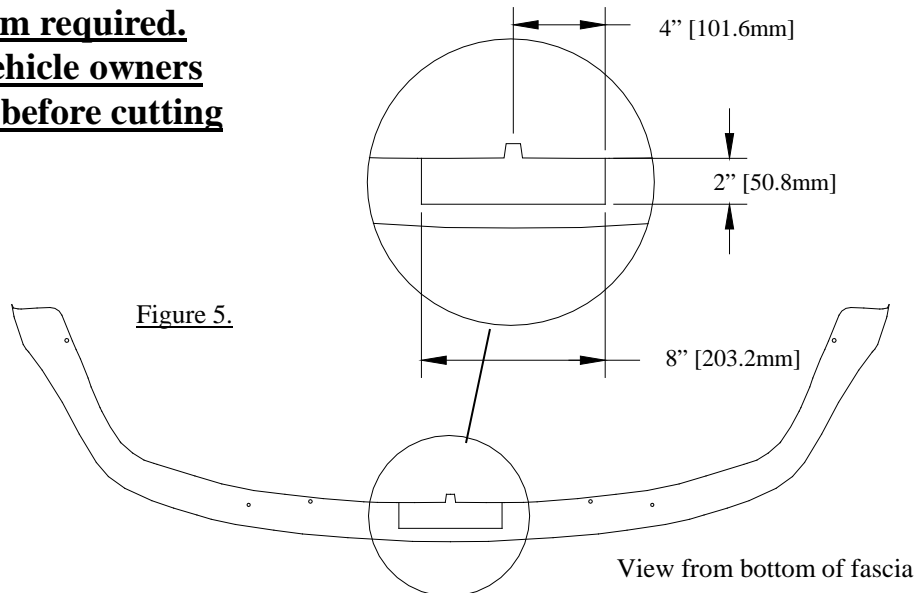

Note: check hitch frequently, making sure all fasteners and ball are properly tightened. If hitch is removed, plug all holes in trunk pan or other body panels to prevent entry of water and exhaust fumes. A hitch or ball which has been damaged should be removed and replaced. Observe safety precautions when working beneath a vehicle and wear eye protection. Do not cut access or attachment holes with a torch.