

Installation Instructions

Pontiac Aztek- All Models

Buick Rendezvous – All Models

Part Numbers:

75430

44538

87004

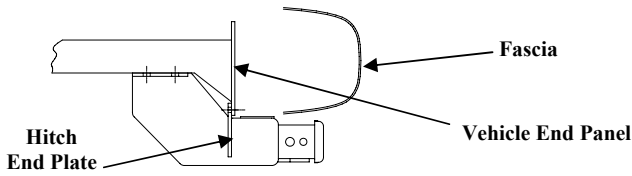

Figure 2

Hitch Shown In Proper Position

**Do Not Exceed Lower of Towing Vehicle
Manufacturer's Rating or**

3500 LB Max Gross Trailer Weight

350 LB Max Tongue Weight

Equipment Required:

Fastener Kit: 75430F or 87004F

Wrenches: 9/16, 11/16, 3/4

Drill Bits: 3/8"

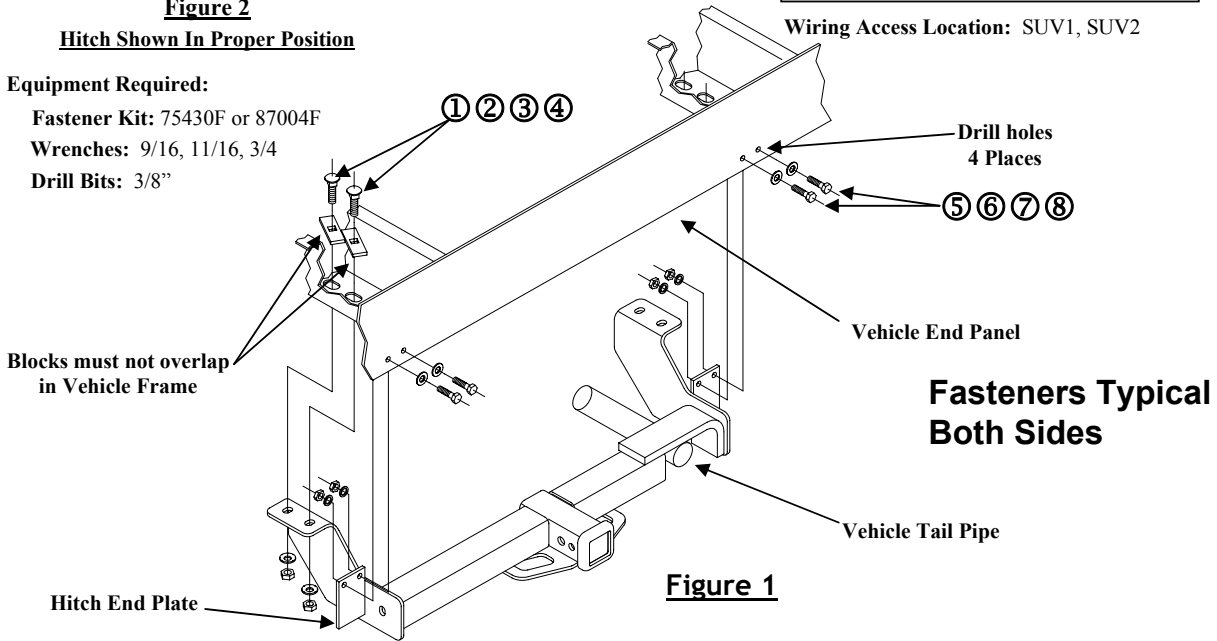

Figure 1

**Blocks must not overlap
in Vehicle Frame**

**Fasteners Typical
Both Sides**

①	Qty. (4)	Carriage Bolt - 1/2-13 x 1-3/4	⑤	Qty. (4)	Hex Bolt – 3/8-16 x 1-1/4
②	Qty. (4)	Block 1/4 x 1 x 3	⑥	Qty. (4)	Flat washer – 3/8
③	Qty. (4)	Conical Toothed Washer – 1/2	⑦	Qty. (4)	Lock Washer – 3/8
④	Qty. (4)	Nut 1/2-13	⑧	Qty. (4)	Nut 3/8-16

NOTE: Lowering exhaust may ease installation. To lower exhaust, remove rubber hanger from hanger bracket.

1. Install block and carriage bolt up thru rearmost slot in vehicle frame rail and down thru forward slot in frame, each side.
2. Install block and carriage bolt up thru rearmost slot in vehicle frame rail and back down thru same rearmost slot, each side.

NOTE: Be sure block installed in steps 1 and 2 do not overlap inside frame.

3. Raise hitch into position on carriage bolts, making sure rear face of hitch end plate contacts lip of vehicle end panel as shown in figure 2. Install conical toothed washers and nuts, finger tight.
4. Using 3/8" drill bit, drill thru holes in hitch end plate into lip of vehicle end panel, two places each side.
5. Install 3/8" hex bolts, flat washers, lock washers and nuts as shown. Tighten 3/8-16 fasteners with torque wrench to 30 lb.-ft.
6. Raise exhaust back into position if lowered prior to hitch installation.

NOTE: If additional exhaust clearance is required, bend exhaust hanger bracket, which is welded to vehicle frame, downward.

Tighten all 1/2-13 fasteners with torque wrench to 75 Lb.-Ft.

Tighten all 3/8-16 fasteners with torque wrench to 30 Lb.-Ft.

Note: check hitch frequently, making sure all fasteners and ball are properly tightened. If hitch is removed, plug all holes in trunk pan or other body panels to prevent entry of water and exhaust fumes. A hitch or ball which has been damaged should be removed and replaced. Observe safety precautions when working beneath a vehicle and wear eye protection. Do not cut access or attachment holes with a torch.